

Health Effects of Electromagnetism

McGill Course OCCH-605

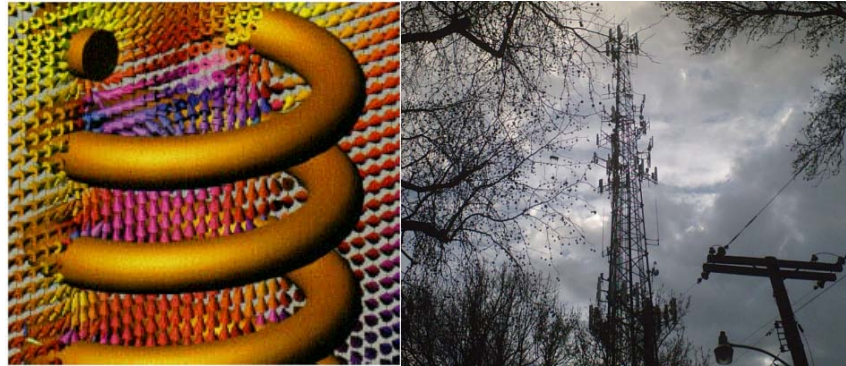

Paul Héroux, PhD

Faculty of Medicine

McGill University

January 2023

paul.heroux@mcgill.ca

©2023 Paul Héroux

This text can be freely copied, distributed and used for formal and informal educational purposes.

invitroplusnet.wordpress.com

Health Effects of Electromagnetism

1. Electric Power Systems

2. Electrical Safety

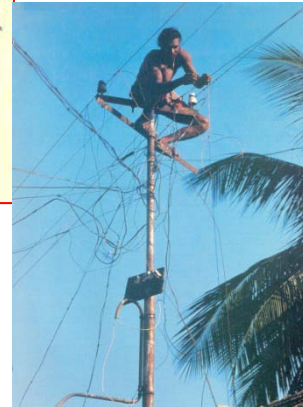
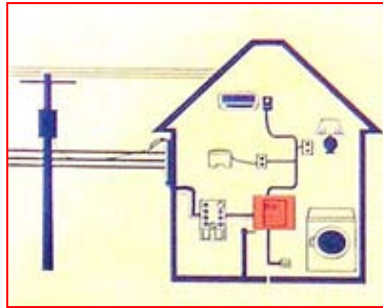

3. Electromagnetism and Biology

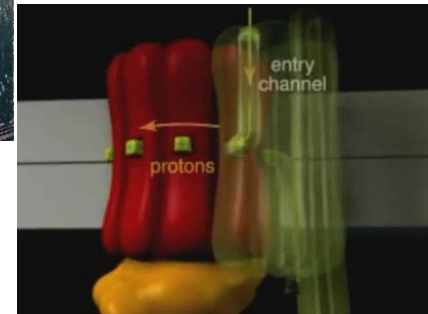

4. Health Effects of Extra-Low-Frequency Radiation

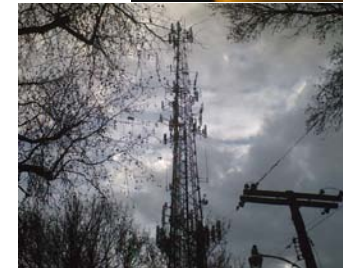

5. Health Effects of Radio-Frequencies and MicroWaves



International Units Prefixes		
Factor	Name	Symbol
10^{24}	yotta	Y
10^{21}	zetta	Z
10^{18}	exa	E
10^{15}	peta	P
10^{12}	tera	T
10^9	giga	G
10^6	mega	M
10^3	kilo	k
10^2	hecto	h
10^1	deka	da
10^{-1}	deci	d
10^{-2}	centi	c
10^{-3}	milli	m
10^{-6}	micro	μ
10^{-9}	nano	n
10^{-12}	pico	p
10^{-15}	femto	f
10^{-18}	atto	a
10^{-21}	zepto	z
10^{-24}	yocto	y

1. ELECTRIC POWER SYSTEMS.....	1
1.1. History of Electricity	1
1.2. Basics of Electricity.....	1
1.2.1. Electric Voltage, Current, Energy, Power	1
1.2.2. Ohm's Law	4
1.2.3. Kirchhoff's Rules	5
1.2.4. Power Equation	7
1.2.5. AC Circuits.....	7
1.2.6. Impedance	7
1.2.7. Inductance	9
1.2.8. Capacitance	11
1.2.9. Practical Measurements.....	14
1.3. Description of Electric Power Networks.....	15
1.3.1. Generation	15
1.3.2. Transmission	15
1.3.3. Distribution.....	16
1.3.4. Electrical Power demand over Time.....	17
1.3.5. Grounding as a Problem	18
1.3.6. Domestic.....	20
1.3.7. Power Metering and Smart Meters	22
1.3.8. Reactive Power.....	23
1.3.9. Dirty Electricity.....	24
1.3.10. Power Filtering.....	25
1.3.11. Power over Internet (PoE).....	25
1.3.12. Telephone Network	25
1.3.13. Industrial.....	25
1.3.13.1. Switches.....	25
1.3.13.2. Circuit Breakers	26
1.3.13.3. Fuses	26
1.3.14. Why 60 Hz?.....	27
1.3.15. Why 3-phase systems?	28
1.3.16. Why not DC systems?	29
1.4. Summary	30
1.5. Bibliography.....	30

1. ELECTRIC POWER SYSTEMS

1.1. History of Electricity

The ancient Greeks knew how to gather electricity by rubbing fur on amber. In 1750, Pieter van Musschenbroek discovered how to store it in a capacitor. In the 1880s, Thomas Edison transmitted direct current, and Nikola Tesla, alternating current. With reliable electricity for street lights, and as generators, substations, transformers and power lines were deployed, manufacturers could then build factories.

After World War II, most Western homes got a telephone, and electric inventions multiplied as refrigerators, washing machines and dryers, water heaters, sewing machines, vacuum cleaners, air conditioners and microwave ovens.

For communications, the telegraph was followed by wireless radio, television, military radar and cellular phones.

Since the beginning of the 20th century, many of us have included electricity on a list of basic needs.

We expect electricity and the Internet 24/7.

Few people considered the environmental consequences of electricity beyond acute safety, which is the subject of this and the following Chapter.

1.2. Basics of Electricity

Electricity is the most flexible form of energy¹. Consider atoms, made of a positively charged nucleus surrounded by a cloud of negative electrons. As long as the charge of the nucleus is balanced by an equal number of electrons, the atom is neutral. If an electron is extracted from the atom, it leaves behind a positive charge. Conversely, an atom can host an extra

¹ Galvani, the eighteenth century Italian physicist, held that it was the “vital force”, the element essential to life, for which philosophers had searched for centuries.

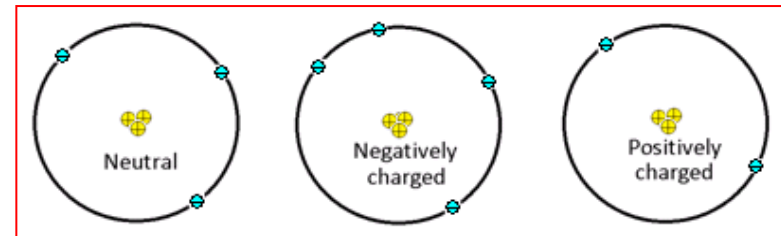

electron and become negatively charged. The motion of electrons in matter can therefore give it positive or negative polarity.

In conductive materials (metals, for example), electrons move about freely. The metal atoms form a container within which electrons diffuse as a cloud of charges, very similar to a gas (physicists call the electrons in a metal a *degenerate Fermi gas*). Electric fields apply force to the mobile electrons, which move through the metal very easily. This electronic movement can be used as a medium for the transport of energy.

1.2.1. Electric Voltage, Current, Energy, Power

Electric voltage is analogous to hydrostatic pressure. Looking at the diagrams below, it should appear that there is no flow of water occurring in either of the two cases because the water level is identical in both containers. In electrical terms, we would say that electric current flow does not occur if there is no *difference in voltage* level.

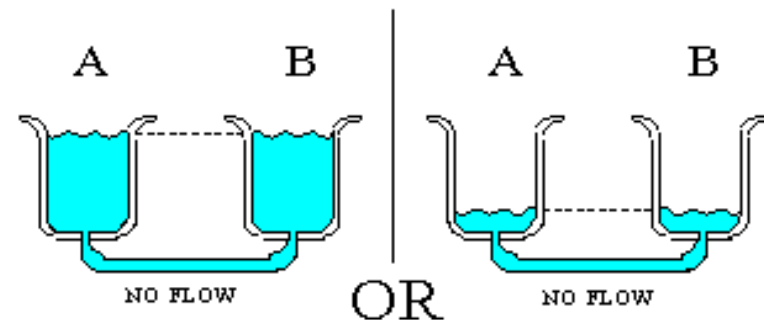

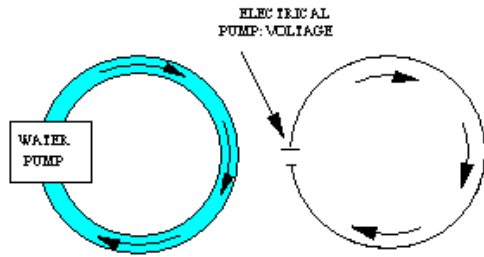

For water flow to occur, the level in tanks A and B must be different, as illustrated below. Electric current follows similar rules: it is the *difference* in voltage

level between two points that allows current to flow. Voltage is therefore relative: it refers to a difference between two points (often, one reference is *ground potential*). Voltage *difference*, measured in **Volt**, produces electric current.

We count water by the liter, and water flow in liter per second. Electric charge is evaluated as a group of electrons, a group being 6,280,000,000,000,000 electrons, also called **1 Coulomb** (electrons are very small). When 1 Coulomb per second flows in a wire, we have a current of 1 **Ampere**.

Water flow will occur for as long as there is a difference in level between the two tanks (left below), but eventually, the level will become the same, and flow will stop. In this case, the system has expended its available energy. The rotating propeller illustrated in the diagram below is a recipient of the energy of the system.

It can be understood that at any moment the ability of the system to turn the propeller is dependent on the pressure difference between the two tanks, as well as on the flow of water in the pipe.

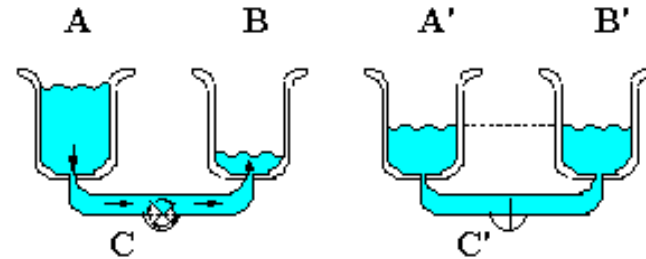

Electrical systems are analogous: **power** is equal to **voltage** (pressure) multiplied by **current** (water flow). The unit for electrical power is the Watt.

$$1 \text{ Watt} = 1 \text{ Volt} \times 1 \text{ Ampere} = 1 \text{ Joule/sec.}$$

Energy and power are related by a time metric. Power refers to an instantaneous situation, whereas energy implies a process that covers a certain interval of time. For example, a truck filled with heating oil corresponds to a given *energy* value for heating. The *power* of this truckload of heating oil depends strictly on how fast the oil is burned. If all is burned in a tiny fraction of a second, the power output of the tank of oil could, for that brief instant, be equal to that of the sun. On the other hand, if the oil is used over months, the average power may be quite modest. Both scenarios use the same amount of energy, but over very different time intervals.

The analogy with water can be continued. Imagine a water pump circulating water in a circular pipe.

The flow of water will be limited by friction of the water in the pipe. An electric circuit is very similar. An electric source, for example a *battery*, can circulate electric current in a wire. The current is limited by the electrical **resistance** of the wire.

Another interesting case is that in which a piston circulates water in an alternating motion inside a circular water pipe (right). There would be no net flow of water in the circuit over time, but energy from the water's motion would be available anywhere along the pipe, since water flow can be used for energy (think of a water mill). In the electrical circuit, an electrical **alternator** acts to push current in one direction and then in the other, alternating very rapidly.

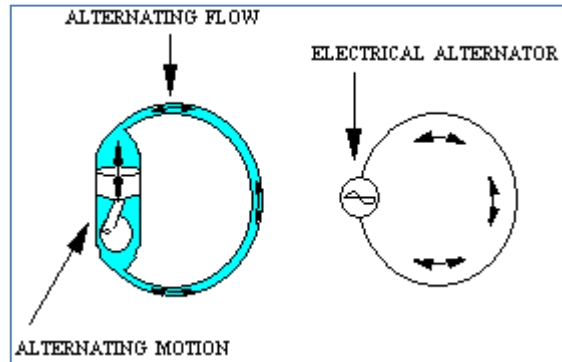

In commercial systems, the frequency of alternation is 50 or 60 Hz (50 or 60 cycles per second), and alternating current circuits are the predominant form of electricity distribution. The voltage delivered to households worldwide ranges from 100 to 240 V.

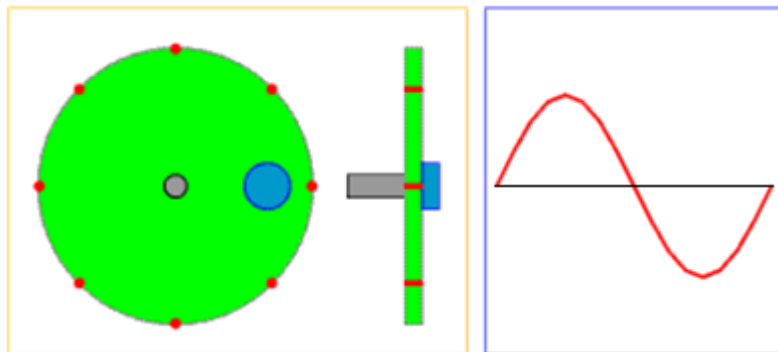

In alternating current circuits, a plot versus time shows how voltage and current vary over every successive cycle. In power sources based on circular motion (such as the piston driven by a wheel in the water circuit above, and in electrical alternators), the wave shape is a sinewave.

A *sinewave* is generated by the vertical motion of a marker (blue) fixed on the perimeter of a rotating wheel, as shown in the drawing.

When electricity consumed in a network exceeds supply (the driving force), the rotating alternators slow down under the strain, and the frequency drops slightly. If demand lowers, the extra energy available goes into spinning alternators more quickly, and frequency rises. So, network operators have to balance their supply with changing demand continuously. This balancing act keeps wired clocks connected to the utility supply exactly on time.

Frequency Metrics

1 cycle/second = 1 Hz.
 1,000 Hz = 1 kHz.
 1,000,000 Hz = 1 MHz.
 1,000,000,000 Hz = 1 GHz.
 Period (time of a complete cycle) = $1/f$.
 At 60 Hz, $1/f = 0.01666 \text{ sec} = 16.66 \text{ msec}$.

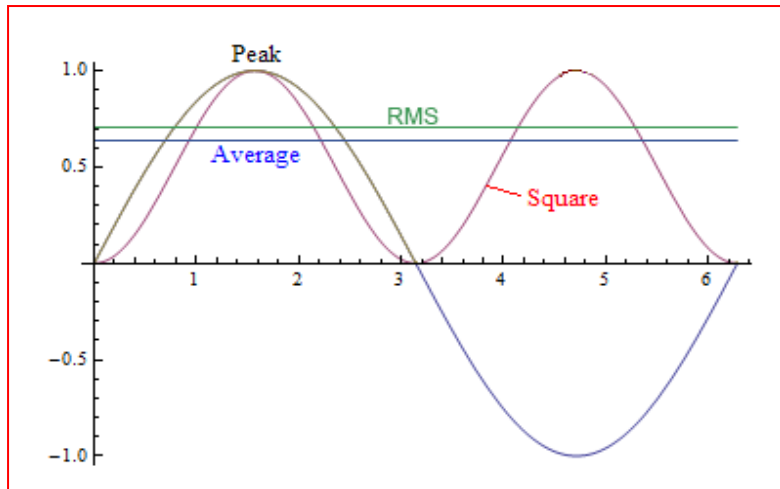

A single cycle of a sinewave is shown.

Because voltage and current amplitudes in a sinewave vary over time, they can be described by 4 various terms, as follows:

1. **Maximum** (or Peak) value = the highest positive or negative value reached in the cycle (amplitude of 1, above).
2. **Instantaneous** value = specific value at any given time (any amplitude between -1 and 1 above).
3. **Average** value = arithmetic mean, without sign, of all instantaneous values in a cycle (0.637, above).
4. **RMS value, the Root-Mean-Square** (or “effective”) value.

When used in electrical circuit calculations, this fourth value yields *accurate evaluations of actual energy and power*.

This RMS value is so useful, that unless otherwise noted, it is the one that is assumed in quotes, or displayed on instruments in all ac work.

The RMS value is obtained by taking first the square of the variable at every instant in the cycle (this first calculation is illustrated by the red trace in the figure). These squared values are then averaged over the cycle. And finally the square root of the resulting average is used. The following relation holds:

$$E_{\text{max or peak}} = \sqrt{2} E_{\text{rms}} = 1.4142 E_{\text{rms}}$$

1.2.2. Ohm*'s Law

Two simple equations are regularly used in the assessment of electrical problems, *Ohm's Law* and the *Power Equation*.

$$\mathbf{V \text{ (Volt)} = I \text{ (Ampere)} \times R \text{ (\Omega or Ohm)}}$$

For example, 100 Volts are observed across a load of 10 Ω passing 10 Amperes.

Ohm's Law allows the computation of currents passing through electrical elements, according to applied voltage.

There are 3 categories of common electrical elements (shown), and the simplest one is the resistor, directly concerned with Ohm's Law.

Problem 1. A 220 V source passing a current of 6 A is loaded by how many Ohms? How much current passes through a 40 W bulb, at a voltage of 120 V?

* Ironically, Georg Simon Ohm misunderstood resistance. He believed that the power of electricity derives from the resistance of the wire through which it travels.

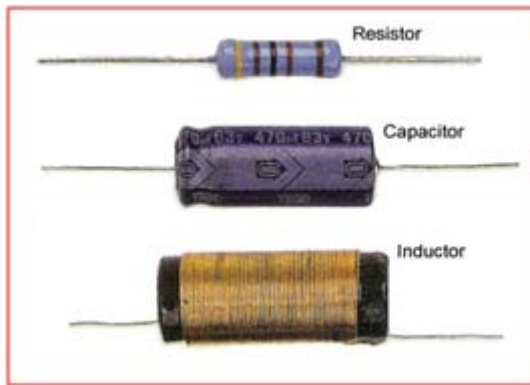

Electrical loads, such as the *human body*, can be represented in their **ability to pass electric current** by a resistance of approximately **1000 Ohm**.

Ohm's Law

Compute the ac current flowing through a 72 Ohm bulb connected to domestic utility voltage.

$$V \text{ (in Volt)} = I \text{ (in Ampere)} \times R \text{ (in Ohm)}$$

$$I = \frac{V}{R} = \frac{120 \text{ Volt}}{72 \text{ Ohm}} = 1.67 \text{ Ampere}$$

1.2.3. Kirchhoff's Rules

The general conceptual framework allowing the solution of electrical circuits is stated by Kirchhoff's rules.

To properly apply Kirchhoff's rules, one must know about a circuit's *nodes* and *branches*. A node is a point in an electrical circuit connected to at least 3 electrical elements (see "Loop 2" below). A branch is a connection between nodes.

Kirchhoff's current rule conserves charge: all the charges flowing in and out of a node must add to 0. When applied to a node, this rule creates relations between currents flowing in circuit branches.

Kirchhoff's voltage rule sums to 0 all voltages along a closed circuit. If one defines a closed path made of at least two branches, then the sum of voltages along the path add to 0.

These current and voltage rules can be used to solve electrical circuits by building algebraic conditions written in terms of the values of the elements of the circuit, the currents flowing in the branches, and the voltages observed on the elements.

For circuit analysis, we first arbitrarily decide on directions for

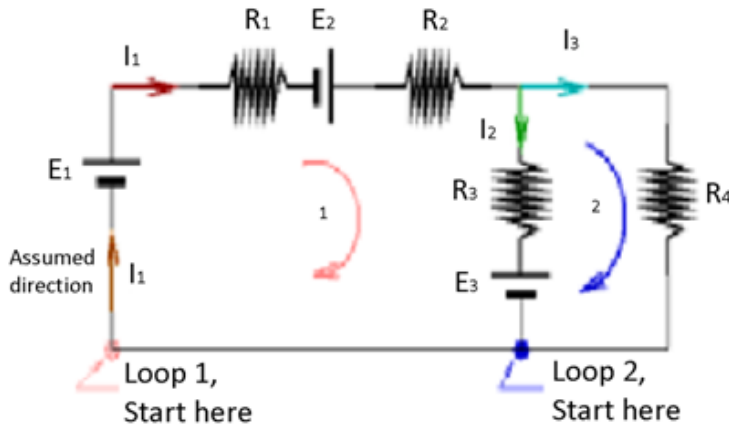

currents in each branch of a circuit.

Since at nodes the current divide into two parts (at least), we have current equations:

$$I_1 = I_2 + I_3 \quad (\text{charge conservation}).$$

Voltage equations are formed from a *starting point* for each loop. We incorporate to the equation positive voltage terms for elements that increase current flow and negative terms for elements that oppose it:

$$\varepsilon_1 - I_1 R_1 + \varepsilon_2 - I_1 R_2 - I_2 R_3 - \varepsilon_3 = 0$$

$$\varepsilon_3 + I_2 R_3 - I_3 R_4 = 0$$

The 3 equations above together define all conditions in the circuit.

In the computation of electrical circuits containing more than one element, impedances in series (ex. R_1 and R_2) are added ($R_3 = R_1 + R_2$), while impedances in parallel (R_1 and R_2) are added as their inverse values ($1/R_3 = 1/R_1 + 1/R_2$). See problem 2.

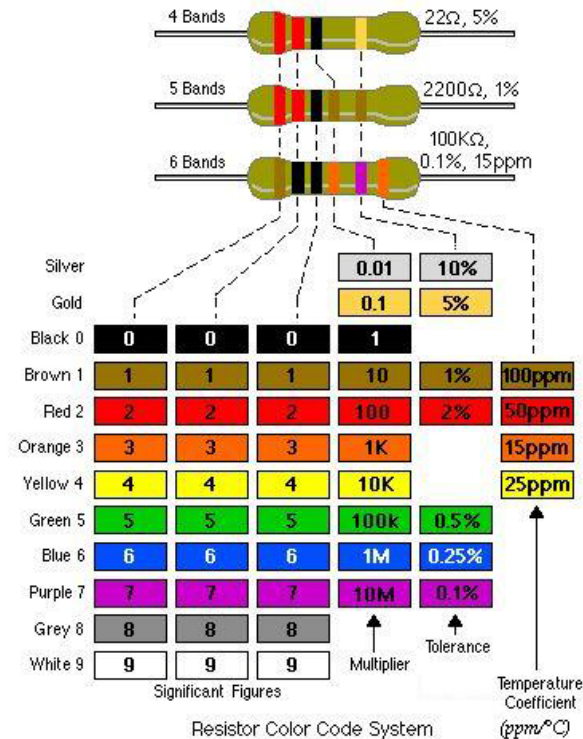

Physical resistors are mostly of fixed value, but can also be built to adjust to many different values. A volume control (“potentiometer”) is made of a mobile metal contact pressed against a carbon track resistor, as shown below.

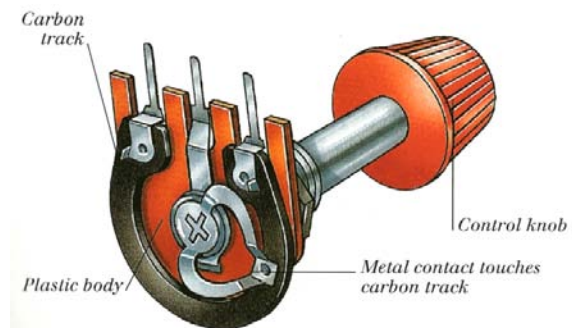

1.2.4. Power Equation

$$W \text{ (Watt)} = V \text{ (Volt)} \times I \text{ (Ampere)}$$

For example, 100 Watts is spent in a bulb passing 1 Ampere under 100 Volts.

Combining Ohm's Law and the Power Equation yields the equivalent forms:

$$W \text{ (Watt)} = R \text{ (\Omega or Ohm)} \times I^2 \text{ (Ampere}^2\text{)}$$

$$= V^2 \text{ (Volt}^2\text{)} / R \text{ (\Omega or Ohm)}$$

Power Equation

What is the power of a 72 Ohm bulb connected to sector voltage?

$$W \text{ (in Watt)} = V \text{ (in Volt)} \times I \text{ (in Ampere).}$$

$$120 \text{ Volt} \times 1.67 \text{ Ampere} = 200 \text{ Watt}$$

1.2.5. AC Circuits

Analysis of direct current (dc) electrical circuits uses mostly the concept of *resistance* (**R**), which describes the impediment to the passage of constant electrical current.

Analysis of alternating current (ac) electrical circuits adds the concept of *reactance* (**X**), which describes the impediment to the passage of the alternating component of electrical current. The most general definition of how an electrical load impedes the passage of electrical current is lumped into a single concept for the analysis of all electrical circuits at any frequency: *impedance* (**Z**).

It characterizes a given electrical load into two separate categories, R (*resistance*) and X (*reactance*) as:

$$Z \text{ (Ohms)} = R \text{ (Ohms)} + i X \text{ (Ohms)}.$$

Reactance (X) is itself divided into two sub-components: *capacitive reactance* (**C**) and *inductive reactance* (**L**).

DC only	Resistance, "R" in Ohms	$V = I R$
AC only	Reactance, "iX" in Ohms	$V = I i X$
General	Impedance, "Z" in Ohms made of three sub-types: resistive, inductive and capacitive.	$V = I Z = I (R + iX) = I (R + i (\omega L - 1/\omega C))$

1.2.6. Impedance

An analogy between mechanics and electricity can be drawn to make impedance more intuitive.

Imagine applying a force to a weight coupled to a spring that experiences friction against a plane (figure below). The total force (T) on the weight is:

$$T = M \frac{\partial^2 x}{\partial t^2} + F \frac{\partial x}{\partial t} + K x$$

where M is the mass of the object (inertia), F is the friction experienced by the object against the plane while it is moving at speed v ($\frac{\partial x}{\partial t}$), and K is the restoring force applied by the spring, according to displacement (x).

Note that friction (F) is the only term that *dissipates* energy, while both mass (M) and the spring (K) *store* energy, and may counteract one another.

The electrical analogue of the equation above would state the total voltage (T) applied to an electrical load as:

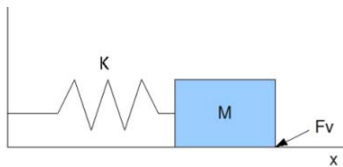

$$T = L \frac{\partial^2 q}{\partial t^2} + R \frac{\partial q}{\partial t} + \frac{q}{C}$$

where L is inductance, R is resistance, C is capacitance and q represents electric charge. Here again, resistance (R) is the only term which dissipates energy, while inductance (L) and capacitance (C) store it, and may oppose one another.

You could imagine that the spring absorbs energy (and returns it) like a capacitor.

The inertia of the block corresponds to the energy stored in the magnetic field of an inductor. The mass, if in motion, persists in its motion until the motion energy is dissipated by friction, much as the current dissipates in a resistor.

We will study capacitance in some detail (1.2.8), but our discussion of inductance will be limited (1.2.7).

The factor “ i ” (j is also used) in the table above means “out of phase by a quarter-cycle in reference to voltage applied”.

When an impedance is purely capacitive, current *leads* voltage by a quarter cycle.

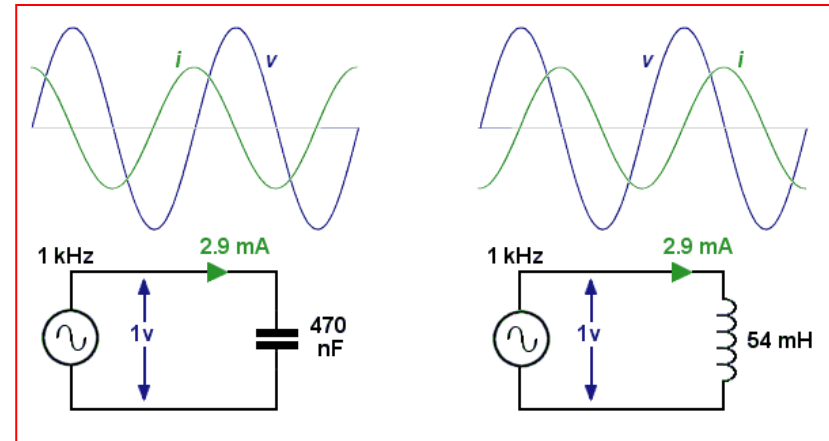

When an impedance is purely inductive, current *lags* voltage by a quarter cycle (figure).

Capacitive loads tend to resist changes in *voltage*, while inductive loads tend to resist changes in *current*.

Reactance (X) integrates the contributions of any capacitances ($X_C = -1/(\omega C) = -1/(2\pi f C)$) and

inductances ($X_L = \omega L = 2\pi f L$) in a circuit.

In this course, we will not study advanced concepts of impedance, but only the most elementary ones.

One can deduce from Kirchhoff's rules above that the values of capacitors in parallel can be added to find the equivalent single capacitor.



Problem 2. Calculate the single resistance equivalent to the following resistors in series: 2300 Ω , 6 M Ω , 0.1 m Ω , 16 k Ω . Which element has the most influence? Calculate the single resistance equivalent to the following resistors in parallel: 2300 Ω , 6 M Ω , 0.1 m Ω , 16 k Ω . Which element has the most influence?



1.2.7. Inductance



Inductance is an electrical property embodied as an “inductor”. An inductor is formed by an electrical wire wound onto itself (say, on a bobbin), but carrying thin insulation (usually varnish) to avoid short-circuits between loops. A core of **magnetic material** is often placed within the coil to multiply



Basic electrical symbols.

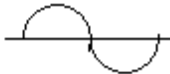

 *A dangerous voltage (above 1000 V).*



 OR  *Protective conductor terminal (ground potential). For protection against electrical shock in case of a fault. A wire so identified should be connected to ground before operating equipment.*

 OR  *Frame or chassis terminal. Normally includes all exposed metal structures.*

 *Alternating voltage source.* 

 *Direct voltage source.* 

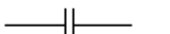
 *Resistor.* 

 *Capacitor.* 

 *Inductance.*

the basic inductance supplied by the wire loops. An inductance stores energy in the form of a *magnetic field* surrounding the coil.

The inductance L (in Henry) of a coil of wire is proportional to the number of turns (N) squared, the coil area (m²), the magnetic permeability of the medium (μ for free space = 4π x 10⁻⁷ H/m), and inversely proportional to coil length (m).

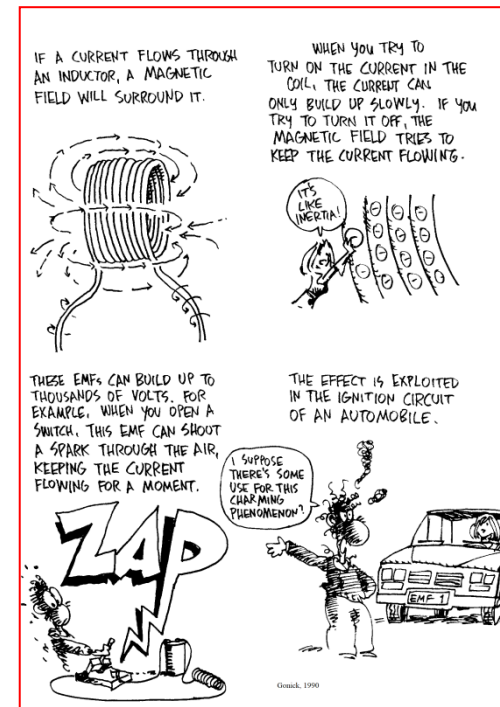

$$L = \frac{\mu N^2 A}{l}$$

Inductors can be of various constructions, as shown below.



Inductance manifests when there is an attempt to **change a current flow** within an inductor, by using its stored magnetic energy to oppose that change: an *inductive* element in an electrical circuit opposes any change to the magnitude of electrical current.

Therefore, inductors resist alternating currents, but are transparent to continuous currents.

Inductance is symbolized as L, the unit is the Henry (H). To obtain a circuit parameter in Ohm usable in the electrical circuit computation, elements of given inductance can be transformed into Ohm values using the following expression

$$\text{Value in Ohm of an Inductance} = 2\pi fL$$

where L is the Inductance in Henry and f is the frequency in Hertz. For example, an inductance of 1 μH at 1 kHz has a value of

$$\text{Value in Ohm} = 2\pi \times 1000 \times 0.000001 = 0.0063 \Omega.$$

Once the Ohm value is known for an inductance, it can be analyzed within an electrical circuit exactly as a resistance *if the circuit functions at a single frequency* (which will always be the case in this course), and if we ignore phase shifts.

The energy (Joules) stored by an inductance of value L (Henry) passing a current I (Ampere) is equal to

$$E = \frac{1}{2} LI^2$$

Industrial devices containing large inductances are **relays**, **electric motors** and **transformers**.

Relays are electro-mechanical switches that use the magnetic field of a coil (solenoid) to move electrical contacts. They are extensively used in industrial control circuits.

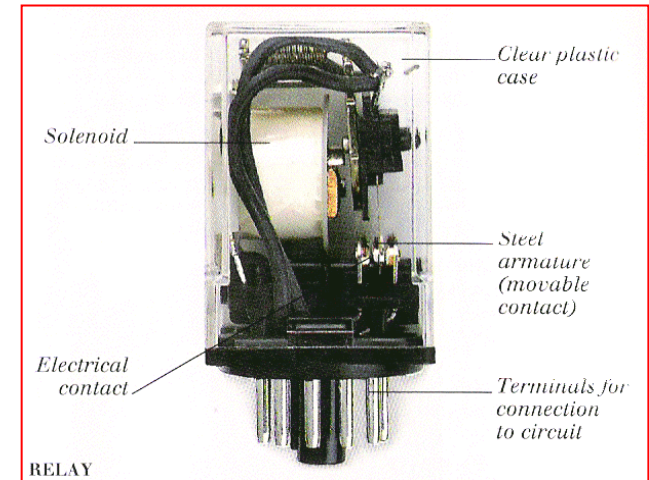

Electric **motors** rated at 746 kW (1000 HP) or more consume about 30% of all electrical power.

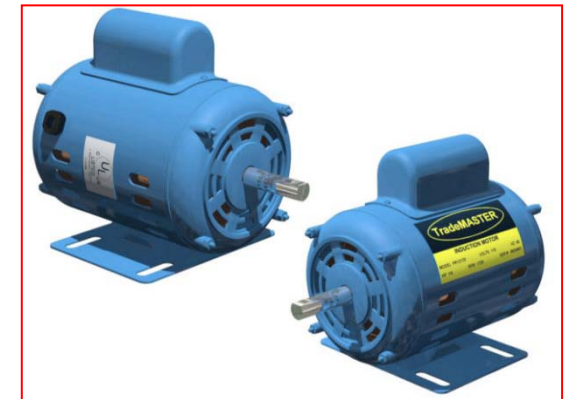

By virtue of the design of the electrical grid (see later in this chapter), the whole of the electrical power consumed transits through electrical **transformers**, which consist of a pair of inductors wound on a common magnetic core.

Inductor Safety

The most important notion to remember about safety associated with inductances is that ***interrupting the flow of current through an inductance generates a large reactionary voltage***, which can result in a powerful electric arc.

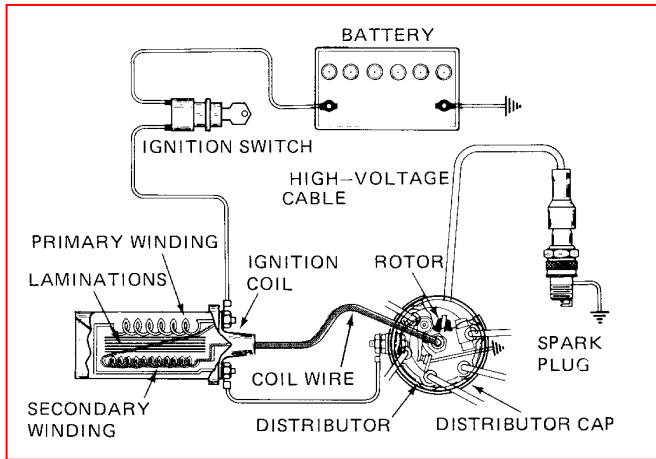

Crouse & Anglin 1987, Automotive Mechanics

The ability of inductances (“ballast”) to generate large voltages when current is interrupted is used to start the arc in fluorescent tubes, and in the ignition of a car. Surges as high as 47,000 V are produced by the car ignition’s coil secondary when the primary winding of the ignition coil is opened by a mechanical or electronic switch. This surge is channeled to the spark plugs by the distributor.

Therefore, *opening of switches controlling substantial current to large motors or transformers* (such as in an industrial setting) *generates powerful sparks* which can only be handled safely by switches with the required interruption capacity.

1.2.8. Capacitance

Capacitance is an electrical property embodied as a “capacitor”. It consists of two electrically insulated metallic plates, one charged with negative and the other with positive electric charges. **Dielectric material** can be



placed in the gap between the two electrodes to multiply the value of a capacitor. A capacitor allows storage of energy in the form of an *electric field* between two plates. The capacitance between two plates can be computed as:

$$C = \epsilon_0 \frac{A}{d}$$

where C is the capacitance in Farads, A and d are area and distance of the plates (m² and m) and $\epsilon_0 = 8.85 \times 10^{-12}$ Farads/meter. This will be reviewed later in *Bound Charges* and *Dielectric Constant* sections of Chapter 3.

In order to obtain maximum capacitance, the two plates are kept as close together as possible (small “d”) without touching one another, and are made as large in surface as possible (large “A”). Capacitors are present in every section of electronic circuits, coming second only to resistors in frequency of use. Capacitors can be of various constructions, as shown below. At low values of capacitance, capacitors may have the appearance of small ceramic objects of ~ 1 cm or less. Many are seen on any electronic circuit board. At large values, they may present as a metallic can (~ 1 cm to 10 cm) containing a pair of metallic foils rolled into a tight cylinder, and insulated from one another by metal oxide, or a thin layer of oiled paper.

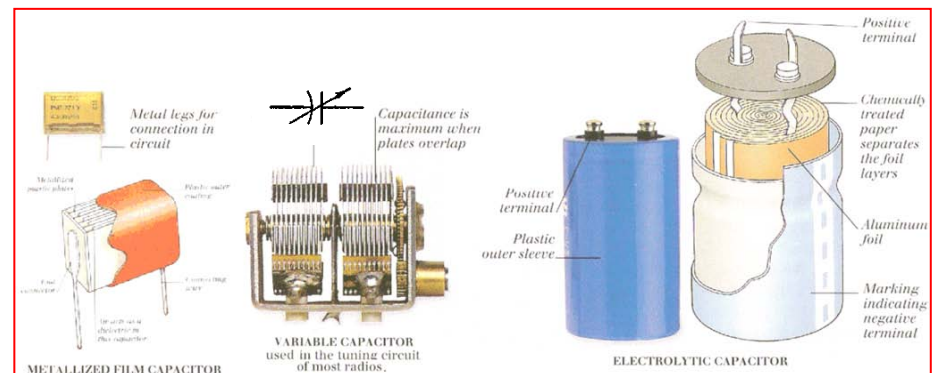

A *capacitor* in an electrical circuit opposes any **change to voltage**, and this is why capacitors are often added to regulate the output voltage of power sources. When power is drawn from the source, capacitance manifests by contributing some of its stored energy to maintain the previous output voltage of the source.

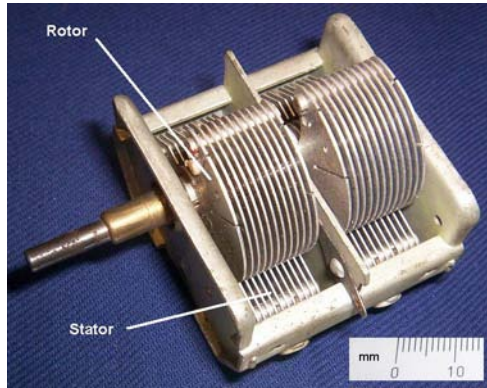

Capacitors block continuous currents, but are relatively transparent to alternating currents. They can shape, filter, shunt aside or block electrical signals, according to their frequency.

Capacitors under alternating voltages can be compared to a water pump connected to a pipe that is obstructed by an elastic membrane. If we try to push water through the pipe, the membrane will stretch, storing energy until the water's pressure is counter-balanced by the membrane tension. A larger area membrane corresponds to a larger "capacitance" and larger ability to store energy or water. The stretched membrane is capable of storing energy, but it is not possible to pass water continuously through the system without the membrane bursting. However, *energy can be transmitted across the membrane* if the water flow is alternating, while not allowing the membrane to be over-stretched.

The unit of capacitance is the *Farad*, more commonly the *micro Farad* (μF). It represents the amount of charge stored in a capacitor per Volt of polarization. To obtain a circuit

parameter in Ohm usable in the computation of electrical circuits, elements of given capacitance can be transformed into Ohm values using the following expression

$$\text{Value in Ohm of a Capacitor} = \frac{1}{2\pi f C}$$

where C is the Capacitance in Farad and f is the frequency in Hertz. For example, a capacitor of $1 \mu\text{F}$ at 100 kHz has an impedance of 1.59Ω .

$$\text{Value in Ohm} = 1.59 \Omega = \frac{1}{2\pi \times 100,000 \times 0.000001}$$

Once the Ohm value is known for a capacitor, it can be analyzed within an electrical circuit exactly as a resistance *if the circuit functions at a single frequency* (which will always be the case in this course), and if we ignore phase shifts. This transformation to Ohms is particularly useful to gauge the

Capacitive Impedance

What is the capacitive impedance of a $10 \mu\text{F}$ capacitor at 60 Hz?

$$Z = \frac{1}{\omega C} = \frac{1}{2\pi f C} = \frac{1}{2 \times 3.14 \times 60\text{Hz} \times 10 \times 10^{-6} \text{F}} = 265 \text{ Ohms}$$

magnitude of currents in various practical situations.

The amount of energy (Joule) stored by a capacitor of value C (Farad) charged at a voltage V (Volt) is equal to:

$$E = \frac{1}{2} CV^2$$

Capacitors are commonly used to store electrical energy, and they can maintain this energy at the ready for considerable periods of time, even if an electrical circuit has been disabled.

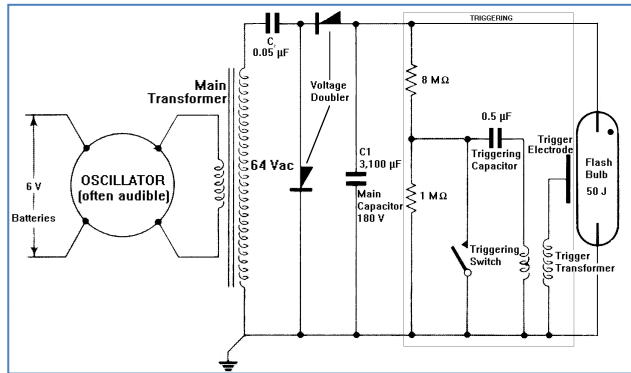

The electrical circuit of a Flash: 6 V batteries power an oscillator that drives a transformer. The transformer increases the

voltage to a high level. This high voltage is rectified and directed to a capacitor (C1). When full charge is reached, a special circuit is used to trigger the flash bulb through an ignition electrode near the bulb.

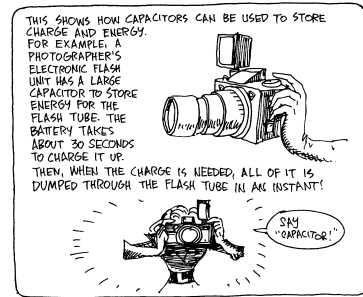
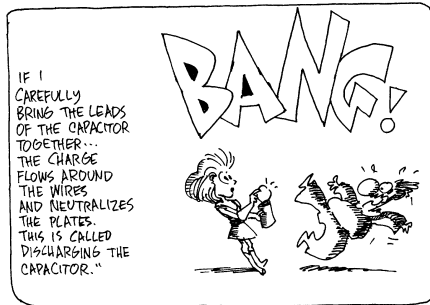

Gonick, 1990

We use the concept of *capacitance* extensively in this course because it is the main parameter of **electrostatic induction**, which explains the transmission of electrical power *without any apparent physical link* to a power source. This phenomenon of **action at a distance** is the cause of safety hazards as well as of fear of electricity among workers (specifically, of *ungrounded fears*).

The Leyden jar was the earliest type of capacitor, invented in 1745. It was used, among other things, to cure "paralysis, flatulence and arrogance".

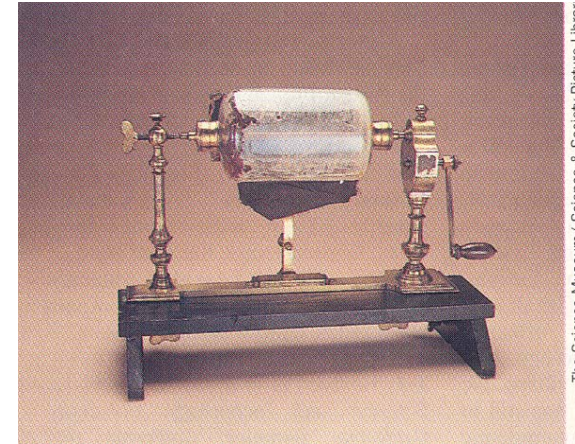

The Science Museum/ Science & Society Picture Library

Problem 3. In a correct application of the decimal system, how should centipedes and millipedes be named?

Problem 4. Calculate the Ohm value of a $1 \mu\text{F}$ capacitor at 60 Hz. How much current flows through this capacitor if 100 V ac is applied?

Problem 5. At what frequency is a $1 \mu\text{F}$ capacitor equivalent to 1000Ω ?

Capacitors have an enormous number of applications in electronics and computing.

To keep track of what it is doing, a computer processes, but also stores information, and retrieves it at a speed that would ideally keep pace with the processor. Computers use memories based on capacitors for this purpose, dynamic random access memory (DRAM). DRAM is used either on narrow add-on circuit boards, or embedded on the processor itself (cache) to store small amounts of information. The capacitors of DRAM, although very fast, are leaky, and must be refreshed about 15 times per second to keep maximum charge.

Longer-term memory storage can be achieved by the capacitors installed on *flash memory*, the type used in USB sticks. In this case, the tiny (20 nm) capacitors and their circuits lose so little charge over time that they retain information for 10 years

without input of energy. But this is achieved at the cost of speed, and flash memory is only marginally faster than a hard disk.

Capacitor Energy

How much energy is stored in a 10 μF capacitor at 120 V?

$$E = \frac{1}{2} CV^2 = \frac{1}{2} \times 10 \times 10^{-6} \times (120 \text{ V})^2$$

$$E = 72 \text{ mJoule}$$

1.2.9. Practical Measurements

In evaluating any electrical problem, the magnitude of voltage, current, and whether circuit parts are effectively connected (by low resistance) are important. Values of voltage, current and resistance are commonly measured with a single multi-purpose instrument called a multimeter (left). Safe use of a multimeter requires some understanding of electricity.



When used in **voltage** measurements, a multimeter offers a **high resistance** to current flow across its leads ($\sim 10 \text{ M}\Omega$). When used in **current** measurements, it offers a **low resistance** to current flow ($\sim 1 \Omega$). Finally, when used in **resistance** measurements, an internal **battery** is used to circulate currents in the object being measured.

- ✚ Voltages should not be applied to the leads of a multimeter in the *current* measuring position (“A” as selected by the instrument’s main knob), as very high currents would pass in the low resistance of the meter, resulting in its destruction, possibly also in an **electric arc**.
- ✚ It is not appropriate to use a multimeter in the *resistance* position (“ Ω ”) on a device under power. When measuring resistance, the instrument uses an internal source (a battery) for circuit evaluation. Safe, as well as correct resistance readings can be had only if the circuit being evaluated is inactivated (disconnected from any power source).
- ✚ Any *multimeter* has maximum voltage and current limits. Therefore, the instrument should not be used in the *voltmeter* or *current* positions (“V” or “A”) to measure *voltages* or *currents* beyond its rating.
- ✚ The position on the main knob of some multimeters needs to be appropriately selected for dc (–) or ac measurements (~).
- ✚ The leads connected to the points being tested have exposed metal ends. If these exposed metal lengths are longer than the distances insulating electrical components in the circuit under investigation, there is a danger of accidental short-circuits, which again result in electric arcs.

MEASUREMENTS AT HIGH VOLTAGES

A live-line stick (left, below) can be used to operate overhead switches at a distance. A special voltage detector (right, below) can be used on the end of a live-line stick in the maintenance procedures of the distribution network (to insure the line is safe to touch).



1.3. Description of Electric Power Networks

1.3.1. Generation

Electricity can be produced by the energy of falling water. The sites of the dams are remote in most cases. The power, produced by the turbines and picked-up through *electromagnetic induction* in giant alternators, is passed through large transformer

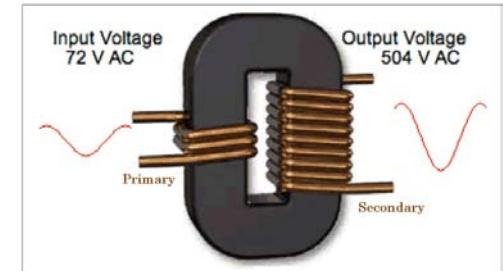
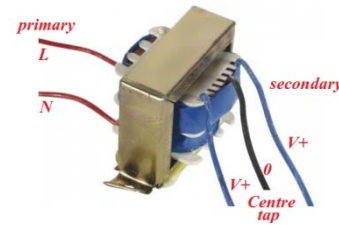

units nearby, which configure the power to a low current/high voltage form. The energy efficiency of these transformers is as much as 99%. An electrical transformer allows passage of all of the electrical power through it, but gives an opportunity to change the **ratio of voltage to current** between the primary and secondary coils. The supplementary wire (center tap) in the transformer photograph above is welded on the center of the secondary winding.

The transformer stores the energy from the primary in the form of magnetic flux, and restores it to the secondary in a different voltage-to-current ratio. The ratio of voltages between primary and secondary is dependent on the ratio of coil turns around the magnetic core between primary and secondary.

$$V_2 = V_1 \frac{n_2}{n_1}$$

A widespread type of power transformer is the post-mounted utility unit (see 1.3.3) seen in the streets.

1.3.2. Transmission

The power equation (1.2.4) shows why a high voltage and low current form of energy is desirable to transport power over large distances. The power available from the line is the product of its output current and output voltage. Increasing the current means that it is necessary to provide a larger conductor cross-section (a conductor has a fixed current capacity related

to overheating), and therefore increases both metal cost and weight.

If voltage is raised, this simply increases the *electric stress* on the insulation, which in the case of high voltage transmission lines is *air* (conductors are not covered by solid insulation).²

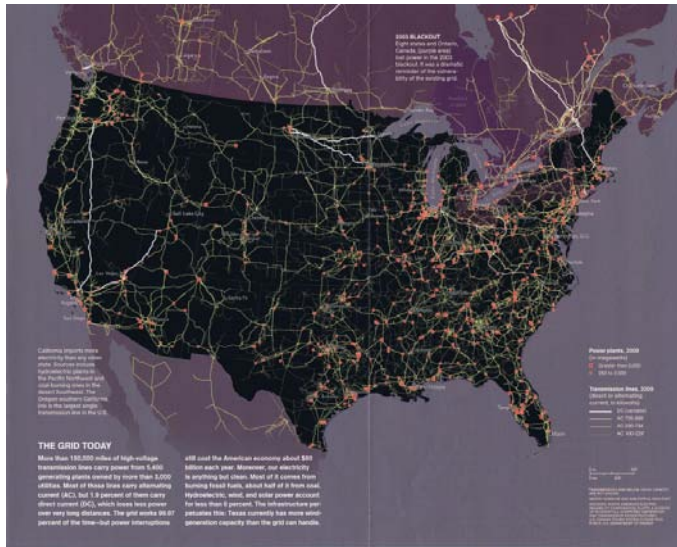

North American transmission lines above 100,000 volts.

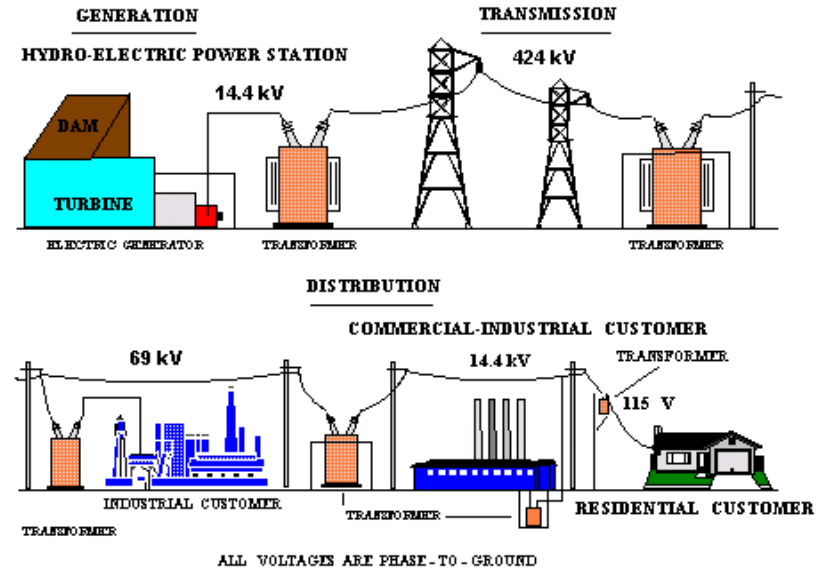

The transmission network carries electricity over the long distances separating the generating stations from the customers at voltages ranging from 44,000 V to 1,000,000 V, depending on needed power capacity.

1.3.3. Distribution

As the transmission line nears the customers, it enters a distribution station, which converts its power to a *high current and low voltage* form. The use of electric power at very high voltage would be impossible in small appliances where insulation distances are small. So, the transmission voltages are lowered, initially, to values ranging between 4,000 and 34,500 Volts.

These voltage levels occur on the utility posts in our streets.

² The voltage can be raised to the point of dielectric rupture of the air (~25 kV/cm), but no further. This is why high voltage transmission line conductors are often in bundles, generally four parallel conductors on a square, thereby reducing the electric field applied to the air. The transmission conductors themselves are about 4 cm in diameter and made of stranded aluminum wires. Providing for the large insulation distances necessary to avoid flashover necessitates large towers, however.

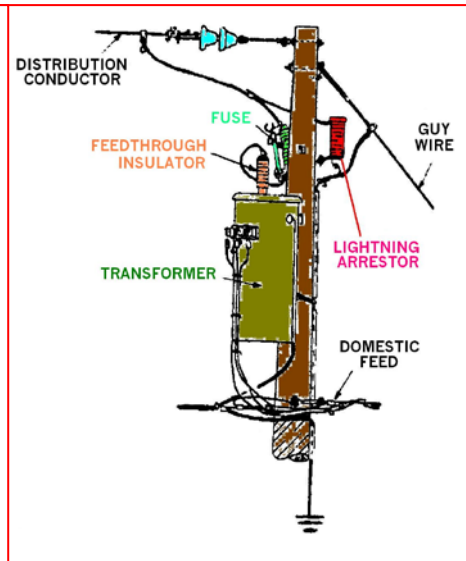
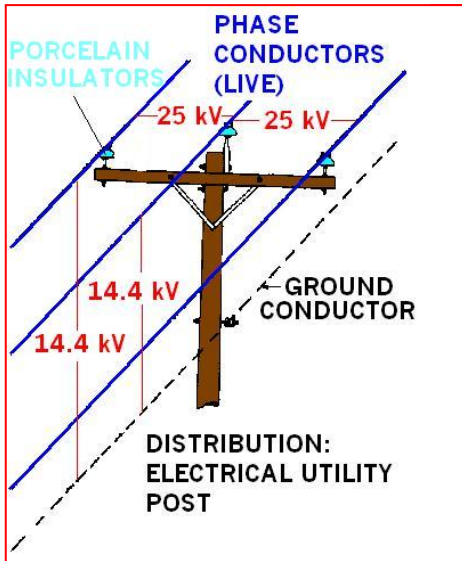

Distribution can also be achieved by an underground configuration. Where density warrants, mostly in cities, electrical lines are placed underground. Cables can be buried directly, or be passed through tubes held by poured concrete. At intervals, vaults topped by manhole covers, contain transformers and switching equipment.

1.3.4. Electrical Power demand over Time

A frequent overhead configuration is a wooden post bearing a horizontal strut on its top, which supports three porcelain insulators holding each a bare conductor. Every year in Guam, snakes that bridge the bare conductors cause as many as 100 electrical outages. A *grounded wire* is installed at a slightly lower height on the post. Also, the same post frequently carries at an even lower level a telephone cable.

The distribution system involves a few other devices. The high voltage at the top of the wooden pole is connected through a large **fuse** (over-current protection) to a **distribution transformer** (gray or green cylinder at the top of posts). The transformer is grounded by the *ground wire* mentioned previously and sometimes also locally to a metallic spike in the earth, at the foot of the post. A **lightning arrester** connected between the high voltage wire and the earth is also often included.

Electrical utilities experience different power demands over hours, days, or seasons. For example, although some sectors of society may require a fairly constant daily energy demand (industrial), other sectors are highly variable (residential), as shown below. This results in a variable demand for total power

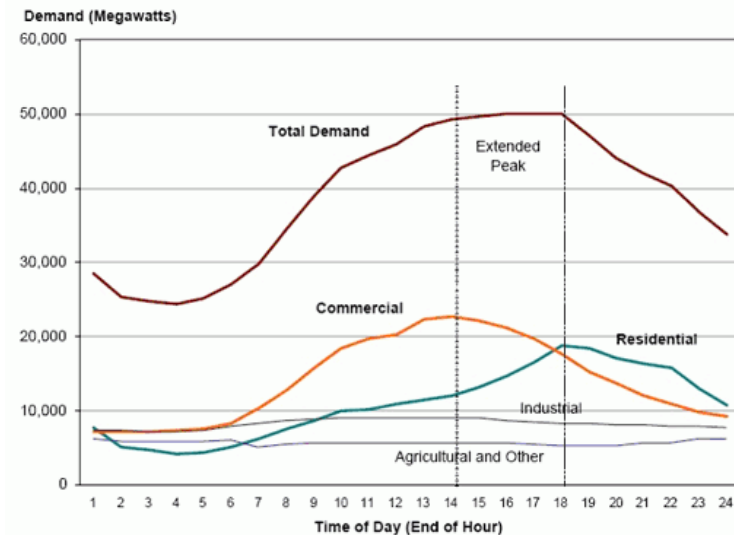

that can be met by constant base (hydro-electric dams) with the addition of peak installations (gas turbines) that are only activated at certain times. Utilities aim to flatten the demand by changing the kW-h/\$ rate to consumers for certain times of the day or seasons by using smart meter techniques (1.3.7).

1.3.5. Grounding as a Problem

Early electrical distribution systems were totally closed between source and load, as shown at the top of the figure below, with no connection to the earth. In the 1930's, the utility industry decided to change from the originally ungrounded distribution system to a grounded system. This change allowed a portion of the neutral current to return to the substation through the earth, as shown at the bottom of the figure. The neutral wire of the distribution system is connected to ground rods and/or other conducting materials in the earth (such as water pipes and systems), providing a path for the current into the earth. This became a common practice. Although the earth is not extremely conductive, it has extremely large volume. Metal spikes planted into the ground, particularly if they run



deep within the earth and below the freezing zone, allow electric charges to return very effectively to a source that is also grounded. This method of power transmission meant that quantities of copper could be saved by relying on the earth's mass to provide a return path instead of installed wire conductors. Although this method proved economical, it resulted in increases in the magnetic field exposure of populations, which were at that time believed to be without consequence [Preston 1989]. The reliance of utilities on earth grounding is an important reason why abatement of magnetic fields from power systems is a difficult problem (Chapter 4).

A second consequence was the contamination of ground return connections, given that the earth is not a perfect equipotential volume. And this contamination of the earth's ground by utility groundings had doubtful technical justifications beyond that of a cost-cutting measure [Zipse 2003].

Not only can 60-Hz and non-60-Hz components be present in the wires that deliver power as "dirty electricity" (see 1.3.9), they can also travel through grounding connections that every home is required to establish in order to insure basic electrical safety against shocks, as we will see in Chapter 2.

For utilities, using the earth to carry a portion of the current reduced electrical losses and consequently reduced the need for as many voltage adjustments. Thus, the previously ungrounded electrical distribution system progressively became a multi-grounded system which uses the earth to carry a fraction of the neutral current [Mairs 1994]. When it also became common for the utilities' power transformers to connect together primary and secondary grounds, the earth finally carried the majority of neutral current returning to the substation [Gonen 1986; Morrison 1963; Hendrickson, Michaud, Bierbaum 1995].

Electric currents in the earth that emanate from technologically developed systems are called ground currents. Ground currents are a mix of DC and AC, both of which can be continuous and/or pulsed or originate both from distribution systems of the electrical utilities and from electrical systems of consumers. These currents intentionally injected into ground transformed the earth and earthing wires into a source of sustained electrical potentials that is not biologically “safe”.

Bjorn Nordenstrom, among others, has suggested models that portray the bodies of living organisms as having electric circuits with small currents actually controlling life [Nordenstrom 1983]. Appropriate electric currents of small magnitudes within the circuits of the body are vital to good health. The bodies of living organisms generate these currents and naturally provide the magnitudes that afford good health.

Power frequencies up to 300 kHz are the most likely to influence biologic functions because normal bioelectric events often take place in those frequency regions [Bawin 1973].

Extensive grounding of the neutral in the distribution system forces electrical currents to be present in all materials making up the environment of living organisms, plugging them into the electrical circuitry of the distribution system [Raloff 1993; Burke 1991].

Within tissues, protons possess the highest rate of diffusion among all ions, and their loss would be the leading reaction driving tissues in an electronegative direction. Although most organic molecules behave as dielectrics, short distance electron transfers also occur within and between molecules [Trukhan, 1966; Rosenberg 1965; Cope 1963].

The presence of ground currents implies long-term, continuous exposure to low-level electrical currents that living organisms have to compensate for, resulting in stress.

Unfortunately, industry has been reluctant to investigate this source of stress on animals and humans. The traditional research model continues to assume that negative health effects are possible only in the presence of high voltage shocks (Chapter 2).

Livestock producers are especially aware that lightning or a fault in a distribution line can kill animals if they happen to be in the path of the electric current in the ground. Dairy operators are frequently required by state codes to construct equipotential planes in their barns as a means of avoiding electric shocks for cows. The stray voltage problems in the dairy industry, however, have shown that when the neutral of the distribution system is connected to the earth, the earth is neither a plane of constant electrical potential nor an electrically safe place, as small continuous currents (as low as a fraction of a microampere) can affect well being [Ontario Bill 161, 2016]. Because the cows are exceptionally sedentary and the barn’s equipotential plane is a good conductor which attracts a greater percentage of the ground currents, this causes the cows to be exposed to greater continuous currents, and frequently increases stray voltage effects [Dahlberg and Falk 1995]. Surveys and farm evaluations and investigations have provided a significant body of information concerning the effects of ground currents [Hartsell, Dahlberg, Lusty, and Scott 1994; Dahlberg and Falk 1995; Marks, Ratke and English 1995; Kelly 1998].

Electric currents in the earth also induce corrosion of buried metals such as pipelines.

The electrical solution to the grounding problem is to install a new neutral ground conductor that will allow ALL the neutral return current to flow unimpeded without using the earth back to the source substation transformer, except in the case of a fault, as is done in a house.

1.3.6. Domestic

The secondary winding of a distribution transformer outputs a voltage of 240 V between its two terminals, which become the RED and BLACK wires in the house's electrical box. At the

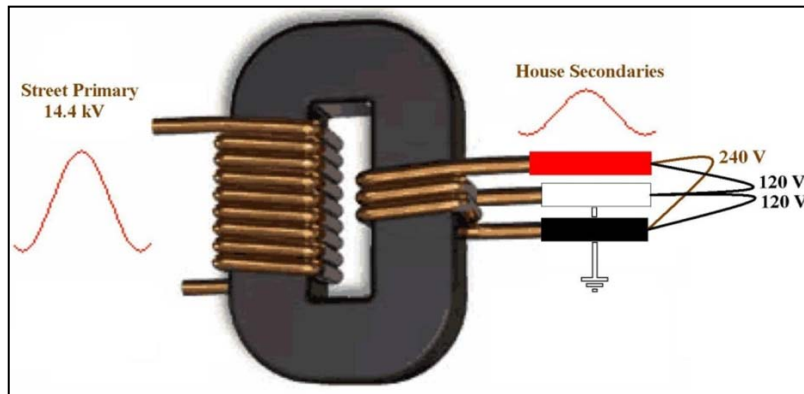

middle point on the secondary winding is connected a *center tap* conductor, which is brought to earth potential to become the WHITE wire. Between the RED and BLACK conductors, heavy domestic appliances requiring 240 V are connected (stoves or dryers, for example). Between the BLACK (or RED) and WHITE conductors, other electrical equipment needing 120 V are connected.

Voltages of 120 and 240 V can be safely insulated using **elastomers** (polyethylene or other), and wires so insulated are connected to a domestic customer's electric box. Note that until the distribution transformer, where voltage was stepped down to 240-120 V, electric power wires were isolated by *distance*

Time-Life Books, 1989

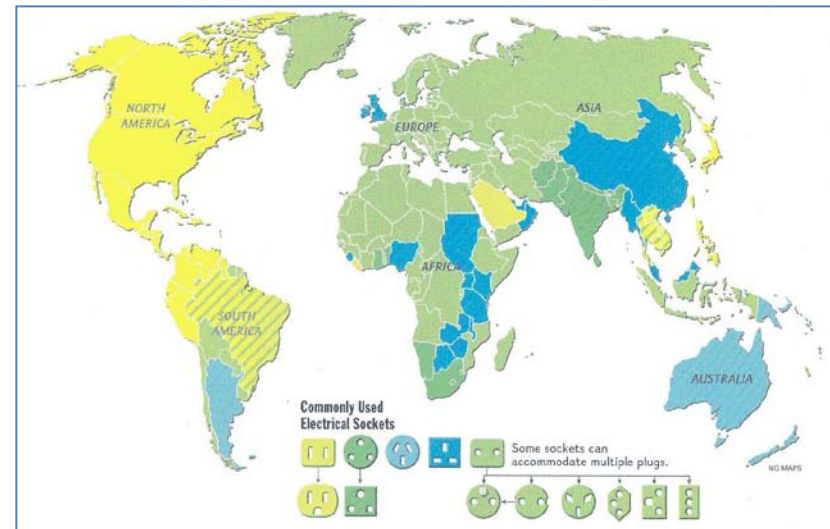
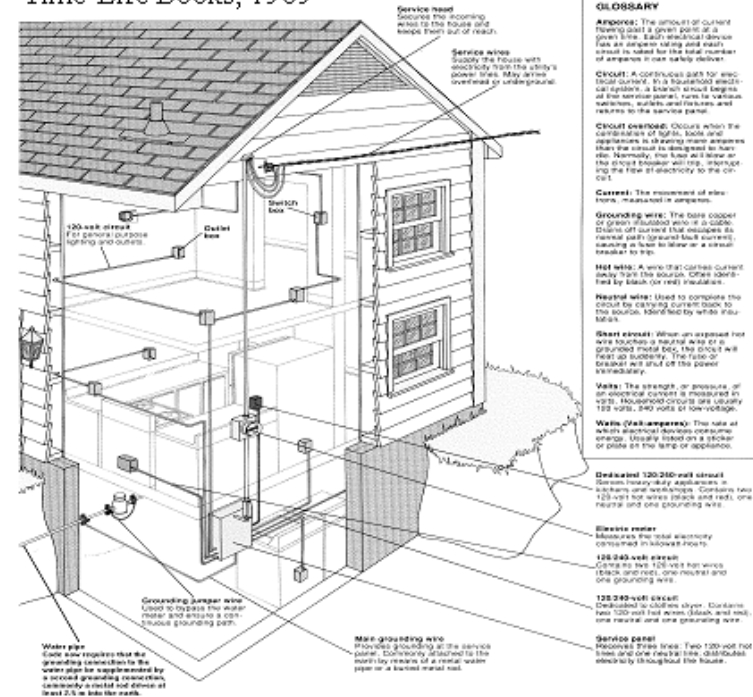

through the air as the only safety. Human contact with the naked wires traveling the streets could result in **severe injury** or **death**. Overhead line contacts account for about 60% of all electrical fatalities.

Underground distribution is more expensive to install than the aerial lines, but leaves a smaller carbon footprint, is more reliable, and is easier to maintain.³

The two insulated service wires (to become RED and BLACK) are usually twisted around the grounded conductor as they come to the house's service head, and each feeds through a *main* circuit breaker or fuse (cartridge shaped). Afterwards, the current of both wires is divided to many individual circuits, which are individually protected by the familiar domestic round fuses or circuit breakers to



prevent damage to wiring, guard against fire, and contribute to protection against some shocks.

Pulling a fuse or opening a circuit breaker de-energizes downstream circuits, but upstream parts (the wires behind the cover panel, and leading to the fuse holder itself) are still under voltage. Circuits at 220 V are protected by double breakers, or a block of two fuses.

The home wiring system is completed by GREEN or uninsulated wires (copper color in figure) which are connected to ground (same as the WHITE conductor) in the main

³ In that case, the power is channeled from the distribution station through an array of buried cables made of a central conductor surrounded by cross-linked polyethylene and a grounded shield enclosed within a concrete slab. The transformers may be underground, but are often left above ground for economic reasons. Investment costs are significantly compensated by lower maintenance costs.

electrical box, but which are separately connected to the third contact point in the wall receptacle to serve as a metallic case grounding point for appliances.

If there is a fault of the hot (BLACK) wire to the housing, high current will flow through the grounding wire, and the *circuit breaker* will trip. While wiring plugs, the white wire should go to the silver screw, the green wire to the green screw and the black wire to the copper screw.

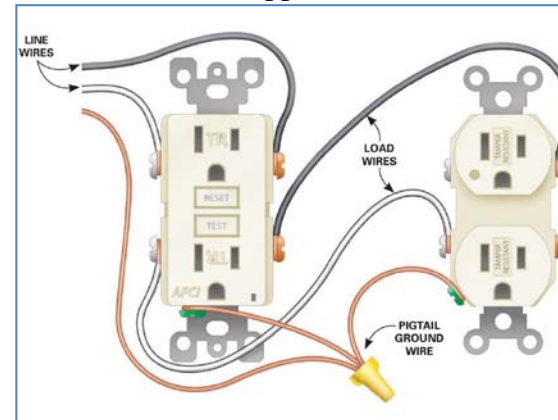

Tamper Resistant Receptacles (left) resemble regular receptacles, but provide a permanent solution to childhood shock caused by tampering with electrical outlets.



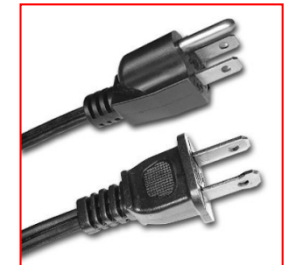





They have built-in safety shutters that block foreign objects from being inserted into the receptacle. Shutters will remain closed if an object is inserted into one side of the receptacle. The shutters open only when a 2 bladed or grounded plug (right) is inserted.



A domestic electrical outlet may present different appearances according to its position in the network (above). The wiring usually includes two insulated wires (load) plus a bare copper wire (ground).

Problem 6. Give an example of what can occur upon plugging-in if the different colors in an appliance wire are not assigned to the proper positions in the 120 V plug.

Problem 7. The proper way to verify grounding in a power tool is to confirm conductivity between:
 A - the front and rear areas of the case
 B - either the hot or the neutral prong of the plug and the ground wire prong
 C - the hot and neutral prong of the plug
 D - the case and the ground wire prong

115V, 15A		5-15P
115V, 20A		5-20P
230V, 15A		6-15P
230V, 20A	 	6-20P L6-20P
230V, 30A		6-30P
230V, 3P, 30A		L15-30P
230V, 1P, 50A		6-50P
460V, 3P, 20A		L16-20P

1.3.7. Power Metering and Smart Meters

Older analog power meters (left) were *electro-mechanical*. Power passing into the house induced voltage and current fields picked up by a special disk (CD-like) that rotated according to the power consumed. Rotations of the disk were counted by a set of 5 gears with needles. The needles could be read by a person nearby. Lifetime of these units is about 50 years. Utilities have moved from this traditional device for measuring electricity consumption once a month



for the purpose of issuing a proper monthly bill. The new opinion is that the utility can monitor the daily activities inside individual homes and businesses from readings of their detailed patterns of electricity consumption, and broadcast wirelessly those details over the air using bursts of microwave radiation,

every day, forever. To achieve this, newer electronic power or “smart” meters (right, lifetime 7 years) have microprocessors, and may also have radio transceivers. To power their electronics, they use an inexpensive switched mode power supply (SMPS) that generates some RF noise. Even if these meters had no radio transmission capability to send power consumption data to a network, they would still generate or allow passage of some electronic noise into domestic circuits. This noise could be effectively eliminated by a common mode filter (0.73\$, see figure at right), which is actually included in most other household products (Bathgate, 2017) but is rarely found in smart meters.

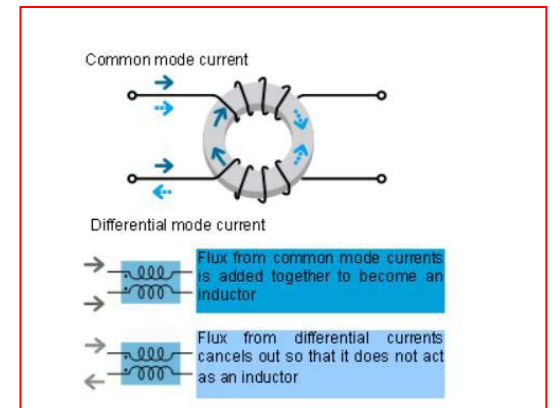

Other features of smart meters are mostly to the advantage of utilities. They allow for more “creative” billing according to time-of-day, maximum power drawn, reactive power (1.3.8 below), and, of course, bill the user for powering the meter itself: the meter is the property of the company when it comes to deciding on the meter type, but then becomes the property of the user when it comes to paying for its power consumption.

Overall, smart meters are only “smart” from the point of view of utilities, as they carry (1) risks to health from the RF radiation they generate and are inevitably (2) a risk to privacy as well as (3) cyber-security (below).

The risks to health arise from the radiation, as smart meters communicate wirelessly with the electric power companies. That radiation travels through homes and businesses readily, and penetrates the unborn, children, and adults alike. Every transmitting meter in a community irradiates everyone in that community. So does every community-based transmitter/receiver that the electric power companies have erected to communicate wirelessly with those meters. The risks to privacy arise from the capture and transmission of very highly time-resolved information about electricity consumption, which can reveal much about the activities taking place inside the homes and the businesses, sufficient, for example, to reveal when no one is there. The risks to cyber security arise from some types of meters accepting incoming wireless commands from nefarious sources. Many of those meters can respond to wireless commands to shut off the electrical power to a home or a business entirely, or to accept new software programming. That new programming can alter the functions of the meters and can do so invisibly to the owners of the homes and the businesses.

1.3.8. Reactive Power

In an alternating circuit, some current can actually slush back and forth between a device and the network, without being dissipated. The old power meters did not have the capability of detecting this, and were designed to measure consumed energy only. The new electronic meters can, and if you connect present design laptops to a network, most of the power drawn

by the power supply is actually reactive, which means that you could be billed for twice as much as

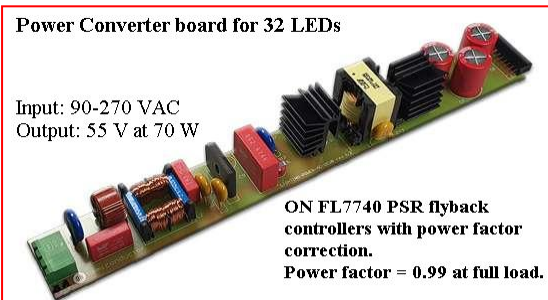

Ranking Electricity Meters for Risk

The table shows the risk rankings of electricity meters, based on a detailed analysis provided elsewhere.¹ "5" is the highest risk. Blank is the lowest risk. Capital letters separate groups of meters with similar, but not necessarily identical, risk rankings. The priorities among the different types of risk are these:

- First, the meters are arranged in descending order by Risk to Health, which the author believes to be the single most important risk factor.
- Second, the meters with the same Risk to Health are arranged in descending order by Risk to Privacy.
- Third, the meters with the same Risk to Health and the same Risk to Privacy are arranged in descending order by Risk to Cyber Security.

Meter Category	Type of Communication		Overall Risk 5 is highest. Blank is lowest.			
	Wireless	Wired	Risk to Health	Risk to Privacy	Risk to Cyber Security	
G	SMART METER	WAN/HAN	✓	5	5	5
		Bubble Up	✓	4	4	
F	Analog Meter (plus wireless digital electronics)	Wake Up	✓	4	4	
		Wake Up	✓	3	2	
E	AMR Meter	Internet cable/fiber	✓	3	2	
		Internet cable/fiber	✓	2	4	4
D	SMART METER	Telephone landline	✓	2	4	
		Telephone landline	✓	2	3	3
C	AMR Meter	None		2	1	
		None		2		
B	Basic Digital Electronic Meter	None		2		
		None				
A	Traditional Analog Meter	None				
		None				

The Wireless Smart Meter poses the highest risk in all three categories of risk. In contrast, the Traditional Analog Meter poses the lowest risk in all three categories of risk. This meter is also called the Traditional Analog Mechanical Meter with No Wireless Communications Capability.

¹ Ronald M. Powell, Ph.D., "Ranking Electricity Meters for Risk to Health, Privacy, and Cyber Security", February 12, 2015.

before, unless your device has been redesigned to bring the power factor close to 1 (I vs V phase shift).

1.3.9. Dirty Electricity

Ideally, electrical utilities provide users with pure sine wave signals that deliver power. Unfortunately, the wiring that delivers that power also acts as an antenna that carries by conduction or radiation non-60-Hz components that originate from various sources in homes or in utility equipment.

Dirty electricity is a collection of unwanted voltage signals that are added to the electrical network 60-Hz waveform by a variety of devices which need to change electrical power from ac to dc, or that generate partial electrical discharges (like the brushes of a drill). In the powering of an electronics board below, 240V AC is transformed to 24 V DC using a Switched Mode Power Supply (SMPS). In SMPS, semiconductors create high-frequency square waves, and so allow the use of a very small (light) transformer to do the voltage conversion.

Alternatively, a square waveform can be averaged to a lower voltage by a capacitor. A SMPS switches power on and off very rapidly (20 kHz to 100 kHz), but in doing so generates high-frequency electronic noise. This noise is then broadcast both through space and throughout wiring, a problem for



electro-sensitive people. Emissions of SMPSs are common with most light dimmers or LED lighting. Such dirty electricity can be generated by devices inside a home, but also be carried by a power network connection into a home. It can be



conveniently monitored using a small AM radio receiver tuned off-station, as switching transients are rich enough in frequency components to

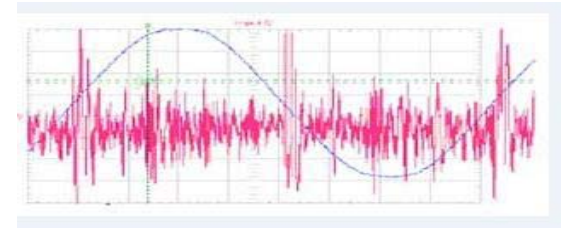

reach the AM band. The static noise from the radio will increase when nearing a device that generates dirty electricity. Since local reception minimal signals for AM are 2 mV/m ($0.01 \mu\text{W}/\text{m}^2$), sensitivity of even a small radio is better than what is needed for health protection.

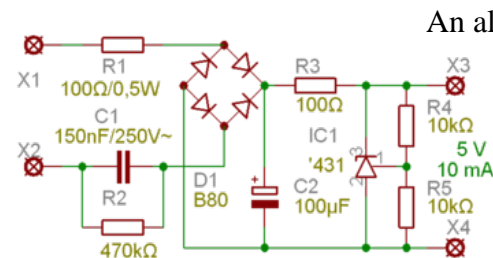

An alternative method to lower voltages for small power applications only (since high voltage capacitors like C1 are expensive and bulky) is the capacitive power supply. But it

delivers relatively little dc power compared to the ac power drawn from the ac supply. In the diagram, capacitor C1 limits the current flowing through the rectifier bridge D1. R1, connected in series, protects against voltage spikes during switching operations. C2 smooths the DC voltage and the peak current (in the range of amps) in switching operations. R3 and IC1 smooth the voltage.

For more information on power supply designs, see PHH23:\Electromagnetism\Readings\
1 - Lu, Bing. TI Introduction to EMI in Power System Designs.pdf

1.3.10. Power Filtering



Very few devices use ac power, so we have witnessed the appearance of many small external power supplies (left) transforming ac into dc, some of them noisy. Filtering such power sources can be done most economically using passive elements like inductors (L , that

prevent the noise from escaping) and capacitors (C , that drive noise to ground) as shown here. Noise from power sources can also be attenuated using ferrite beads (5.4.11).

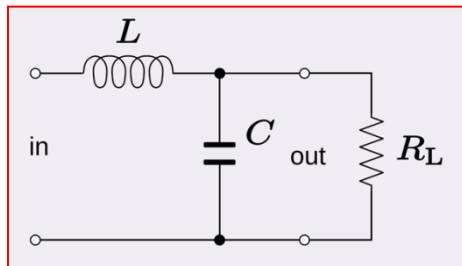

1.3.11. Power over Internet (PoE)

To minimize wire encumbrance from data devices, the Power over Ethernet (PoE) standard allows standard Ethernet cables

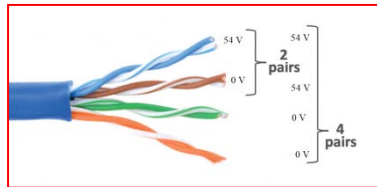

to carry up to 90 W of power, allowing almost any Ethernet device to be powered by a single

Ethernet cable. Inside



the Ethernet cable itself are four twisted wire pairs, and each twisted pair connects to a LAN transformer. PoE injects a dc voltage (~ 54 V) onto 2 or 4 of the twisted pairs of the Ethernet cable through center taps on the transformers. The powering device sends a series of pulses to determine and manage the power needs of the downstream device.

	Type 1 802.3af			Type 2 802.3at	Type 3 802.3bt		Type 4 802.3bt	
Power Class	Class 1	Class 2	Class 3	Class 4	Class 5	Class 6	Class 7	Class 8
Power from PSE	4 W	7 W	15.4 W	30 W	45 W	60 W	75 W	90 W
Power delivered to PD	3.84 W	6.49 W	13 W	25.5 W	40 W	51 W	62 W	71.3 W

1.3.12. Telephone Network

Telephone systems use 48 V dc for voice, with a ringing signal of up to 130 V_{rms} at about 20 Hz, but limited to 50 mA (20 Hz is less hazardous than 60 Hz). *It appears that the telephone system's electric design has never resulted in fatalities.*

1.3.13. Industrial

Because some industries are heavy consumers of electricity, it is often economical to bring *power near a plant at a relatively high voltage level*, to minimize the metal costs. Most industries consuming large powers have small **substations** (i.e., transformers plus associated switching hardware) adjoining to, or within their walls to transform the relatively high voltages at that point to lower ones.

Even within the plants, a distribution system at higher voltages is often used, again to keep metal costs down. 230, 460, 600 V systems are used for heavy tools and machinery.

Each of these voltages levels has a set of *standardized plugs, insulations and circuit breakers*, together with specific current ratings.

1.3.13.1. Switches

Switches in industry often have to *interrupt substantial powers, and it is a potentially dangerous situation to open a switch under load*. The units are likely to be enclosed in a *metallic housing* which is carefully grounded, and contains large metallic contacts, sturdy enough not to deteriorate under

powerful arcs. Insulating plates are sometimes added near the contacts.



Industrial Switch Box.



A 3-phase SF6 switch used in electrical utility distribution.

1.3.13.2. Circuit Breakers

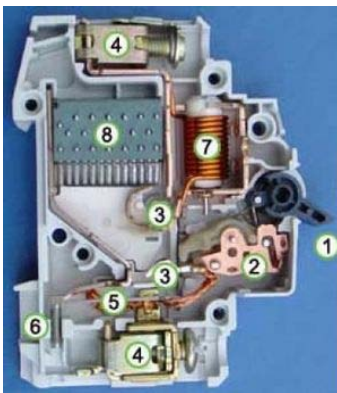

Circuit breakers throw automatically when a current level is exceeded. The most common domestic units use the magnetic force of a coil to throw a latch.

1. Actuator lever.
2. Actuator mechanism.
3. Contacts.
4. Terminals.
5. Bimetallic strip.
6. Calibration screw.
7. Solenoid.
8. Arc divider-extinguisher.

Industrial breakers are sealed units containing *oil* or SF₆. SF₆ is a stronger dielectric than air, and therefore allows a more compact design.

Problem 8. What property of oil makes it useful in circuit breakers?



Under substantial (industrial) power levels, the *extinction of electric arcs* may present severe problems and safety risks. As was mentioned in the section 1.2.7, interruption of high power inductive loads can be dangerous if a human operator is in the vicinity of the electric arc. However, when the power is high enough, even resistive load interruption is dangerous. This arises because there is not enough time between two voltage crests

(1/120th of a second at 60-Hz) *to cool down the plasma* in the arc to a temperature low enough to de-ionize the air, and re-establish **insulation levels**. Further, in an electrical network, an arc establishing a fault to ground at one location will monopolize energy from all sources it is connected to, thereby passing **very large currents**. The large, hot arcs are therefore difficult to extinguish (the best example of this is the high voltage network of power utilities).

1.3.13.3. Fuses

Fuses are metallic links that melt or vaporize under excessive heat. The fusible link may be surrounded by sand to help dissipate the electric arc, which is inevitably formed when the metal melts. In order to allow operation of switches in complete safety, both remotely activated



(“control circuits” consisting of a switch activated by an electrical motor) and manual switches are often provided in series on the same circuit, when large loads are involved.

The role of switches, breakers and fuses can hardly be overplayed in electrical safety. They are comparable to a car’s brakes in road safety. They are the devices which allow interruption of flowing currents in emergency situations.

Ideally, however, manual switches should be able to interrupt the full **short circuit current** that a circuit is able to supply, while maintaining operator safety. But in some cases, manual switches may be designed to be operated under NO LOAD conditions, and are actually there to guard against any accidental power-up of a disabled circuit (but not to interrupt its operation): although the manual switch may not be capable, on opening, of interrupting the flowing current, it will not allow it to start flowing if it is already open, even if the control circuit is enabled. It should also be emphasized that every switch has a rated interruption capacity, generally specified in amperes within a given voltage range.

Therefore, scenarios in which manual switches are operated on defective apparatus in short-circuit (passing very high currents) are notably dangerous, and the cause of many grave industrial accidents.

Problem 9. Before interrupting the power to a large industrial motor with a manual blade switch, the electric switch controls should be locked off and tagged to:

- A - discharge any potential energy in the system
- B - avoid an improbable switch failure
- C - avoid operating the manual blade switch under a load condition
- D - maintain safety during a shift change

Problem 10. The totally safe way to lock out a large motor if a high risk of accident exists is:

- A - to tag every remote operator station in the off position
- B - to lock out the local ON-OFF switch
- C - to deactivate the electrical control circuit
- D - to interrupt the circuit power leads at the motor

Problem 11. Why is it safest to check that there is no power on the load side of a switch after opening it?

Problem 12. The proper way to put a motor back into service is:

- A - put the manual switch in the ON position before taking lock and tag off the control circuit
- B - re-energize the manual switch after you take your lock or tag off the control circuit
- C - re-energize all interlocked control circuits before re-energizing the manual switch
- D - re-energize the control circuit exactly as the manual switch is thrown

1.3.14. Why 60 Hz?

The selection of a power network frequency is a result of several compromises.

- Alternating current is used so that transformers can be incorporated into the network. Transmission of electric power being more economical at high voltages, transformers are convenient devices **to step down or up the voltage levels** to values compatible with domestic or industrial use, with *little energy loss*.
- The frequency of operation should not be too low.
 - The reason for this is that *the lower the frequency, the more magnetic material is required* in a transformer to handle a given amount of power. As the frequency is lowered from 60 to 50 Hz, for example, the magnetic core must contain

correspondingly more metal mass to avoid *magnetic saturation*. Therefore, as the frequency decreases, transformers cost correspondingly more.

During solar storms, when plasma from the sun hits the Earth, changes in the static magnetic field as high as -850 nT can cause transformer saturation, and province-wide power failures, such as in Québec in March of 1989.

- In the rectification of ac power to a filtered, controlled dc level (which is required in many practical applications, such as in electronics), a very low frequency would require *excessively large capacitors* to obtain a regulated dc level.
- The frequency of operation should not be too high.
- The *energy losses* in transformers generally increase with the *square of the frequency*⁴.
- The alternators powered by hydraulic turbines cannot be built to achieve unlimitedly *high rotational frequencies*, because of practical mechanical problems.
- High frequencies would mean a **waste of conductor metal** because of the *skin effect* (*the skin effect is the tendency for high frequency currents to circulate predominantly at the surface of solid conductors*).
- High frequencies would mean more *electrostatic and electromagnetic induction* (power losses and shock hazards).

⁴ The compromise may lead to different decisions. In airplanes, for example, where the weight of the transformers is of paramount importance, while the power loss is somewhat secondary, higher frequencies are usually employed (400 Hz).

Most countries of the world outside North America use 50 rather than 60 Hz. Two countries, Japan and Saudi Arabia, are divided between the two frequencies.

1.3.15. Why 3-phase systems?

Power networks use three phases for mechanical reasons. According to the principles of *electromagnetic induction*, an **electromotive force is induced in a coil in proportion to the variation in magnetic flux** within it. In the case of a rotating machine such as a motor, the induced electromotive force varies as a *sine wave over a complete rotation*, and so does the mechanical force. In the figure below, the effort is maximal at the points of rotation illustrated.

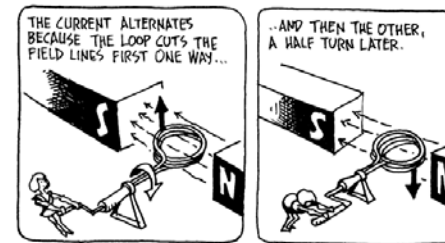

Gonick, 1990

This oscillation in force tends to induce vibrations at the rotation frequency.

If 2 supplementary windings, each lagging 120 degrees or 5.55 msec (that is, 1/60 sec divided by 3) from the reference coil, are introduced, the regularity of the effort over a complete rotation is perfect, because the 3 phases add up to a constant effective force over every portion of the cycle (high-powered motors often use 3 phases).

As these three phases are synchronized, but offset in time, they must be transported on different wires.

Virtually all transmission towers present 3 live conductors, and sometimes two sets of 3 wires (double circuit is shown at right).

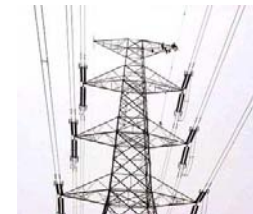

At the point of power consumption, loads can be connected *phase-to-ground* (the earth is a convenient return path for the current), or *phase-to-phase*. When power consumption on the 3 phases is equal, the return currents cancel out exactly, and no ground return occurs. In a balanced 3-phase system, the total power is three times that available from any single phase, and the voltage between two phases is related to the voltage between one phase and the ground according to:

$$V_{\phi-\phi} = \sqrt{3} V_{\phi-\text{ground}} = 1.732 V_{\phi-\text{ground}}$$

Residential power tends to be single-phase, whereas industrial power is usually three-phase, with perhaps a neutral return.

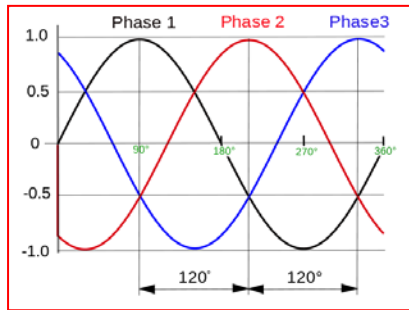

3-phase underground cable.

1.3.16. Why not DC systems?

The “war of currents” in the late 1880s between Edison and Tesla-Westinghouse on the deployment of dc or ac systems was won by ac (ac electrification of Rome in 1886), based on the practicality of the transformer as a power-handling device. However, as we shall see in later chapters, ac EMFs have health effects on living systems. Such effects could be eliminated by dc transmission, distribution and consumption of electric power. Although small networks using dc power have survived until now, the world has been mostly taken over by ac networks.

But dc high power transmission lines have recently become popular for interconnections between power grids. They allow more transmission over a given right-of-way, better control of power flows in transient and emergency situations, and improve reliability.

Computer data centers would save 7 to 8% in energy by eliminating multiple stages of conventional AC power distribution, as well as air-conditioning for heat dissipation. These would best be served by dc power with a dc split +190 and -190 V feed. 380 volts is compatible with the typical ratings of components now used in computer power supplies. The inverter output stages of UPS are presently the source of many data center failures. The 380 V dc network could be directly connected to batteries to provide uninterruptible power.

Very few electrical loads need ac power, as most applications, including heating, computing and motors, are native dc applications. Transformers would be replaced by semiconductor switching components such as thyristor and field-effect transistors for changing voltage levels. Capacitors are charged in series and discharged in parallel to reduce voltage and increase current.

A dc grid deployment in the future would reduce global energy consumption by 20%. As dc sources are easily paralleled, a dc network would allow easier compatibility of electrical network of all sizes: eliminating *stability* problems for power utilities, and helping compatibility of utilities with small distributed suppliers of wind and solar energy. This would make the power grid more democratic, reliable and green. People with electric cars could easily use them in case of grid power failures.

The capacity of present power lines would increase without cost by 30% due to the fact that voltage is maximum 100% of

the time on a dc network, and to the elimination of the *skin effect*.

Corrosion of metallic structures (pipelines, steel reinforced concrete) by induced currents would be reduced or eliminated. It would allow signal cables to double as power cables, as in PoE, reducing the number of wiring connections.

The clean electromagnetic environment provided by a dc power system would facilitate the development of therapeutic applications based on electro-magnetic fields.

The need to power LED lighting and other dc loads has resulted in the introduction of dc line voltages in commercial and residential buildings, usually 24 V dc. These require a dc-dc converter, which is a type of *switching* voltage regulator. Power plants and industrial installations often use high-voltage dc, typically 120 to 330 V dc, since they can't always depend on outside ac power. This dc voltage is frequently backed up with batteries.

1.4. Summary

Electricity is a flexible form of energy described by variables known as Volt, Ampere, Watt (or Volt-Ampere), Ohm and Joule. Capacitors and inductances are special electrical elements with important technical applications, and the ability to shift the phase of alternating currents. 60-Hz power networks use transformers to transfer power from transmission voltage levels to distribution levels. The interruption of electricity is achieved by fuses and circuit breakers, which provide a major component of electrical safety.

The grounding configuration of electrical networks has ignored both safety aspects of magnetic field exposures as well as earth's electrical contamination by grounding practices.

1.5. Bibliography

- Bathgate W, 2017.** Evaluation of the ITRON Open Way AMI Meter. <http://www.stopsmartmetersbc.com/wp-content/uploads/2017/02/Evaluation-of-the-ITRON-Open-Way-AMI-Meter-PowerPoint-by-William-S.-Bathgate-Jan.12-2017-.pdf>
- Bawin SM, Gavalas-Midici R and Adey WR.** Effects of electric fields on specific brain rhythms. Symposium and workshop on the effects of low frequency magnetic and electric fields on biological communications processes. 6th annual meeting, Neuroelectric Society. Vol. 6, 1973.
- Burke, J J.** 1991. "Controlling Magnetic Fields in the Distribution System". Transmission & Distribution. 43:12, pp 24-27, Dec. 1991
- Cope, FW.** A dinetic theory of electron and ion conduction through enzymatic particles, with applications to the cytochrome oxidase, melanin free radical and pyruvate carboxylase reactions, and to control of enzymes by hormones and radiation. In: King TE, Mason HS and Morrison M (eds): Oxidases and related redox systems. New York, Wiley & Sons, 1965, p. 51.
- Dahlberg DA.,** Ground Currents. <https://www.sandiegocounty.gov/content/dam/sdc/dplu/ceqa/Soitec-Documents/Record-Documents/Undated-Duane-A-Dahlberg-Report-re-Ground-Currents-An-Important-Factor-in-Electromagnetic-Exposure.pdf>
- Dahlberg D and Laurence Falk.** 1995. Electromagnetics Ecology: Stray Voltage in the Dairy Industry. The Electromagnetics Research Foundation, Inc. January 1995.
- Gonen T.** 1986. Electric Power Distribution System Engineering. Hightown, NY: McGraw Hill.
- Hartsell DI, Duane Dahlberg, Dave Lusty, and Robert Scott.** 1994. "The Effects of Ground Currents on Dairy Cows: A Case Study".The Bovine Practitioner. September 1994. p 71-78.
- Hendrickson RC, Mike Michaud and Alvin Bierbaum.** 1995. Survey to Determine the Age and Condition of Electric Distribution Facilities in Minnesota: Report 1: Analysis of Overhead Distribution Feeder Testing Data. Minnesota Public Utilities Commission. May 18, 1995.
- Lu B.** TI Introduction to EMI in Power Supply Designs. Texas Instruments High Voltage Seminar, 2021. <https://training.ti.com/introduction-emi-power-supply-designs>
- Mairs D.** 1994. "Overview of Distribution Systems". Team of Science Advisors Meeting. Minnesota Public Utilities Commission. Radisson Hotel. St. Paul, MN. December 12-13, 1994.
- Marks TA, C. C. Ratke, W. O. English.** 1995. Veterinary and Human Toxicology. 37:2. p 163-172.

Morrison C. 1963. "A Linear Approach to the Problem of Planning New Feed Through Points Into a Distribution System." AIEE Trans. III.(PAS) Dec. 1963 p 819-832.

Nordenstrom B. 1983. "Biological Closed Electric Circuits: Clinical, Experimental, and Theoretical Evidence for an Additional Circulatory System." Stockholm: Nordenstrom.

Ontario Bill 161, 2016. <https://www.ola.org/en/legislative-business/bills/parliament-41/session-1/bill-161>

Preston EG, P.E. 1989. "EMF EFFECTS FROM URD SYSTEMS". presented at American Public Power Association Engineering & Operations Workshop, Washington, D.C. March 15, 1989.

Raloff J. 1993. "EMFs Run Aground". Science News. 144, pp 124-127, 1993.

Rosenberg B. 1965. Some problems in the electrical conductivity of proteins. In: King TE, Mason HS and Morrison M (eds): Oxidases and related redox systems. New York, Wiley & Sons, 1965, p. 72.

Trukhan EM. Determination of the mobility of charge free carriers in biological combinations. Biofizika 11:412, 1966.

Zipse DW. 2003 The Hazardous Multigrounded Neutral Distribution System and Dangerous Stray Currents. IEEE Industry Applications Society 50th Annual Petroleum and Chemical Industry Conference, 2003. Record of Conference Papers. DOI: 10.1109/PCICON.2003.1242596
https://www.ecs.csun.edu/~bruno/MultiGroundedNeutralFinal_4-17-7.pdf

2. ELECTRIC CONTACT AND SAFETY PROCEDURES.. 2

2.1. Electric Contact	2
2.1.1. Protection	2
2.1.2. Electric Shock Risks	3
2.1.3. 60-Hz Shock Thresholds	4
2.1.4. Step and Touch Voltages.....	5
2.1.5. Ventricular Fibrillation.....	6
2.1.6. Heart Physiology	6
2.1.6.1. Electrocardiogram	8
2.1.6.2. Fibrillation threshold: duration and energy of shock.....	11
2.1.6.3. Defibrillation	12
2.1.6.4. Defibrillation Devices	13
2.1.6.5. Manual and Automatic Defibrillators	13
2.1.6.6. Pacemaker implantation	13
2.1.7. Epidemiology of Electrical Accidents.....	14
2.1.7.1. Deaths.....	14
2.1.7.2. Work Injuries.....	15
2.1.8. Electrical Burns	16
2.1.8.1. Surgical Aspects of Electrical Burns Treatment.....	16
2.1.8.1. Neurological and other sequelae.....	18
2.2. Electrical Safety Procedures.....	19
2.2.1. Legal Guidelines	19
2.2.1.1. Origin of Rulings.....	19
2.2.1.2. Rate of Safety Rules Violations in the Workplace	19
2.2.1.3. Infractions involving Grounding Connections	20
2.2.1.4. Infractions involving Dielectric Insulation.....	21
2.2.1.5. Infractions involving Current Capacity	21
2.2.2. Safety at Home.....	21
2.2.2.1. Fuses and Breakers	21
2.2.2.2. Casing Grounding.....	22
2.2.2.3. Double Insulation	22
2.2.2.4. Ground Fault Circuit Interrupter	23
2.2.2.5. Water Risks	24
2.2.3. Safety in Industry	24
2.2.3.1. Door Interlock	24
2.2.3.2. Padlocking (lockout)	25
2.2.4. Safety in Power Networks.....	26
2.2.4.1. Transmission Network Maintenance	26

2.2.4.2. Distribution Network Maintenance.....	27
2.2.5. General Safety Procedures	27
2.2.5.1. Equipment.....	28
2.2.5.2. Labeling	28
2.2.5.3. Awareness of Specific Dangers	28
2.2.5.4. Specific Work Procedures	28
2.2.5.5. Arc-Flash	29
2.2.6. Fires due to Electricity.....	29
2.2.7. Explosions due to Electricity.....	30
2.2.7.1. Area and Material Classification	30
2.2.7.2. Electrical Triggering of Explosions	31
2.2.7.3. Prevention: Intrinsically Safe Wiring	32
2.2.7.4. Limiting Explosions using Special Housings	33
2.2.7.5. Explosion-Proofing.....	33
2.2.7.6. Pressurization.....	33
2.2.7.7. Anti-Static Coatings.....	34
2.2.8. Safety in Special Environments.....	34
2.2.8.1. Mines	34
2.2.8.2. Grain Elevators	35
2.2.8.3. Offshore Rigs.....	36
2.2.8.4. Welding	36
2.3. Summary	36
2.4. Bibliography.....	37

2. ELECTRIC CONTACT AND SAFETY PROCEDURES

2.1. Electric Contact



2.1.1. Protection

Electric contact with the human body can result in fatal or non-fatal electric shock. Electrical accident avoidance is based on two principles.

A - Avoiding contact with conductors under voltage.

This is done using electrically insulating barriers: air, plastics.

B - Detection of faults by the electrical circuits themselves.

This is done by using engineering techniques of fault detection, such as fuses, circuit breakers and ground fault circuit interrupters.

One must remember that *fuses* and *circuit breakers* are designed to **protect equipment, rather than people**.

Fuses have:

1. a maximum voltage rating,
2. a maximum current rating and
3. a current interruption rating.

The maximum voltage rating protects against air breakdown in or around the unit.

The maximum current is the current value at which the *fusible* element, usually a soft metal, melts.

The current *interruption* rating is the maximum arc current that the fuse, once melted, is able to interrupt by virtue of its cooling capacity.

Problem 13. Compared to the old fuse it is replacing:

A - the new fuse has equal or higher voltage and current interruption ratings

B - the new fuse has exactly the same voltage and current interruption ratings

C - the new fuse has equal or lower voltage and equal or higher current ratings

D- the new fuse has equal or higher voltage and equal or lower current ratings

Where a human is energized by a hot conductor, there *must be* a second (grounded) body contact for current to flow, and for a shock risk to develop.

It is true that the practice of grounding all metallic enclosures increases the number of such grounding points, thus increasing the likelihood of shock. But it is accepted that the practice of grounding metallic surfaces reduces risks nevertheless, because properly wired electrical enclosures will detect failures before contact with a human occurs, and interrupt power automatically [Bernstein, 1983; Squillace, 1989].

2.1.2. Electric Shock Risks

Death from electric shock results from:

- 1 - **ventricular fibrillation,**
- 2 - **respiratory inhibition**
(death by suffocation),
- 3 - **burns** from passage of electricity through tissues, or from contact with electric arcs,
- 4 - **secondary effects due to loss of control** (ex., falls),
- 5 - **fire** (use Class C extinguisher) or
- 6 - **explosions** triggered by electric sparks.

Wounds of various severities can also result.

Material losses can also occur: shocks can *ignite flammable materials*, and may destroy or induce improper working of electronic safety equipment. This last may be of more consequence as *more and more safety measures depend upon electronics*. Critical devices such as pacemakers must be specially designed to resist currents and fields applied to or around the body.

Electrical contact hazards are eliminated by **prevention of contact** and by **grounding** surfaces where contact is possible. A conductive surface is “grounded” by a metallic path (green wire, continuously metallic water pipe without plastic joints, etc) connected to the earth and providing a resistance low enough that the fuse or breaker will interrupt the power in the event of a fault, according to their electric current rating.

A grounded enclosure should not be at a potential greater than 30 V, even in the event of a fault, and should not be able to deliver a current greater than 5 mA.

Physiological effects of electric currents are dependent on the **frequency** of the voltage applied. DC and 10,000 Hz currents, for example, have thresholds of perception and paralysis about 5 times higher than 60 Hz. Fibrillation currents at 0 and 10,000 Hz are 130% of the 60 Hz value at, and below, 0.1 second of duration. With DC, letting-go of parts gripped is less difficult, and for shock durations longer than the cardiac cycle, the fibrillation thresholds are considerably higher than for AC currents. This is because the effects of currents on the body are in great part mediated by the charge delivered to cell membranes, facilitated by higher frequencies. Consequently, fatal accidents with DC occur only in very unfavorable conditions (mines).

In nature, electric shocks can be delivered by lightning associated with storms. 24,000 people are killed by lightning strikes around the world each year, and men in the US are struck 6 times more frequently than women.

Apart from the less frequent DC shocks, electric shocks delivered to humans can be of two basic types:

- transient switching surges (electrostatic shocks, etc) and
- 60-Hz waves.

The two may occur on the same occasion. Because the transient shocks are more diverse, their study is more difficult.

Transient Shock Example

Electric fences for cattle use pulses trains of 10 to 20 kV with a maximum current of 5 mA, at approximately one pulse per second. One can infer from this design that substantial and unpleasant nervous stimulation can be obtained by brief high voltages, but with small health (fibrillation) risks.

2.1.3. 60-Hz Shock Thresholds

Three threshold levels are considered: **perception**, **let-go** (maximum level at which the subject can release his grasp) and **lethal** (from fibrillation). All are defined in terms of **current** passed through the body [Dalziel, 1941, 1972; Electric Shock Safety Criteria, 1985].

Problem 14. An engineer from an industrial plant has to build a short 60 Hz electric line to bring power from one building to another but crossing above a location where there is public access as well as metallic objects insulated from ground. He consults you on the level of induction current allowed. He read that the fibrillation current is 150 mA and proposes to dimension his installation accordingly. What would you tell him?

It was discovered in 1933 that above approximately 4 A, the depolarization of heart muscle by the 60 Hz current is sufficiently powerful that upon interruption of the current, the heart will pause for a few seconds, and then start a normal beat on its own accord.

The phenomenon of fibrillation therefore occurs in a window of currents, rather than above a certain value.

This amplitude window is reflected in the figure at right, showing the probability of shocks being fatal as a function of system voltage. There is an increase up to 4 kV, reflecting a higher probability of attaining fibrillation current. After that, **defibrillation** sets in, with the slowly rising lethality at high voltages caused by burn wounds [Hotte, 1990].

The **perception current** is ~ **1 mA**.
in a hand grip to an energized metal cylinder.

The **let go currents**
for men, women and children are
~ **15, 10 and 5 mA**.

Thoracic tetanization
is ~ **20 mA** in adults.

Fibrillation currents are
~ **150 mA** for adults and
30 mA for children.

Absolutely safe thresholds for
men, women and children are
9, 6, and 4.5 mA.

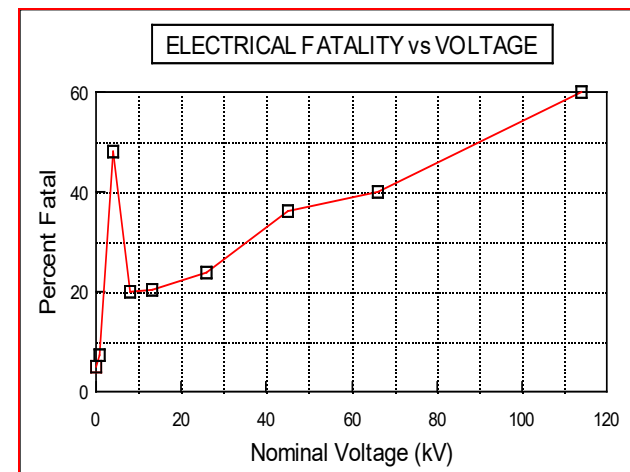

The *threshold values* above are given in units of *current*.

A resistance value of $1000\ \Omega$ is most often used as representative of the impedance of the human body, in practical situations [Bridges, 1981].

However, the current through to the human body in accident scenarios depends on the voltage applied, and on the total circuit resistance. This is the sum of the

- (1) external circuit resistance,
- (2) body resistance and
- (3) contact resistance.

The *contact resistance* depends on

- (1) the area of the skin in contact with the electrode,
- (2) the moisture content of the skin, and
- (3) the applied pressure.

The effective values for the contact resistance are highly variable, and this is the primary reason why there is considerable dispersion in the severity of accidents in a given configuration.

2.1.4. Step and Touch Voltages

Two situations are often referred to in the literature dealing with electric shocks, the “**step**” and “**touch**” voltages.

In the “**step**” voltage (left, in the figure), the hypothesis is made that a standing worker is subjected to a potential applied *from one leg to the other* caused by intense circulation of current through the ground. Current of this magnitude can

occur as a result of **lightning strike, or flashover fault** of an electrical network.

In the “**touch**” potential (right, in the figure), assumption is made that the *worker’s hand* comes into contact with a metallic structure which delivers a shock current from the upper extremity to the subject’s two grounded legs.

Such potentials can result from a wide range of scenarios including *electromagnetic induction*. “Touch” potential accidents are more frequent than “step” potential accidents.

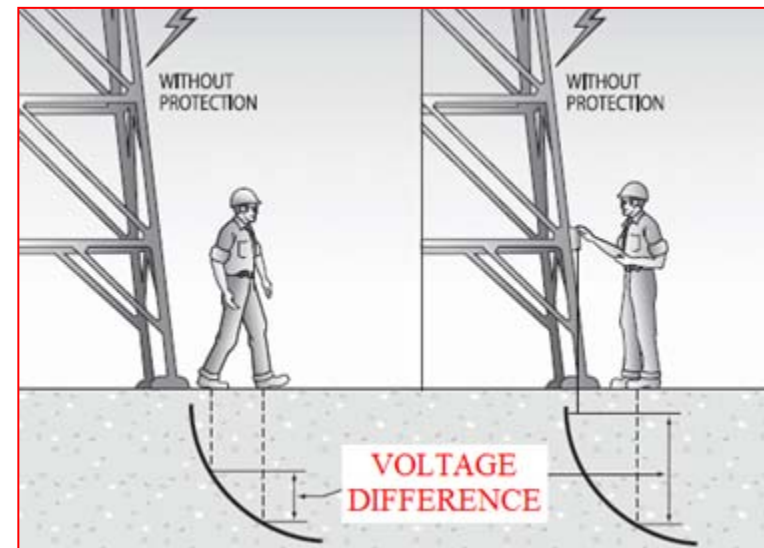

Another rather frequent configuration among workers is the **hand-to-hand shock**. Often, a metallic tool is energized, and the worker contacts a grounded conductor with the other hand, or vice-versa. This type of accident actually has a higher fibrillation threshold (by a factor of approximately 2) than most other paths (see the Heart Current Factors in the table below, which rate the proportion of the injected current effectively stimulating the heart).

CURRENT PATH		HEART CURRENT FACTOR
FROM	TO	
Chest	left hand	1.5
Chest	right hand	1.3
Left hand	left foot	1.0
	right foot	
	both feet	
Both hands	both feet	
Right hand	right foot	0.8
	left foot	
	both feet	
Back	left hand	0.7
Seat	left hand	0.7
	right hand	
	both hands	
Left hand	right hand	0.4
Back	right hand	0.3

Linesman under 230 V

A 21-year old linesman, working outdoors in hobnailed boots, was standing on wet dewy soil, and grasped a copper wire in contact with a live conductor at 230 V with the right hand. He could not let go, and felt his right arm tightening, and then his chest. He later stated that he was losing consciousness when he was rescued. His colleagues said he was going blue. They applied artificial respiration on him at once, and he was taken to a medical unit. He felt shaky for half an hour and rested for the remainder of the day. For a week after, he felt a stiffness in his neck and chest, as though he had had unaccustomed exercise.

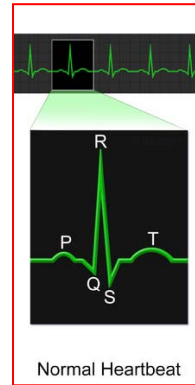

2.1.5. Ventricular Fibrillation

Ventricular fibrillation is the most dramatic risk associated with passage of electrical current through the body. Once fibrillation sets in, spontaneous remission is almost unknown.

2.1.6. Heart Physiology

In nerve or skeletal muscle, each cell responds individually, so that only cells exposed to supra-threshold excitation are stimulated. Also, each muscle fiber depends on the nervous system to trigger contractions.

By contrast, within the heart muscle, excitation generated anywhere is propagated to all cells of the heart.

Myocardial fibers are capable of propagating the **action potentials** of the heartbeat without attenuation, due to the intercalated disks present at cell boundaries, and to the inclusion of macrophages in heart tissue [Hulsmans, 2017].

To trigger and supplement this spontaneous propagation of *action potentials*, the heart has a specialized, autonomous¹, electric stimulation system.

While the myocardium contracts, its cells are in a transient phase of membrane depolarization, as depicted in the following figure. The top panel shows a typical depolarization wave, as

¹ The muscle cell's capacity for spontaneous excitation is more a *primitive* than a highly specialized function of myocardial tissue. In the early embryonic stage, all cells in the *heart primordium* are spontaneously active. As *differentiation* proceeds, most of the fibers of the myocardium give up auto-rhythmicity and develop a stable, high resting potential. The stability of this resting potential can be lost in various "pathological" states associated with an increase in the membrane's Na⁺ conductance.

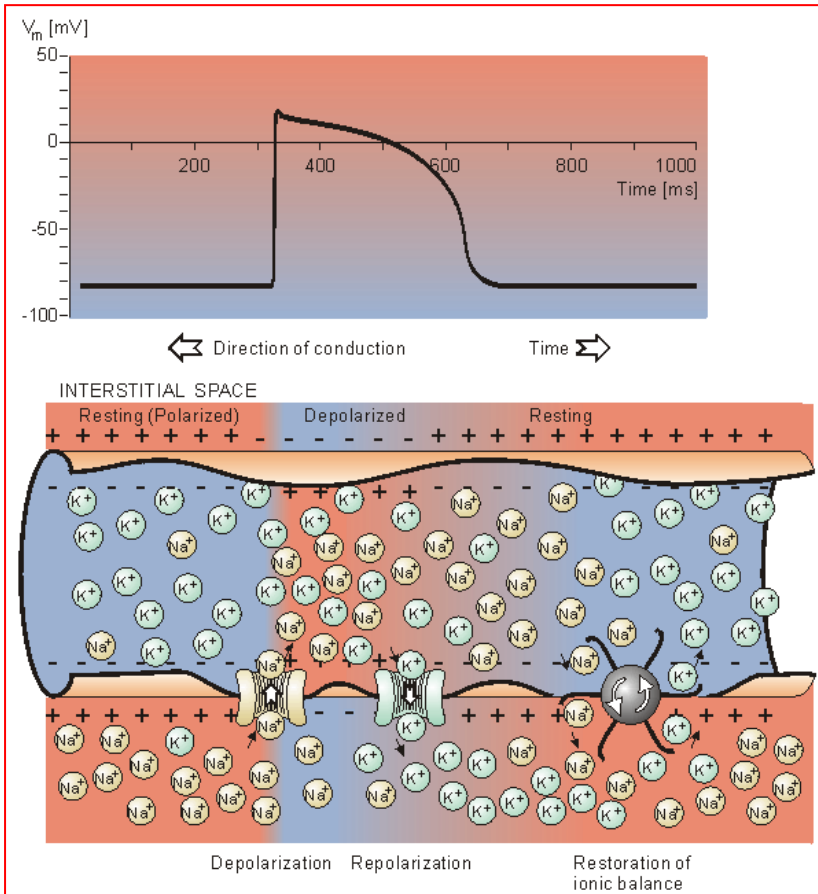

measured across the myocardium cell membrane, while the bottom panel displays the corresponding ionic events. Under suitable conditions, a heart removed from the body will continue to beat at a constant frequency, a property called *auto-rhythmicity*.²

² This phenomenon led to very specific religious rites among the pre-Columbian civilizations of America.

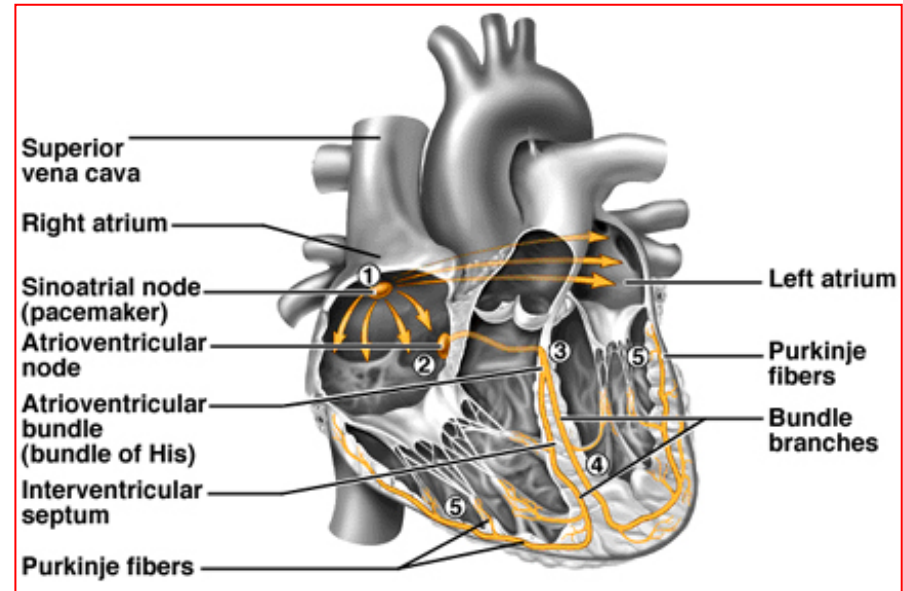

The arrangement of the *pacemaker and conducting system* of the heart, in frontal section.

The heartbeat is initiated (1 in the figure above) in the *sinoatrial node* (~70 impulses per minute). As the wave of depolarization reaches (2) the *atrio-ventricular node*, it is briefly delayed, but thereafter propagates through the bundle of His (3) and the Purkinje fibers (4-5) at **twice the speed which is normal for ventricular musculature, 1 m/s**. The *specialized system of conduction and the normal propagation properties of the myocardium therefore combine to provide the normal beat of the heart*.

Cardiac musculature shares with other excitable tissues a *reduced responsiveness to added stimuli* occurring later than the main excitatory process. The terms **absolute and relative**

refractory periods are used for phases of *abolished* and *diminished* responsiveness.

The figure at right [Antoni, 1983] shows how these periods relate to the action potential of the heartbeat. The refractory period is related to inactivation of the initial mechanism of cell excitation, opening of the Na⁺ gates, which allows intracellular penetration of Na⁺. Because the *refractory period of the excited myocardial cells is normally longer than the time taken for the spread of excitation over the atria and ventricles*, the wave of excitation **dies out**, since it **encounters refractory tissue everywhere**. The refractory mechanism is responsible for eliminating the possibility of tetanic contraction of the heart, a situation which would be incompatible with the heart's function as a pump. Tetanizability is, by contrast, a property exhibited by all skeletal muscle.³

Contraction of the heart is dependent on a synchronized depolarization wave. A myocardium lesion which retards depolarization waves increases the risk of fibrillation.

An external electric current stimulus also disrupts the normal pattern of depolarization, and the risk of fibrillation is also increased, providing the **first** means of external fibrillation.

³ Skeletal muscle cannot be repeatedly stimulated without fatigue, in part because it derives energy from a different metabolic pathway; it gets tired and needs a rest. However, if skeletal muscle is steadily stimulated for several weeks, it undergoes dramatic structural and biochemical changes that leaves it remarkably like cardiac muscle. In fact, if the pattern of electrical stimulation is adapted into a series of eight heart-like stimuli in rapid succession, a cardiac-like contraction is obtained. In a recent surgical application, people with heart problems can be aided by their own *latissimus dorsi* (muscle from under the arm to the middle lower back) wrapped around their damaged heart, and stimulated with a special pacemaker.

2.1.6.1. Electrocardiogram

As excitation spreads over the heart, an electrical field is produced which can be sensed on the surface of the body as the **electrocardiogram**. On the next page is illustrated the details of

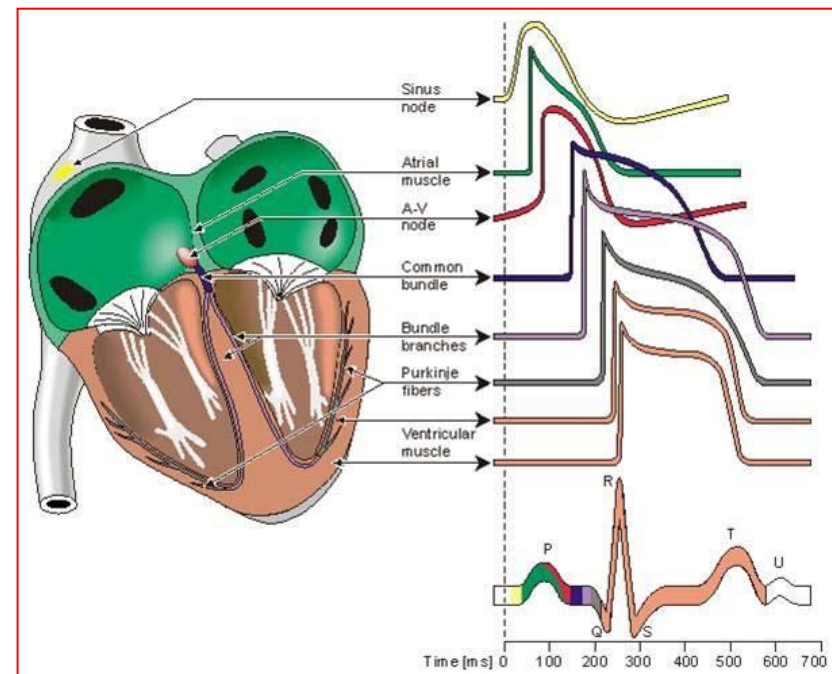
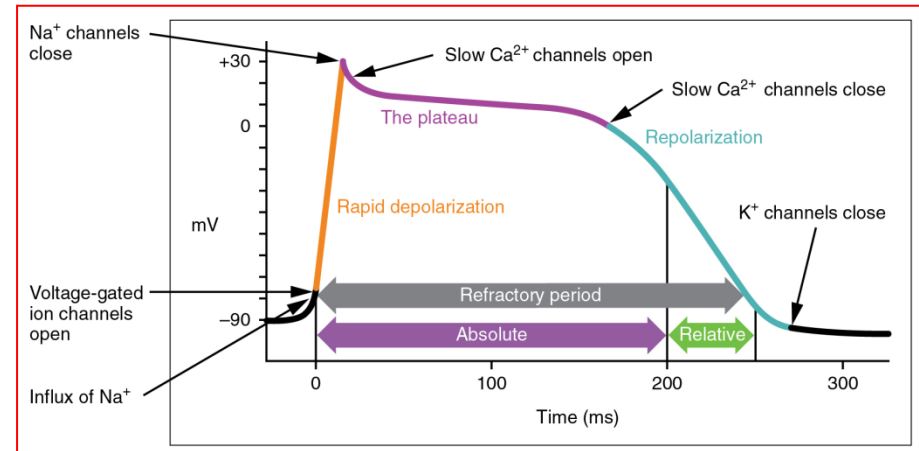

the *vulnerable period* [Geddes, 1985] for electrical stimulation.

Generally, the P wave represents depolarization (contraction) of the atria (green in the figure above).

Repolarization of the atria is invisible, masked by the QRS complex.

The cycle of contraction of the ventricles (pink in the figure above) starts with the Q wave. The QRS complex represents the spread of excitation over both ventricles. The ST segment indicates total excitation.

The T wave is the repolarization of the ventricles, recovery from excitation in the ventricles, and includes the *relative refractory period*.

“U” occurs occasionally, corresponding to the dying out of excitation in the terminal branches of the conducting system.

A **second** mechanism leading to electrical fibrillation is the rapidly repeated, moderate intensity electrical stimulation of the myocardium by a succession of electrical pulses.

A **third** mechanism is the fibrillation reported by Peleska [1963] where extremely strong electrical currents cause long-term damage to refractoriness and excitability of the myocardium.

It is known that the *larger* the heart, the *more* susceptible it is to fibrillation, a fact that lends support to our present understanding of the phenomenon.

The *alteration of the polarization pattern contributed by exogenous current flow* establishes a **new center** from which depolarization starts, termed the “**ectopic focus**”. The **normal depolarization pattern set up by the nodes of the heart is thus defeated**. *Once this is done, the new distorted pattern*

*becomes self-perpetuating, due to the particular pattern of **absolute and relative refractory tissues it has itself set up**. This stimulation pattern is not geometrically aligned with the anatomical stimulation system of the heart. This self-perpetuation of the imbalance is labeled “circus movement” or “reentry” of excitation.*

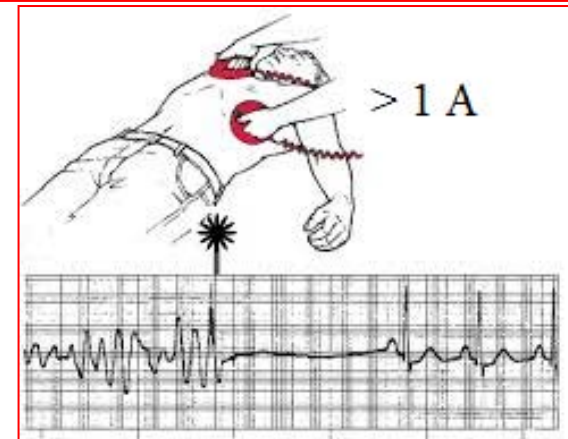
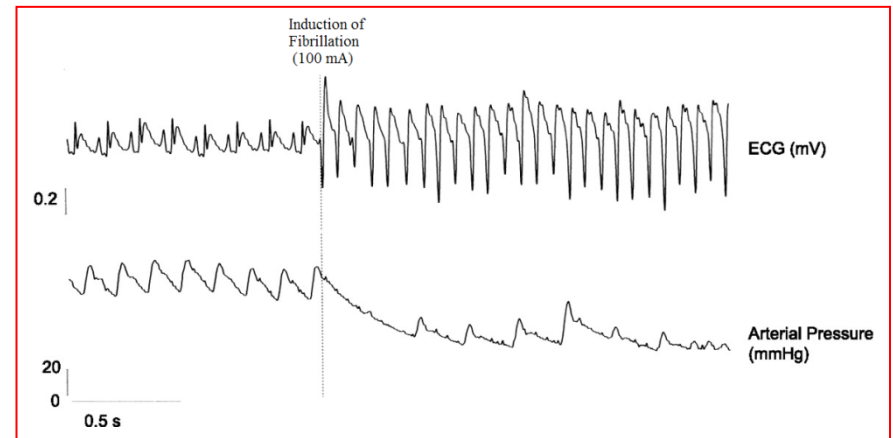

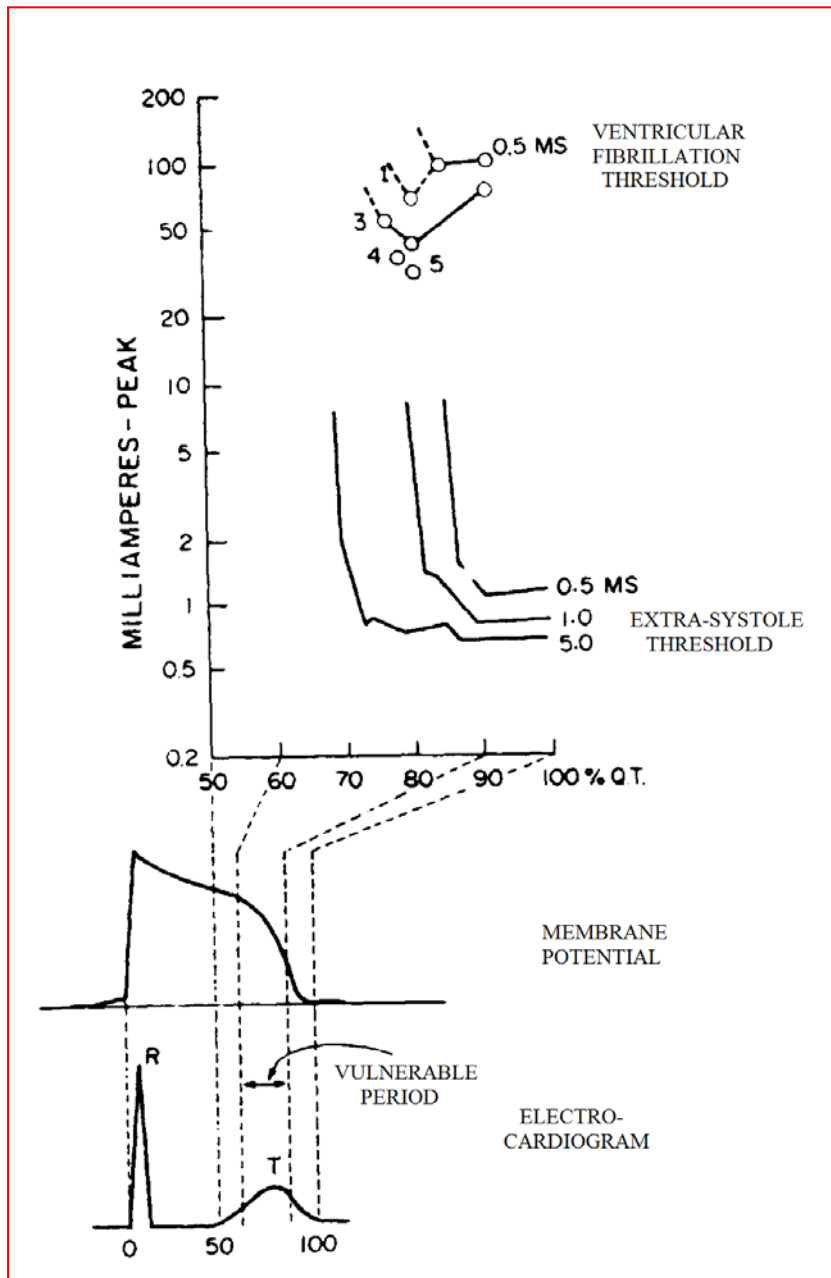

The heart is particularly vulnerable to fibrillation during a period centered on the rising T segment of the electrocardiogram. A single supra-threshold current pulse during the critical recovery to excitability of the heart muscle, when parts of the heart are still absolutely refractory, and others relatively so, can be lethal.

Because the electrical activity is uncoordinated under fibrillation, the ventricles do not fill and expel blood effectively. Circulation is arrested, unconsciousness ensues within 10 seconds, and **death results within minutes**. The ECG during ventricular flutter and fibrillation are shown in the previous figures. *Flutter and fibrillation of heart muscle can also be set off by oxygen deficiency, coronary occlusion, cardiac over-stretching, low temperature, overdose of drugs and anesthetics.*

Ventricular fibrillation is the most acute cause of death in electrical accidents.

Electrical currents can also **defibrillate** the heart. A single brief shock, applied across the intact chest wall with large surface electrodes, and a few amperes in magnitude, usually stops fibrillation instantly. It is the most effective method of abolishing ventricular fibrillation. Its effect is due to the synchronization of all parts of the myocardium under the powerful current pulse.

Leakage current to a cement mixer frame

Completing work at an outdoor construction site, a worker was sent to clean out an electrically operated (230 V) cement mixer with a water hose. When co-workers checked on the victim, he was found several feet from the mixer, pulseless and not breathing. The hose was nearby, still pouring water. When the paramedic arrived, the victim could not be resuscitated and the ECG showed coarse ventricular fibrillation. The distance of the victim from the mixer is probably related to the muscular contraction due to the shock delivered from the metal parts of the mixer. The mixer was later found to be ungrounded, with high leakage current to the mixer frame.

Medical officers within large industries where accidental exposure to electrical current is likely should be equipped and ready to apply this defibrillation procedure (see below).

2.1.6.2. Fibrillation threshold: duration and energy of shock

The threshold of fibrillation (as determined in dogs and sheep for 60-Hz current) is dependent upon the duration of current application according to a relation of the form⁴:

$$I = \frac{116}{\sqrt{t}}$$

⁴ Note that this equation is compatible with the idea that a given **threshold energy** is the metric determining fibrillation in brief electrical shocks: I^2 , which is proportional to power, is inversely proportional to time in the equation above.

If I is in mA and t in seconds, 116 is the appropriate value for adults, using a criterion of 0.5% fibrillation probability in a 50 kg person.

Voltage is only indirectly involved in cardiac fibrillation, since current (and therefore the potential occurring in the heart muscle itself) is the important factor.

For safety considerations, the time of current application is of great practical importance: a high voltage source which would normally be able to output lethal currents *can be made safe* by limiting the *time* during which it is allowed to supply a current above the steady-state current fibrillation threshold.

In other words, a safety circuit would detect any current above 5 mA, and interrupt current flow lasting more than approximately 8 msec.

The diagram below shows the various safety zones according to Publication 479 from the International Electrotechnical Commission.

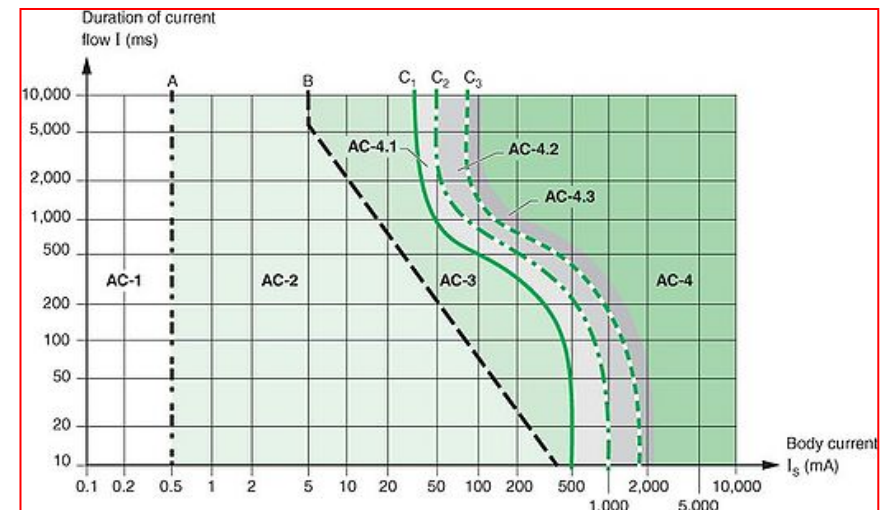

Current-time ranges for the effects of alternating currents (15-100 Hz) in man.

Range 1: In general not perceived.

Range 2. In general no hazard to health.

Range 3. In general no organic damage to be expected. Increasingly severe muscular contraction and possibly respiratory problems, reversible conduction defects and pace-setting disorders of the heart, including atrial fibrillation and transient cardiac arrest without ventricular fibrillation. The effects become more serious with increasing current strengths and exposure times.

Range 4. In addition to the effect described under Range 3, increasing probability of ventricular fibrillation up to about 5% (curve C2), up to about 50% (curve C3), and over 50% (above curve C3). Pathophysiological effects such as cardiac arrest, respiratory arrest and serious burns become more frequent with an increase in the current strength and exposure time. Notice that the bend in the curves centers on the time-span of a PQRST complex.

Under most circumstances, very short shocks are not generally believed to have long lasting effects beyond the nervous [Reilly, 1985] and transient physiological reactions that have been reported [Guderian, 1986].

Sinusoidal currents of frequencies other than 50-60 Hz also have the capacity for cell stimulation. Frequencies lower than the power frequency range are less effective at stimulating cells, and consequently pose a smaller risk. As well, above the power frequency range, the various thresholds tend to increase with frequency. A conservative threshold for cell stimulation is $(35 \times f)$ mA/cm where f is in MHz [IEEE, 1991].

2.1.6.3. Defibrillation

The treatment for cardiac fibrillation is correction of the abnormal electrical pattern within the heart, but a temporary measure is the administration of cardiopulmonary resuscitation [JAMA, 1992]. CPR, although only effective for a short period of time, keeps the organs alive while preparing for therapeutic electrical shocks. Defibrillation is often effective, but some

conditions, such as mechanical failure of weakened myocytes, are not treatable by therapeutic electrical shocks.



The electrical shocks most effective for defibrillation are short pulses of about 6 msec at 70 A [Gold, 1979]. To be effective, defibrillation must be applied within 12 minutes, although in some cases, victims of electrical accidents can be brought back to life as late as two hours after the shock [Hauf, 1985].

Large industrial facilities where electrical risks exist should be equipped to administer defibrillation treatments. Upon arrival on the scene of an electrical accident, and after verifying cardiac arrest in a victim (absence of pulse), CPR should be started, and preparations made for defibrillation treatment. In the absence of medically trained staff, a defibrillation-competent hygienist may be a good person to administer this treatment.

Good planning, supervision and maintenance of Automated External Defibrillators in public areas insure reductions in mortality. For example, school-based automated external defibrillators programs provide a 67% survival rate (based on hospital discharge) for student athletes and older non-students who suffer sudden cardiac arrest [Drezner, 2009].

Pathology	Treatment
Ventricular Tachycardia progressing to Ventricular Fibrillation-Asystole (Adam-Stokes)	Electrical Pacing
Atrial Tachyarrhythmia, Ventricular Tachycardia	Low-Energy Synchronized shocks (cardioversion)
Ventricular Fibrillation (electrical accident)	High Energy Unsynchronized shocks

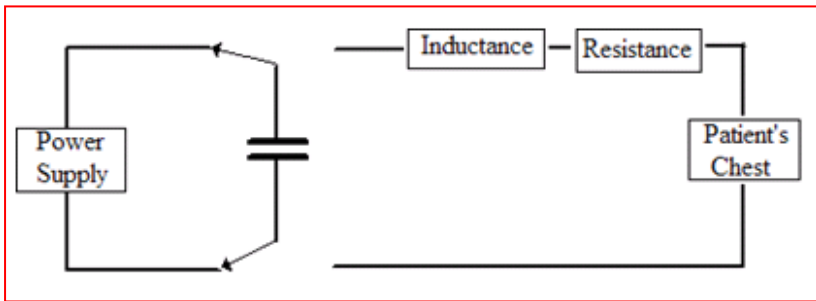

2.1.6.4. Defibrillation Devices

The instrument contains a pair of 25 μF capacitors charged to 2500 V in parallel. They are then discharged in series through a 56 mH inductance. The electrical energy ($\sim 440 \text{ J}$) stored in the capacitors is discharged through a current-limiting circuit which includes the chest of the patient (see above).

It should be kept in mind that the $\sim 3500 \text{ V}$ shock from a defibrillator has the capacity to induce fibrillation in careless users (who would not be clear of the patient at the moment of shock administration). The intensity of the shock will be substantially affected by the resistance of the chest and by the contact resistance ($\sim 50 \Omega$, varying between 15 and 143 Ω) [Kerber 1981].

2.1.6.5. Manual and Automatic Defibrillators

Most equipment designed to deliver therapeutic electric shocks allow the monitoring of heart signals through the paddles used to administer the shock. In the case of electrical accident and in the absence of a pulse, electric shock should be administered even in the absence of cardiac monitoring (blind defibrillation). Such an approach, although not ideal, is even appropriate for cardiac arrest victims generally [Tacker 1994].

The recommendations of the American Heart Association Emergency Cardiac Care Conference guidelines for CPR are as follows:

- three defibrillation shocks of 200, 300, and 360 Joules (excessive energy can damage pacemakers and heart tissues),
- if shocks are ineffective, intravenous epinephrine, chest compression (107/minute, depth 4.7 cm) and ventilation,
- second series of defibrillation shocks.

2.1.6.6. Pacemaker implantation

Pacemakers are implanted in about 0.25% of people to reduce cardiac risks in subjects with a damaged myocardium.

Developments have also allowed these electronic devices to function as defibrillators.

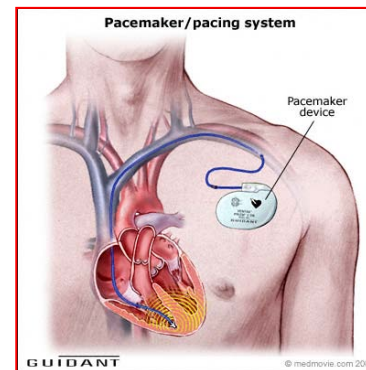

Precordial thumps (chest punches) defibrillate only 2% of patients with recent onset of ventricular fibrillation. They can also convert ventricular tachycardia into ventricular fibrillation.

Advanced pacemakers regularly estimates the minimum energy needed to stimulate the heart's

upper and lower chambers, and automatically adjusts the intensity of electrical impulses delivered to both chambers, without physician intervention.

Implanted defibrillators reduce the occurrence of sudden death by almost a third among people with impaired heart function [Moss, 2002].

But electronic devices regulating heart beat do not completely follow human physiology. Injections of adenovirus vectors containing the TBX18 gene into heart muscle allow the muscle to adopt the morphology and markers of pacemaker cells and, more importantly, to act like them. The reprogrammed pacemakers exhibit natural rises and falls in heart rate over day and night cycles, as well as increased heart rate during physical exercise [Hu, 2014].

Dangerous Dielectric Tests?

A worker refuses to work using a dielectric test set because he has been the victim of a shock, which resulted in strong muscular contraction and some pain. The maximum rating of the equipment, 100 mA_{rms} at 20 kV, is impressive enough to support his fear.

Expertise shows that the test set in question is fitted with a rapid switch which interrupts the current, should a low impedance be detected. Because the protection system reacts reliably under 20 msec, the condition is labeled as safe, and work is continued.

2.1.7. Epidemiology of Electrical Accidents

Although the risks associated with electricity (electrocution) do not compare with those associated with motor vehicles, they are nonetheless substantial [Chapman, 1994], carrying a 0.048% average lifetime mortality risk (and being much higher in some occupations).

In the occupational sector, electrical risks seem to favor the younger workers [Rossignol, 1994]. Most of the deaths from electrical accidents are occupational.

The public's *perception* of the health risks associated with the use of *electricity* is the second most **under evaluated**, right after the risk of drowning (as compared with the perception of the risks associated with firearms, nuclear power, polluting emissions, automobile, etc).

In fact, electrical incidents are remarkable in their lethality and consequent morbidity. The ratio of fatalities:injuries:incidents is nominally 1:30:300 in Heinrich's pyramid, but is 1:4:25 in electrical accidents.

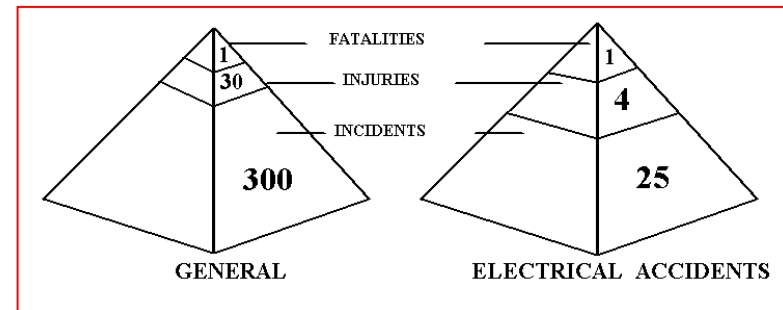

2.1.7.1. Deaths

In 1888, in the US, 200 people died from electrical accidents. Presently, there are approximately 1350 deaths per year in the US, a relatively modest number, considering the increase in electricity use. 50 to 60 deaths per year are recorded in Canada. Domestic electrical injuries in Canada are only 130/year (fatalities are about 8%), much smaller than occupational rates. Disparities between different countries are significant. The number of deaths has a historical tendency to stabilize, not following the increase in power consumption, as *security measures have had a powerful influence*.

Presently, the majority of accidents originate in human error. The causes of deaths are contacts with overhead lines, 120 V or industrial voltage levels.

2.1.7.2. Work Injuries

“A cool head and a steady nerve, with a smattering of electrical knowledge, are the prerequisites of a first-class lineman. Unless a man be apt to judge and quick to remember, he will be liable to serious blunders in his manipulations of the wires. Where there are dozens of them attached to one pole, he should be able readily to distinguish each from the others and have no doubt as to whether it be quick or dead. Contact with the earth through means of a conductor should be shunned like death itself. So long, however, as the lineman sits astride the cross-piece of a wooden telegraph pole and confines his attention solely to a wire that has no communication with the earth, he is as safe as if he were in his mother’s arms.”

Scientific American, July 1889.

There are about 800 occupational electrical injuries a year in Canada [Hotte et al, 1990], with at least 50 in Québec. At Electricité de France, 25 accidents, 5 of which deadly, occur every year. At Hydro-Québec, 5 electrical accidents are recorded yearly with one casualty.

93% of electrical accidents in the industry involve **burns**, either by arc or by passage of the current through the body, or both. There are **wounds to the upper extremities** in 75% of cases. *The destructive element is heat* [Daniel 1987].

Electrical burns represent only 4% of all burns, which explains why specific expertise for their treatment has been slow in developing. It is difficult to estimate by eye the damage done to the tissue by heat which has already dissipated, sometimes leaving the tissue with a misleading appearance of health.

Electricians are the occupational group most at risk of electrical injury (0.3%/year), principally as a result of arc burns. Second are linemen (0.26%/year), but with a higher risk of fatality because accidents result from actual contact with high voltage wires. Other groups at risk are welders, laborers in certain industries, and motor vehicle and heavy equipment mechanics.

Scenarios are diverse: changing fuses under power, testing 600 V voltages with an instrument in the Ohms setting, arc burns in welders, bridging electrical terminals with a metal watch band, etc.

Problem 15. A cow is grazing in a square pasture 10 m on a side below a transmission line. The field intensity at ground level is 10 kV/m. The pasture is limited by a floating metallic wire 1m above ground. If the cow touches the wire with its mouth, will it feel a discharge knowing that the short circuit current of a fence is $I \text{ (mA)} = 0.0025EhL$, where E is the electric field in kV/m, h is the height above ground in metres, and L is the length of the fence in m, and that its threshold of perception is 0.5 mA?

Problem 16. In the disposition shown, point A is energized, point B is coupled to A by 10 pF, and point C is grounded. The subject bridges B and C as shown with an effective resistance of 200 ohms. If A is energized at 60 Hz and at 1000 V, what current will flow through the subject? What potential difference is applied across the subject? If A is energized at 100 MHz and at 1000 V, what current will flow through the subject? What potential difference is applied across the subject?

Problem 17. 11 identical metallic plates are uniformly spaced in a stack by insulating plates of infinite resistivity. An electric potential of 100 V is applied across the top and bottom plates at 60 Hz. What is the potential across two adjacent metallic plates? The frequency is shifted to 6000 Hz. What is the

potential across two adjacent metallic plates? What electrical characteristic is substantially affected by the change in frequency? If 2 plates are electrically bridged, describe the potential repartition among the plates afterward.

Problem 18. Knowing that the lethal minimum for a capacitor discharge to a human is 30 J of energy, calculate the voltage necessary to kill an electronic technician contacting a 200 μF capacitor. $E = \frac{1}{2}CV^2$.

2.1.8. Electrical Burns

Around 1890, Edison and Westinghouse were arguing about the relative practical merits and safety of DC and AC currents. The Edison interests, whose business rested on direct current electricity, arranged for Westinghouse to win the contract for the electric chair at Sing Sing, a New York State penitentiary⁵. For perspective, the voltage used in electric chairs is in the neighborhood of 2000 V.

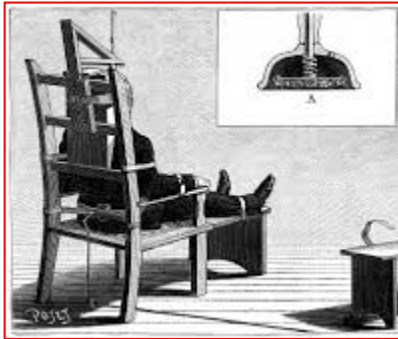

Westinghouse's ac electric chair, as depicted in *La Nature* (Paris) in September 1890. A laconic note pointed out that three surges of current were needed to finish off the criminal Kemmler, the first person to be executed in the chair.

Since a head electrode is commonly used, it is believed

that death of the condemned subject results from thermal degeneration of brain tissue.

⁵ However, the demonstration that ac could kill did not save dc. In fact, dc electric chairs were also used with currents from 100 mA to 5 A for 2 minutes, head-to-leg.

Electrical burn wounds possess special clinical characteristics, particularly when involving voltages above 1000 V. Below that level, lesions are usually minor, cardiac fibrillation being the major risk. Above 1000 V, there is a risk of a pernicious wound which can lead to limb amputation.

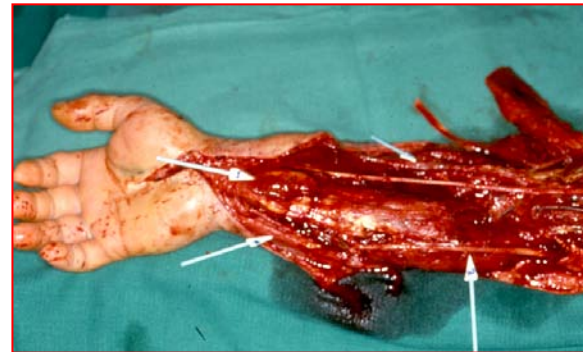

Problem 19. Since both DC and AC can kill, how was the choice made between DC and AC technology in implementation of large electrical networks: what won the fight with Edison for Westinghouse?

2.1.8.1. Surgical Aspects of Electrical Burns Treatment

Physicians often describe “entry” and “exit” wounds on the skin of victims, in analogy with gunshot wounds, where the exit is more severe. The cutaneous wounds seen in the clinic should more appropriately be called “first” and “second” contact wounds, since the current is alternating, and there is no such thing as current entering or leaving. The actual situation is one in which one contact is more firmly established (lower resistance) than the other.

The *cutaneous aspect* of a high voltage electrical burn does not always give a **dependable indication** of severity, and *deep proximal lesions may occur in the limb*. Especially in the case

of larger contact areas, *the cutaneous lesions may occasionally be very small* [Adjuvantis, 1973], *with internal damage extending beyond the contact area.*

Surgical intervention is needed if myoglobin will not clear, or acidosis will not resolve. Thorough removal of grossly necrotic tissues can improve these conditions. Escharotomy and fasciotomy relieve compartment syndrome. In absence of serious symptoms, a delay of a few days can often allow definitive debridement and wound closure in a single operation.

Small electrical injuries can swell tissues within the carpal tunnel (median nerve), manifesting as paresthesias and numbness.

Particularities of electrical burns are in great part due to the ability of electricity to inject substantial currents through small electric arcs, and to the complicated patterns of current circulation within the limbs. Such currents can be measured experimentally within the limbs [Héroux, 1985, 1985a], but their pattern is difficult to predict effectively.

The electrical burn wound is characterized by:

- **Considerable muscular lysis** with release of myoglobin in the blood, saturation of the haptoglobin scavenging system and renal toxicity (the reason for the recommended use of mannitol).
- **Vascular alterations**, including at the micro circulatory level.
- **Sub-fascial edema** (compartment syndrome).
- **Relative absence of pain** (due to destruction of nervous tissue).

Edema swells tissues: normal muscle section at top, thermally injured muscle at bottom.

Clinically, the treatment is complicated by the apparent phenomenon of *progressive necrosis* [Zelt 1986, 1986a] and the need for multiple surgical interventions (successive debridements). The surgeon's difficulty is essentially related to the identification of viable and non-viable tissues and their management [Daniel, 1988, 1988a; Zelt, 1988]. The complicated pattern of electrical burns inside the body [Héroux, 1992, 1993c] represents a substantial problem which could be solved by using advanced diagnostic techniques, including sensing tissue state by Electrical Impedance Spectroscopy [Héroux, 1993, 1994, 1993b] and advanced imaging devices (MRI).

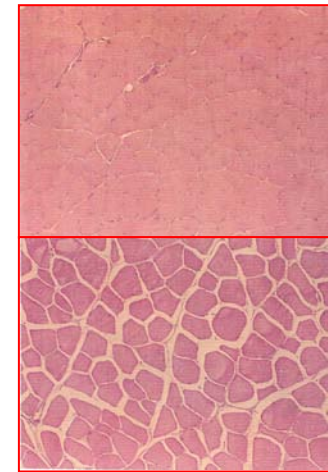

Damage patterns within the arm of a high energy burn victim are irregular. Dark terazolium stain indicates viable tissue.

The primary mechanism of damage in electrical burns is heat [Héroux, 1986]. In some instances, it is possible that injury related to dielectric effects as well as heat may contribute to the pathology of electric shocks [Héroux,

1991], but these cases are a small minority and would not be characterized by large scale tissue necrosis. However, the exact conditions under which dielectric effects can contribute to pathology have not been investigated in detail, and the limit between thermal wound and dielectric wounds is undefined. The basis for believing that dielectric effects are rarely of importance is the relative innocuousness of any very brief electrical shock [Héroux, 1993]. Rarely, dielectric effects may be at the root of neurological sequelae (below) in brief shocks.

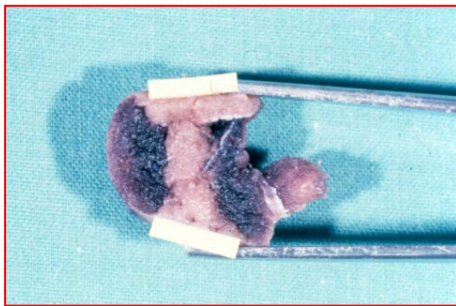

Non-thermal dielectric wound delimited by tetrazolium stain. 6 shocks of 1720 V, 10 μ sec, 8.6 A. 7.5 mm rat gluteus thickness. Temperature rise, 0.43 K. The rectangles are electrode positions [Héroux, 1993].

A case of arc burn

A 31-year old fitter's helper was working in a substation when a three-phase flashover occurred on the 11 kV circuit. He received burns to the back of his hands and front of the face, neck and right wrist (hospital stay of 3 weeks). The worker remembers little of what happened, having only islands of memory until about three days after the accident. Artificial respiration was administered at the time of the accident by his co-workers.

2.1.8.1. Neurological and other sequelae

A variety of *neurological and other sequelae* have been reported [Rogado, 1976; Haase, 1959], *sometimes years after the incident*, following electrical burns. These are due to the particular sensitivity of nervous tissues to electric current flow. This specific sensitivity may be explained in terms of *electroporation* (see section *Electropuncture and Electroporation* in Appendix 3 of Chapter 3.)

Cataract (5% to 10% incidence) can occur [Moriarty 1987] in the period following the accident (average, 6 months) even in the absence of contact points on the face or head.

High-voltage injury victims should receive 24-hour cardiac monitoring, and a cardiac isoenzymes determination.

In a 10 year study conducted at Electricité de France involving 1231 cases [Gourbière, 1986], delayed **cardiac pathology** was observed to occur in 0.8% of cases, with the following breakdown: 1 case of palpitations, 1 case of spontaneous hypertension, 6 cases of rhythm alterations: sinus tachycardia, ventricular tachycardia (subject deceased), ventricular extra systoles (2 cases, 1 deadly), tachy-arrhythmia from auricular fibrillation (2, 1 deadly), 1 infarct of the myocardium, 1 infarct of the posterior myocardium. The last two cases did not involve pain symptoms. Among the three dead, two were in contact with high voltages (25 and 90 kV) and one with low voltage 220-380 V.



More tissue damage surrounding the joints (here, elbow) is typical of severe electrical injuries.

2.2. Electrical Safety Procedures

All electrical safety procedures have a single goal: to eliminate situations in which the human body becomes a conductor of electricity.

Safety has increased tremendously as we have learned to handle electricity. Today, it appears that the majority of incidents involve **human error**. An effort to eliminate such errors can be made in the form of *barriers leaving no alternatives* in the course of the work procedures.

2.2.1. Legal Guidelines

2.2.1.1. Origin of Rulings

The *safety level* achieved in a given electrical system depends first on correct *installation procedures*, such as described either in the provincial electrical safety regulations (specifying procedures for domestic and industrial wiring) or in the recommendations of the Canadian Electrical Code, Part I (January 2012), which prescribes standards of design, installation, operation and maintenance of electrical equipment, mostly as described in Canadian Standards Association [CSA] documents. In practice, it is also necessary to refer to

additional standards including Underwriters Laboratories, the British Standards Institution and the International Electrotechnical Commission.

The characteristics of electrical devices are recorded on metallic plaques inscribed with the ratings of particular pieces of equipment. The details of application of the rules found in the codes are not simple. The codes only supply rules without explanations. It is the job of the safety officer to interpret the rules and apply them properly.

The second aspect relates to Health and Safety procedures aimed at integrating electrical safety programs into Occupational Health and Safety management systems, best safety practices for work on and around electrical equipment, guidance on due diligence in prevention of electrical injuries, methods for identifying electrical hazards and assessing risk and targets for electrical hazard awareness and training for workers. For this, one should refer to the second edition of CSA Z462, released in early January 2012.

2.2.1.2. Rate of Safety Rules Violations in the Workplace

OSHA in the US periodically releases listings of the standards which are the most frequently cited for violations by its compliance officers. Certain standards consistently rank high in terms of the number of observed violations. *In first place is the National Electrical Code.*

The Safety Codes, if respected, determine an extremely high level of safety, and further include redundancy (or “double insulation”). Although real hazards are created by inadequate installations ignoring the requirements of safety codes, incidents or accidents will not necessarily occur immediately and may never occur at all unless a second breach of standards or practices happens. Often, accidents are not immediately

associated with a violation, but occur during subsequent procedures.

2.2.1.3. Infractions involving Grounding Connections

Defeating or ignoring recommendations on the grounding of equipment represent **the most immediate threat to human life**. In many industrial installations, metallic housings are often left **electrically floating** (by negligence) rather than connected to a **rigid ground** (conductor of good size). When a fault occurs and is not detected, workers may get a lethal shock by contact with such equipment.

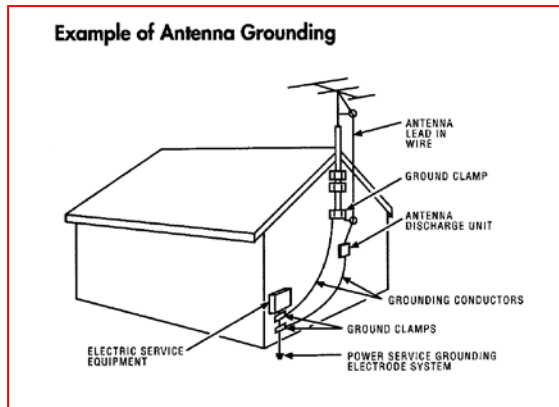

Grounding should not be left to the discretion of the workmen installing the equipment. This aspect of the electrical system is the direct responsibility of the safety officer, and should be checked with the assistance of electricians.

A home electrical system will function perfectly *even if the grounding wire connections (3rd pin) are not in place*. Polarized plugs can be defeated and inverted by altering the contact blades. Most of these infractions will not result in

immediate danger. In the event of a fault, however, such transgressions can be of considerable consequence.

It is the duty of the safety officer to make sure that appropriate grounding is installed by competent electricians in the industrial setting.

Problem 20. What represents a grounding connection of proper capacity?

In an urban setting, there exists an ideal grounded reference which is almost universally used: the *underground water pipes*. Connection to the pipes through a wire of suitable capacity insures a ground of excellent quality. However, inspections of water pipe grounding systems often reveal them to be lacking due to a **lack of continuity of the piping** and/or to lack of a **good electrical bond** between pipe and electrical conductor (corrosion). For equipment of exceptional current capacity, it may be necessary to provide a *separate grounding conductor* because the potential along the normal grounding path in the event of a large surge may be sufficient to affect human safety or damage other delicate equipment.

In the country, or in other special situations, an extensive network of pipes is unavailable, and a **metallic spike** is often driven into the ground to provide a potential reference. The quality of such a ground will depend on the *conductivity of the soil, the length of the spike and its diameter, and, over the long run, on its corrosion properties*. Corrosion-resistant metallic spikes inserted into the ground must be long enough so that they are in contact with soil containing more than 15-20% moisture, otherwise *conductivity may be too poor* for adequate performance. In the winter, freezing decreases the soil conductivity, and spikes should be long enough to reach below

the freezing zone. Portable equipment for ground resistance testing is available.

An empirical formula is available to evaluate the resistance to ground of a grounding rod of specific size inserted in soils of known conductivity.

$$R = \frac{P \log_{10} \left(\frac{4L}{d} \right)}{2.72 L}$$

where P is the soil resistivity in Ω -cm, L is length in cm and d is diameter in cm. Clay, for example, has a resistivity range of 500 to 10,000 Ω -cm.

2.2.1.4. Infracctions involving Dielectric Insulation

When the *voltage rating* of wires, switching apparatus or any other device is exceeded, **breakdown of insulation or flashover** in air can result. These faults will result in power interruption in a properly engineered electrical system, in which the first requirement is that **an interrupting device in the form of a fuse or of a circuit breaker can cut power in the event of a fault**. A fuse is rated according to its maximum applied voltage and current -at which the fusible element melts- and also, especially at high ratings, according to the maximum current it can interrupt in the event of a fault.

2.2.1.5. Infracctions involving Current Capacity

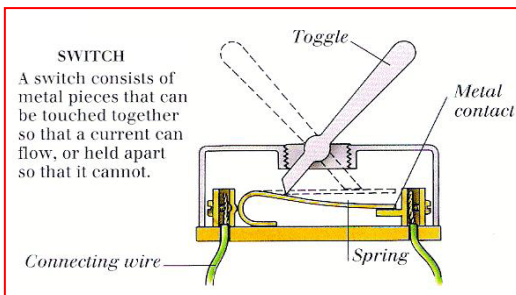

Electrical contacts in switches and electrical connections have a *limited capacity to carry current* which is determined by their

electrical resistance and the capacity for heat diffusion of their metallic contacting surfaces. Overloading will result in deterioration of the contact, especially upon opening of a switch.

Overloaded wires allow *elastomer insulation (rubber, polyethylene)* to degrade over time from heat, and catch fire.

Breakers are specifically designed to interrupt power under a designed-in overload condition. However, a large current overload may also result in inability of an interrupting device to cut current, thereby *eliminating the effectiveness of the safety system*. Designers often arrange electrical configurations in such a way that manually activated switches are in series with a circuit breaker (which operates automatically⁶). In the situation in which a circuit breaker fails to interrupt power, the last recourse is often to use the manually operated switch. Unless properly dimensioned, the switch may also fail in such a situation, at risk to the operator. The importance of interrupting capacity in industrial electrical applications is of importance at the highest electrical powers.

2.2.2. Safety at Home

In the home, a variety of simple techniques have been employed to insure electrical safety, and the principles used are equally applicable in any setting.

2.2.2.1. Fuses and Breakers

Fuses and breakers are installed in the electrical box of a house to prevent circuit overloading, which would lead to wire

⁶ Some circuit breakers of medium capacity are built using a metallic blade which dilates according to its temperature, and slips off the contacting surface when the designed temperature is exceeded.

overheating and to *decay and perhaps ignition of the insulation*. Furthermore, in the event of a dielectric incident (flashover), **fuses and breakers will disable the faulty circuit, but possibly not soon enough to avoid the loss of human life.**



2.2.2.2. Casing Grounding

Contemporary electrical plugs have a 3rd (round) pin which is connected through a **grounding wire** to the *conductive case of an appliance*. This grounding wire is

connected to earth potential in the electrical box, and serves for *personal safety against electric shock* and as an electric shield return. This ground wire is therefore at ground potential, just like the neutral wire, but has the role of **maintaining the exterior metallic casing or frame of an electrical appliance to ground potential**. Should the appliance be faulty, and should the energized wire touch the casing (a potential danger), return current would flow in quantity

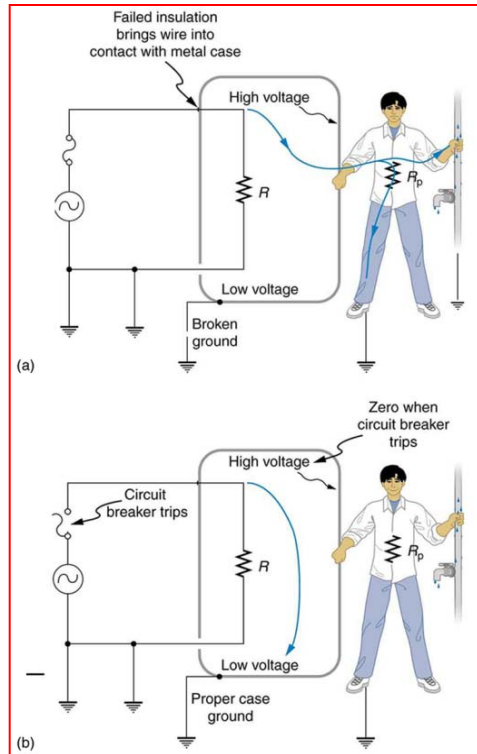

through the grounding wire, and the fuse or breaker would *operate automatically* (see figure).

2.2.2.3. Double Insulation

Another safety feature, frequent in many appliances, which prevents contact between energized parts and users, is **double insulation**.

Double insulation is defined as “a method of insulation by which accessible parts are separated from live parts by **both functional and protective insulation**”. *Functional insulation* would be, for example, the insulation on electrical wires going into the body of an electric drill. *Protective insulation* would be a plastic cover insulating the metallic case of the drill from the user’s hand.

Therefore, in double insulation, *no danger would occur to the user even if the primary insulation* (that of the power circuit, ie, the two power wires) *was to fail* (a description of “double insulation” standards can be found in Part 7 of CSA Standard C22.2 No. 71.1-M1985, Portable Electric Tools). Double insulated tools are the only ones with two-wire plugs sold today which are approved by the Underwriter’s Laboratories (UL).

Another, older, method is to use *plugs that are polarized* (one blade wider than the other) to insure that the energized conductor will always be connected to the switched contact of an appliance. In this way, the energized conductor is the one that is interrupted by the switch, rather than the ground return. As well, many appliances are **asymmetrical**, and the energized conductor is connected to the point in the appliance which is the *least likely to come in contact with the casing* (and thus a human) *in the event of failure*.

Time-Life Books, 1989

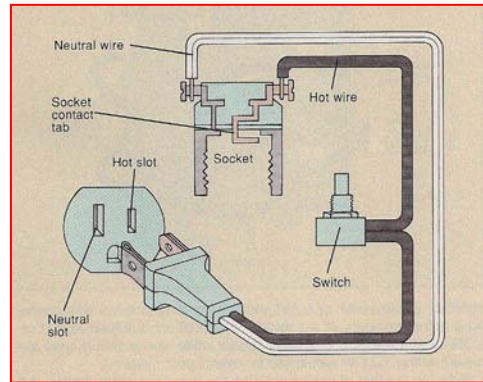

2.2.2.4. Ground Fault Circuit Interrupter

A differential breaking outlet has now become mandatory for high risk areas such as bathrooms, garages, basements, outdoors and within 2 m of kitchen sinks. It is also highly recommended in its portable form for work on **construction sites**, where unpredictable events are particularly frequent. It is

called a *Ground Fault Circuit Interrupter (GFCI)*. This electrical outlet *measures the current flowing in and out of the outlet through the energized wire and the grounded power return*. If there is even a **small difference** (~6 mA) **in the value of the currents**, this indicates that current is leaking either through the 3rd wire, an *insulation fault condition*, or *through some other grounding path, such as the body of a human*. The outlet automatically deactivates itself in this



condition[♦]. Such outlets are particularly *recommended for outdoor situations* when rainwater may make good human grounding more likely.⁷

This type of protection can be installed in a given outlet during construction, in the main electrical box on specific circuits, or carried around as a box to be plugged into a regular two-wire outlet. In this last case, it substitutes for a third grounded wire. According to Hotte [1990], about 60% of accident scenarios would have been avoided by the use of ground fault circuit interrupters. However, in many of these situations, none were required by the Canadian Electrical Code in the locations of the accidents. While portable units could have been used, it is unlikely that the victims would have used them, judging by the hazardous conditions many of them placed themselves in. The remaining 40% of accidents involved fixed appliances, service wires and suicides.

Problem 21. A GFCI can detect very low levels of current going to ground. When put in line between the power outlet and the tool you are using, the GFCI protects you because:
A -it runs on batteries
B -it can handle higher current loads than a standard breaker
C -it will trip much faster than a standard breaker
D -like a step-down transformer, it reduces the voltage to 12 V

[♦] For example, at 6 mA, UL943 requires the GFCI to interrupt within 5594 msec (5.6 seconds), at 10 mA it must interrupt within 2694 msec (2.4 seconds), at 25 mA it must interrupt at 726 msec (0.73 seconds) and at 250 mA is must interrupt at 25 msec.

⁷ GFCIs may also include solid-state surge-absorbing devices. Often based on metal oxide semi-conductors, these surge absorbing devices can absorb up to 100 J of energy, and attenuate line surges up to 6000 V. These devices offer no protection against large surges induced by close lightning strikes, due to insufficient energy-handling ability.

2.2.2.5. Water Risks

Water, in any setting, is a threat in electrical accidents because it increases the conductivity of human skin and of other objects (mostly by increasing their surface conductivity), thereby reducing contact and circuit resistances, which allows more current to pass through the human body in case of accident.

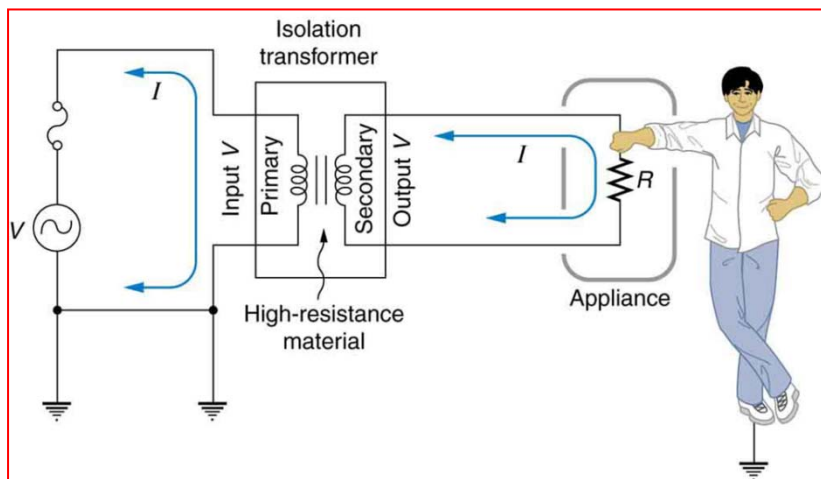

In bathrooms, two elements are present to promote ground connections of great quality: water and metallic plumbing. To reduce risks, electrical outlets in older bathrooms were equipped with **insulation transformers** (before the introduction of ground fault circuit interrupters).

An insulation transformer is a small transformer placed within the power outlet which does not change the voltage ratio between primary and secondary, but allows the ground reference potential to be “lost” at the secondary.

Since both the sector circuit below and the subject are connected to ground (one through a permanent connection and the other through hand contact with the sink), it is only necessary for a live wire from the sector circuit to touch the subject at any point on his body for electric current to flow (an electric loop is completed).

However, the insulation transformer acts as a small independent power source, since it is not connected to the power circuit by any wire. The transformer passes **power** through its magnetic circuit, but is independent of the **voltage level** of the sector circuit. For the subject to be shocked, it would be necessary for him to be connected *across* the two wires coming from the **secondary** of the insulation transformer, an event which is less probable, and also less likely to pass current through the heart of the subject because the wire pair spans little space.

2.2.3. Safety in Industry

In industry, the use of electric power involves diverse situations. There has been considerable effort to standardize and rate the equipment, as described previously, and also to insure safety in the work procedures. *This is mainly achieved by physical barriers which prevent access to live parts when under power.*

2.2.3.1. Door Interlock

The simplest of such devices is a *door interlock*. It consists of a switch which insures that voltage is interrupted to an object under voltage unless a door is closed. In many instances, such a measure is extremely effective.

It is extensively applied to the case of *small metal cabinets* containing *circuit breakers or switches*. However, workers may circumvent interlocks by simple mechanical means. This

occurs particularly when large work areas are fitted with an interlock. For example, working in pairs, one of the workers may remain inside the area to diagnose a problem while the second operates the equipment. Such situations usually do not result in accidents, as transgressing the safety rules at least momentarily increases worker awareness of the dangers.

But safety officers who place unreasonable requirements on the work procedures run a high risk that the imposed measures will be circumvented, and in the case of an interlock, it is particularly easy to do so.

2.2.3.2. Padlocking (lockout)

A second technique related primarily to the operation of switching equipment is “*padlocking*”. When more than one worker is assigned to perform a maintenance job on a fixed system which extends physically to many locations (say, a motor in one room, with the controls of the motor in a remote location), the possibility of unexpected operation represents a substantial hazard. OSHA estimates that half of all fixed machine fatalities could have been avoided with proper padlocking.

The padlocking method arranges that equipment controls such as blade switches or circuit-breakers *are locked open unless a certain number of keys are inserted into padlocks or locks integrated or attached to the equipment*. The logic allowing operation of the controls can be brought to any degree of **theoretical safety** level by advanced planning. A warning tag can also be fixed to the locking device. Whenever possible, the worker should interrupt and lock the **switch itself (disabled 2nd) rather than the control circuit**



(disabled 1st). An array of tags used in industry is displayed.

A few quotations from the literature...

7% of all workplace deaths and nearly 10% of serious accidents in major industrial groups are associated with failure to properly restrain or de-energize equipment during maintenance.

US Dept. Labor News release 88-223, April 29, 1988

6% of workplace deaths in 1991 in the US resulted from unexpected activation: 120 fatalities, 28,000 serious injuries, 32,000 minor injuries.

A. Carney, Lockout the chance for injury, *Safety and Health*, 143(4), 46-49, 1991

Failing to lock out is ranked third in OSHA's list of citations.

B. Knill, Lockout/Tagout makes a list of top ten OSHA citations, *Material Handling Engineering*, 49, 37-38

Just 20% of employers in the USA adequately protect their workers from injury and death due to accidental activation of machinery.

L.E. Oppriecht, Control Energy, *Occupational Health and Safety*, March 1995, p. 40

OSHA, 1990: Control of Hazardous Energy (Lockout/Tagout CFR 1910.147) requires employers to “develop and utilize a comprehensive energy control programs consisting of procedures for shutting down and isolating machines and equipment and locking or tagging out energy isolation devices.”

Here again, overdoing safety degrades the original goal. If too many obstacles are involved, **workers may redistribute keys to rationalize work.**

The safety officer should keep in mind that zealous workers often tend to underplay real risks, while disinterested workers may use safety as a weapon against the employer. *In the end, there is no substitute for a thorough evaluation of the physical and operational situation, as well as of the personnel involved.*

Many simple methods can be used to increase safety in electrical work...

2.2.4. Safety in Power Networks

2.2.4.1. Transmission Network Maintenance

The maintenance of transmission towers and lines involves a group of linemen trained for this purpose. A large part of the work must be done while the system is energized, since the interruption of even a single High Voltage line would mean a substantial power deficit for the network [Elek, 1961].

One frequent maintenance situation involves the verification or replacement of ceramic and glass insulators on 735 kV lines. The insulators can occasionally lose their insulating skirt (glass insulators) or short-circuit (ceramic insulators). The technique used to detect the faulty units involves “buzzing” each insulator of a string in succession. This means that a metallic fork of the proper span is brought in contact with the bottom and top of an individual insulator. If the unit is bearing voltage, a spark is detected on contact. Its absence indicates that the unit is faulty (shorted).⁸

⁸ The worker is dressed in a conductive suit and holds the fork from the tower with a long “live-line stick”. When performing such a task, the

Another safety condition is that the worker not exceed a given limit of approach to the conductor, otherwise flashover may occur. The actual danger is not related to the steady-state voltage of the line, but rather to the occurrence of rare events such as switching surges or lightning strokes, which could occur while work is being performed. Such over-voltages are generally assumed to be 2-3 times the normal operating line voltage.

In special circumstances, a “bare hands” method can be used. In this method, the equipment consists of a bucket truck with an insulated boom. The bucket itself is fiberglass, but with a metal liner. The workers are lifted clear off the ground in the



bucket, and as they approach the conductor, a live-line stick is used to attach a metallic bond between the metal bucket and the energized line. The worker can afterwards proceed to work on the conductor as if it were at ground potential.

worker is subjected to a very strong electric field and would receive shocks when there is momentary interruption of the contact between worker and tower, unless protected by conductive clothing. Loose contact between tower and worker cannot be avoided if the worker is climbing the tower with insulating footwear or when the tower is touched or released by a worker standing on an insulated ladder or platform; therefore, conductive clothing is necessary. Shocks are eliminated using suits usually made of Nomex fiber mixed with stainless steel. Conductive footwear is also used. The ACGIH TLV manual recommends the use of protective clothing in all fields exceeding 15 kV/m.

2.2.4.2. Distribution Network Maintenance

The distribution network is much more extensive than the transmission network. Procedures are different according to whether the network is underground or overhead. The appearance of the overhead network is as presented in the *Distribution* section in Chapter 1. The underground network is laid out as in the following diagram.

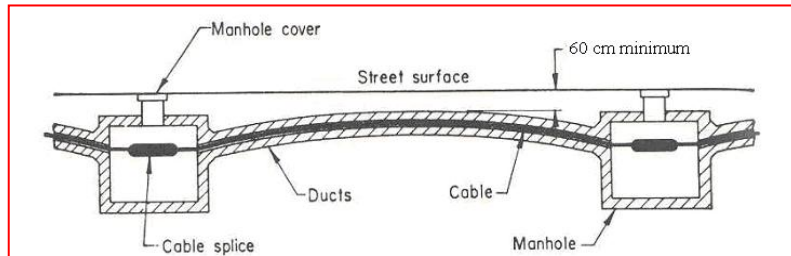

Maintenance of distribution lines (above or below ground) is preferably done with the power off.

It is often possible to isolate the location of a fault (for example, a fallen tree, or hardware defect) from the rest of the network by opening numerous switches. Then, maintenance can be done while interrupting power to only a small number of customers.

However, in order to increase the dependability of the service, live-line work may be necessary. The performance of work on live conductors is usually reserved for specific situations, as negotiated between union and management.

In the distribution network, two techniques are used for live-line work:

- rubber glove
- live-line stick

In the first case, the worker handles the live line parts while protected by *rubber gloves* acting as insulating barriers. The rubber gloves are usually protected mechanically by an exterior layer of leather, and are tested regularly for *insulation capacity* (CSA Standard Z259.4-M1979, Rubber Insulating Gloves and Mitts).

In the second case, line hardware is handled using non-insulating gloves (leather), but on the end of *live-line sticks*, long fiberglass rods which are kept carefully clean, so as to maintain their insulation properties.

Whatever the technique used, the worker handling live wires is usually above ground in a bucket truck with an insulating boom, such that “**double insulation**” is provided. This second level of protection can be unwittingly defeated if the worker is in contact with any grounded object.

A real danger resides in the worker’s blind trust in the presence of a second level of protection. In his eyes, this allows him to transgress safety rules relative to a first level of protection without harm.

Many accidents occur because a second unmonitored protection system, assumed present, was in fact absent.

2.2.5. General Safety Procedures

Hygiene procedures to avoid electrical accidents involve

1. specific equipment configuration (such as grounding of enclosures),
2. engineering design (dielectric insulation and current capacity),
3. maintenance of electrical equipment,

4. electrical work practices (padlocking, interlocks, warning signs, worker habits),
5. sensitization of workers to the presence of risk, in order to support safe work practices.

2.2.5.1. Equipment

- Voltmeters (previously checked for proper functioning on a known source) to verify whether conductors are energized. Beware of arcs created by high power circuits, should you mistakenly use the multimeter in its “Ohm” or conductivity position.
- Tools with *insulated handles*.
- *Face shield* when working on high power equipment (large current capacities) as intense arcs may occur.
- Removing metallic *jewelry*, watches, etc.
- Using insulating shoes.
- Insulated rubber gloves with protective leather gloves.



2.2.5.2. Labeling

- Identify prominently all *high voltage equipment*.
- Important electrical *interruption devices* should be clearly identified.

2.2.5.3. Awareness of Specific Dangers

- Opening of circuits feeding *large inductances* (transformers, coils, etc) generates large over voltages and arcs near the switchblades.

- Opening of *switches passing large currents* may create powerful arcs; insure that the switch is designed to cut the current safely.
- Be careful working in **wet** areas.
- *Failure scenarios of the equipment* should be considered. For example, in the event of thermostatic failure of an oven control, the size of the supply wire should be sufficient to avoid fire, and nearby materials should withstand the maximum possible temperature.
- Possibility of *capacitor explosion*, since some of these contain a liquid dielectric which may explode if overheated (due to an internal insulation fault).
- More people are killed by 120 V than by any other voltage.

Problem 22. Every year, over 1000 people are electrocuted in the US. What portion of these electrocutions result from contact with circuits at 600 V and less?

A - 1/8 B - 1/4 C - 1/2 D - 3/4

2.2.5.4. Specific Work Procedures

- Touch electrical wires **only after** measuring their voltage and grounding them.
- Ground capacitors after voltage interruptions, and guard against “dielectric return” voltages by placing a permanent ground connection.
- Tape the ends of uninsulated disconnected wires.
- At the critical moment of initial hand contact with a conductor, use only slight contact with the back of one hand, keeping the other hand without any contact, thus eliminating the possibility of one hand contracting on the conductor (is there another reason?), and discouraging the passage of current through the heart.

- Prevent operation by someone else of a circuit on which you are working.
- Do not stand in front of switch boxes while they are being operated (violent arcs are always a possibility).
- Consider damp concrete as an excellent conductor.

Work procedures are more difficult to control than equipment. There is a practice in a few industrial electricians which involves using finger contact instead of a voltmeter to discriminate between voltage levels of 110, 220, 440 and even 600 V! To be used in safety, this technique requires fingers rather well protected by callous skin, and control over the pressure applied. An accidental short-circuit during this procedure could be catastrophic on a low-impedance circuit, since a substantial arc could be formed. Also, it is possible that repeated local application of such currents could over time affect the tissues exposed, although no burn would ever be produced under a single exposure.

2.2.5.5. Arc-Flash

When there is a risk of dielectric breakdown in high power electrical systems, and consequently of powerful arcs, it becomes appropriate to protect workers approaching such equipment with special clothing designed to withstand arc-related heating (rated in calories/cm²). 40 cal/cm² equipment is illustrated. The equipment itself can be inspected using portable infra-red thermographers that are able to



detect abnormal hot spots on electrical equipment directly, or through openings or infra-red windows.

2.2.6. Fires due to Electricity



Note that Class C fire extinguishers should be used for energized electrical wiring, fuse boxes, circuit breakers, machinery and appliances. These extinguishers use non-conducting extinguishing agents such as CO₂, dry chemicals or halon.

A specification for electrical power circuits limits fire and shocks hazards.

Class 1 circuits: fire hazard but no shock hazard.

Maximum voltage: 30 V rms.

Maximum transferable power: 2500 W.

Class 2 circuits: neither fire nor shock hazard.

Maximum voltage: 30 Vrms or 60 V DC.

Maximum current: 5 A.

Maximum transferable power: 100 W.

Class 3 circuits: no fire hazard but shock hazard.

Maximum voltage: 150 V rms.

Maximum current: 5 A.

Maximum transferable power: 100 W.

2.2.7. Explosions due to Electricity

Electrical energy can ignite explosive materials [Cooper, 1989], specifically gases, and electric systems in hazardous areas must

1. include explosion-proof equipment and flame arresters if the explosion is to be *permitted*, or
2. eliminate sources of ignition or isolate them if explosions are to be *prevented*.

2.2.7.1. Area and Material Classification

When talking about explosion-hazardous materials in industry, the following vocabulary is used.

- **Class** defines the generic kinds of hazardous materials that may be present: flammable gases and vapors (I), combustible dusts (II), flyings or materials not normally in suspension in air (III).
- **Group** lists materials of similar hazard.
 - Group A:** acetylene is in this class because of its propensity to form copper *acetylides*.
 - Group B:** hydrogen, manufactured gas.
 - Group C:** ethyl-ether, ethylene, cyclo-propane.
 - Group D:** gasoline, hexane, naphta, benzine, butane, propane, alcohol, acetone, benzol, lacquer, natural gas.
 - Group E:** metal dusts.
 - Group F:** carbon black, coal, coke.
 - Group G,** flour, starch, grain dusts.

Groups A, B, and C are lighter than air.

- **Division** is an indication of the probability that a combustible or flammable concentration of the material

will be present: materials present in normal operation (1), materials present in the event of equipment failure (2).

For example, a gasoline pump is rated as a Class I, Group D, Division 1 within a specific volume surrounding it. The interior of spray paint booths and the exhaust ducts for painting and finishing are Class I, Division 1. Any area in which flammable anesthetics (cyclopropane, divinyl ether, ethyl chloride, ethyl ether, ethylene) are administered is Class I, Division 1.

Problem 23. Only one gas is in Group A, which one?

Problem 24. Why are copper acetylides dangerous?

Metallic dusts, Group E, because they are presumed to be conductive, provide a means of striking an arc as well as a combustible material.

Note that the penalty for over-classification of an area is severe, not only in equipment investment but also in permissible operating practices.

If an area respects standards for human health exposure, the limits for explosion dangers are satisfied by a large margin [Abbey, 1964]. Consequently, there should **not** be impressive banks of explosion-proof enclosures in control rooms or process areas where personnel are routinely present. Workers **should not** be routinely in Division 1 locations.

Solvent	Fire Limit % vol	Fire Limit PPM	Health Limit PPM	Ratio Fire/Health
Acetone	3.0	30,000	1,000	30
Amyl acetate	1.1	11,000	200	55
Carbon disulfide	1.25	12,500	20	625
Ethyl acetate	2.5	25,000	400	62.5
Ethyl alcohol	4.3	43,000	1,000	43
Hexane	1.2	12,000	500	24
VM&P naphta	0.92	9,000	500	18
Toluene	1.4	14,000	200	70

2.2.7.2. Electrical Triggering of Explosions

Just because an arc is visible does not make it ignition capable. There must be enough energy in the spark to propagate ignition. For mixtures of a given explosive gas with air, a certain concentration of the gas can be found at which the mixture is most easily ignited by the *minimum ignition energy*. The minimum ignition energy as a function of fuel-to-oxygen ratio for hydrogen and propane is depicted below.

Ignition is influenced by pressure, temperature, concentration of gases and other factors [Calder, 1983]. In practice, energy 60 to 100 times greater than the minimum ignition energy is

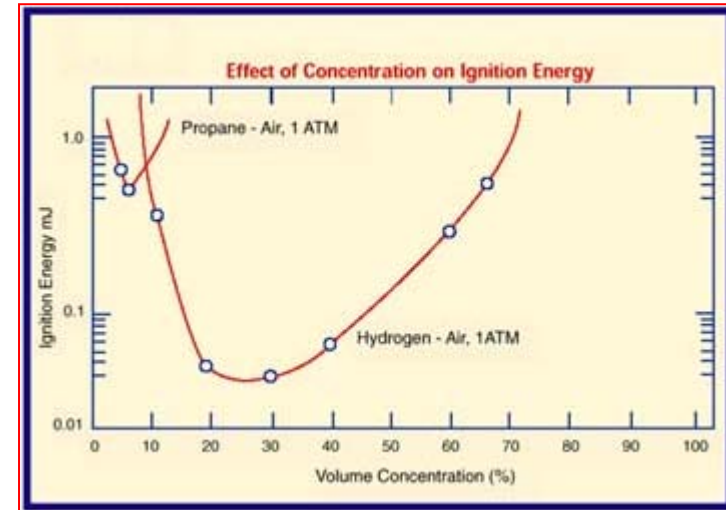

required for danger in a discharge to a human operator, for example (fibrillation).

Dielectric strength of air actually increases rapidly as gaps get to be smaller than 1 mm. At normal atmospheric pressure, the minimum breakdown voltage between electrodes in air occurs at 300 V. This implies that the electrodes are only 0.075 mm apart when the arc is struck. Because easily ignited substances like hydrogen-air mixtures have quenching distances of the order of 0.75 mm, at 300 V, the electrodes protrude substantially into the incipient flame sphere and conduct heat away from the ignition process. Because an arc will not jump the gap in a circuit below 300 V, it is necessary that the electrodes touch for the arc to develop and ignition to occur. Thermal losses are especially high in this case.

Any spark will cause combustion of a gas mixture. However, for the event to continue into an explosion, enough energy must be available to heat the layer surrounding the exploded

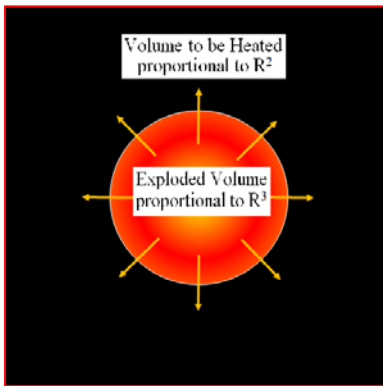

volume to explosion temperature. Since the amount of material exploding increases as the cube of the radius, and the amount of material to be heated as the square of the radius, once a minimum amount of the gas is ignited, combustion will be self-propagating (see figure). The energy required to ignite the

minimum initial volume is the *Critical Ignition Energy*.

In some cases, the Critical Ignition Energy can be reached even by static electricity. For example, the simple act of removing a wool shirt without first properly grounding a subject can generate energies of several millijoules. By going from 30% to 80% atmospheric humidity, surface conductivity of a material can increase by a factor of 1 million, which will discharge static electricity to ground.

The physics of arcs is complex, and the thresholds of ignition often refer to the mechanism of the ignition process, for example the closing of contacts in a capacitive circuit, or the opening of contacts in inductive circuits.

Problem 25. A capacitor has a value of 6600Ω at 60 Hz. What is the static voltage to which it should be charged if its energy is to equal the minimum energy of ignition of hydrogen (0.02 mJ)?

A table of Minimum Ignition Energies for various turbulent dusts is given below. If an object of a given electrical capacitance is charged electrostatically to a given voltage, an

equation ($E = \frac{1}{2}CV^2$) can be used to compute the energy content of a full discharge to ground.

Dust	Minimum Ignition Energy (Joules)	Relative Explosion Hazard
Alfalfa	.320	Weak
Cocoa	.1	Moderate
Corn	.040	Strong
Corn cob	.040	Severe
Corn starch	.020	Severe
Cotton linters	1920	Weak
Cotton Seed	.060	Strong
Grain, mixed	.030	Strong
Rice	.040	Strong
Sugar	.030	Severe
Wheat	.060	Strong
Wheat Flour	.050	Strong

Kennedy, Patrick M., and John Kennedy, Explosion Investigation and Analysis, 1990.

2.2.7.3. Prevention: Intrinsically Safe Wiring

Almost all intrinsically safe circuits require both current (metal film or wire wound resistors) and voltage (redundant Zeners and silicon-controlled rectifiers) limiting.⁹ The energy contained in a circuit will not only depend on voltage and current levels, but also on the inductance and capacitance of the supply circuits. The energy contained in these electrical component is expressed as $\frac{1}{2}LI^2$ for inductances and $\frac{1}{2}CV^2$ for capacitors.

⁹ Safety can be designed through analysis of circuit parameters, but may have to be complemented by testing in some cases.

Intrinsically safe wiring and hardware is incapable of releasing sufficient electrical or thermal energy under normal or abnormal conditions to cause ignition of a specific atmospheric mixture (CSA Standard C22.2-157).

Many of the methods insuring intrinsically safe circuits will depend on components such as transformers, current-limiting resistors, blocking capacitors and others. These elements must be tested for reliability.¹⁰

Intrinsically-safe circuits are *gas-group dependent*, that is, the design of a particular system depends on the particular energy of ignition allowable.

Intrinsically-safe circuits are supported in equipment by specific electrical operating limits, such as 4 to 20 mA at 24 V.

Problem 26. What are the two parameters which must be matched in the design of an intrinsically-safe circuit for a given combustible gas-air atmosphere?

2.2.7.4. Limiting Explosions using Special Housings

There are two main techniques used involving special housings: explosion-proof housings and pressurization.

2.2.7.5. Explosion-Proofing

If combustion is initiated in a gas, it propagates within the gas, but it may meet surfaces, such as metallic electrodes, which will draw heat from the flame rapidly, and quench propagation. If the propagation is to be independent from such quenching, the burning volume must be larger than the so-called

¹⁰ For example, the transformers in such circuits must have insulation levels of basically twice the working voltage, plus 1 kV between primary and secondary, and between windings and magnetic core.

quenching distance. The basic mechanism of thermal quenching, by which explosion-proof housings prevent explosions, is illustrated in the following figure.

Explosion-proof housings are sealed to contain a possible ignition, prevent the transmission of flammable material, and prevent pressure piling between two enclosures connected by a conduit. The housings are of robust construction, with heavy walls, wide flanges or threaded covers with more threads (5+) than required for the closure function alone.

Whatever gas would be allowed to escape would be cooled by passage through narrow straits. Finally, external surfaces of the system must not become hot enough to ignite the explosive mixture (below *auto-ignition temperature*). Of course, this technique is *gas-group dependent*. It has wide application for motors and process control equipment which operate at inherently high power levels.

2.2.7.6. Pressurization

In the case of a pressurized system (also known as *purging*), the objective is to exclude entrance into the enclosure of flammable materials that may surround the enclosure. The system is sealed to prevent loss of protective inert gas or air.

Type Z protection is capable of reducing classification within an enclosure from Division 2 to non-hazardous. Type Y protection reduces from Division 1 to Division 2. Type X

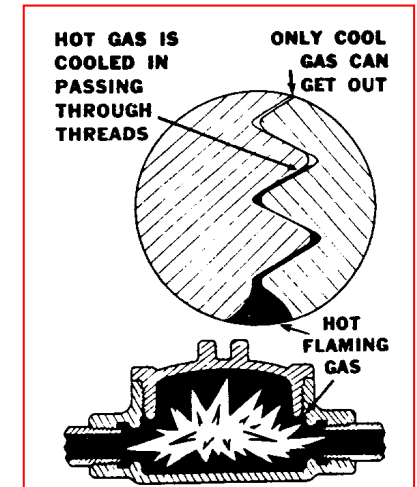

reduces the area within an enclosure from Division 1 to non-hazardous. In a Type X system, failure of the purging system should automatically be accompanied by de-energization of electrical circuits, to avoid disaster. Standards describe the requirements for each type of protection system in detail. Unlike an explosion-proof housing, the pressurization technique is NOT *gas-group dependent*.

Problem 27. What are the principles of explosion-proof housing and pressurized enclosures against explosions ?

2.2.7.7. Anti-Static Coatings

The generation of static electricity from the contact between two solid surfaces is not entirely understood, but it has been observed that free-radical scavengers appear to contribute to charge release and neutralization. As a consequence, anti-oxidants, such as vitamin E, can be integrated in small amounts in polymers to help dissipate electrostatic charges much faster than would happen otherwise [Baytekin, 2013], protecting electronic circuitry.

2.2.8. Safety in Special Environments

2.2.8.1. Mines

In specific environments such as *mines*, where **explosions and fires** can be quite catastrophic, stringent standards apply.¹¹

Briefly, use of electricity is prohibited in parts of a mine subject to sudden outbursts of **methane** (concentrations above 1.25% are considered dangerous). Methane gas is naturally produced during coal mining, and will explode when ignition is

¹¹ The details of these requirements can be found in CSA Standard C22.5-1977.

applied to any mixture containing 5-15% of it. The shock wave of such an explosion (as high as 688 kPa at a speed of up to 1 km/s) will raise a coal dust cloud. Fine coal dust is explosive when mixed with air at as little as 50 gm per cubic metre. Safety devices include transducers sensitive to methane, carbon monoxide, oxygen, and air flow, connected to computer systems.

Almost all materials which can be oxidized are potentially explosive when in fine powder form. The large surface per gram available to the action of oxygen allows these powders to behave similarly to volatile compounds.¹²

In a mine subject to explosive gas contamination, the trolley systems used for mineral transport must be interlocked with the *ventilation system*, such that in the event of a ventilation failure, operation of the trolley system is impossible. Work on live electrical circuits is strongly discouraged in mines. Hand-held equipment should not be supplied by voltages higher than 125 V, and mobile equipment should not be supplied by voltages higher than 1,100 V. Electric fans operating the ventilation should not be supplied from the same power source as electrical equipment within the mine (in case of service interruption due to a fault).

Grounding connections must under certain conditions be monitored for continuity. The grounding circuits must be included in special power cables with a current capacity not less than 60% of the largest power conductor.

There are special constraints on the electrical wiring in storage areas for explosive and blasting agents.

¹² In the second world war, some torpedoes were powered by aluminum powder. Aluminum powder is also used in fireworks: the flares that finish in a very loud “bang” and come from a very small, intense white source.

Transformers filled with a liquid that will burn in air cannot be installed underground. The units must be at least 60 m from explosive materials storage, and below 15 kV in voltage. Substitutes for normal mineral transformer oil used to be askarel (PCBs), but now silicone oil is favored.

PCBs are toxic¹³ but further, the children of the exposed show unusual dark pigmentation of parts of their bodies, bronze colored nails, recurrent conjunctivitis, teeth that fall out easily, global cognitive delay, and unusually high concentration of estrogen in boys [Rogan, 1995]. Swedish researchers have also uncovered a mechanism by which PCBs can cause serious damage to the lungs [Härd, 1995]. Uteroglobulin uses disulphide bonds to lock PCB metabolites inside itself, 1,000 times more tightly than the normal binder, progesterone, and collects in the lungs.

Other safety rules apply to motors, capacitors, switch gear, grounding conductors and configurations, lightning protection, electrical dynamite triggering circuits, etc.

Problem 28. In spite of the fact that the standards require that the grounding system of a mine should not have a resistance higher than 6Ω , the owner of a mine inappropriately instructs an electrical engineer to ground the mine's electrical system at a single point using a 1 m metallic rod inserted into rock known to have a resistivity of $1000 \Omega\cdot\text{m}$. What diameter of metal rod will the engineer have to use to satisfy this requirement ?

¹³ In the Yu Cheng incident, a machine that clarified rice oil accidentally leaked PCBs into the edible product, producing a range of debilitating and disfiguring symptoms including stomach pain, chemically induced acne and nerve inflammation.

2.2.8.2. Grain Elevators

The table below shows that coal dust and grain dust have a similar explosion propensity [Rogers].

Ignition comparison of coal and wheat flour dusts

	Ignition Temperature		Minima for Cloud		Max. Blast
	of Cloud	of Layer	[]	Energy	Pressure
	°C	°C	g/m ³	Joule	kPa
Coal	610	170	50	0.06	620
Wheat Flour	440	440	55	0.06	688

Over the years, there have been many explosions in grain elevators due to electrical discharges igniting both layers and clouds of grain dust. There have been 5 secondary explosions which resulted in 33 deaths, 69 injuries and 18 M\$ in damage between 1945 and 1979 in Canada.

The material handling system must produce the minimum of dust, and remove it as fast as possible.

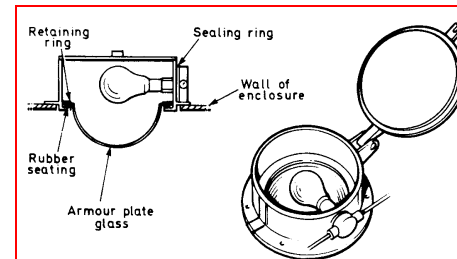

Dust-tight illumination system for silos and bins. Equipment should be maintained from *outside* the enclosure [Cooper, 1989].

Electrical equipment is contained in dust tight enclosures, and uses intrinsically safe circuits (see figure above).

Conveyors and silos are sources of static electrical discharges, and dedicated grounding circuits connected to a common ground are used to overcome these problems.

Sensitive earth leakage detectors limit the energy involved in faults to ground.

2.2.8.3. Offshore Rigs

Offshore gas and oil exploration is subject simultaneously to the Canadian Labour Code and CSA, Canada Coast Guard and IEC Standards. Flammable gases such as gasoline, butane, and natural gas are present in specific areas of the rig. Such areas are equipped with flameproof enclosures and intrinsically safe equipment. Visual and audible alarms are provided for environmental monitoring. The requirements in various safety documents from diverse sources do not agree in many instances. These difference must be resolved in a rational way.



2.2.8.4. Welding

Electric arc welding uses a small voltage (the maximum open circuit voltage of the welding machine may not exceed 80 V) because the arc is initiated by actual contact between the welding rod and the grounded piece to be welded. The electric arc is stable because the AC current provided by the welding machine is so large that the arc cannot cool quickly enough between cycles to lose its electrical conductivity. One must be prudent on construction or industrial sites where more than one machine can be in operation at a given moment. Some welding machines use DC. AC and DC should not be used on a common conductor. If more than one AC machine is

used on a single piece, care should be taken that the two machines are connected on the same electrical phase, and in the same instantaneous polarity. Failure to do so would drive very large currents through the machines, and could produce electrocution risks (160 V).

Electric arc radiation can be dangerous up to approximately 15 m. Welders should wear dark clothing to avoid reflections, and use darker rather than lighter filter shades.

Problem 29. It is normally safe to:

- A - wear light clothing when welding with the tungsten arc and an argon shield
- B - cool an overheated electrode holder in a bucket of water
- C - dampen your gloves slightly to help dissipate heat
- D - use a ground cable that is larger than necessary

Problem 30. You should use a dry insulating material underneath you when welding:

- A - over a metallic structure
- B - in a sitting or prone position
- C - both of the above
- D - neither of the above

2.3. Summary

Electrical circuit breakers, switches and fuses provide major components of electrical safety. The body's contact with live conductors can result in shock sensation, respiratory paralysis, ventricular fibrillation and electrical burns.

Important modules of electrical safety procedures are grounding, dielectric insulation, over-current protection, and double insulation. Door interlocks, padlocking, ground fault circuit interrupters, and special tooling are important aspects of electrical safety.

Electrical discharges stronger than the critical ignition energy may trigger explosions, therefore special circuits and systems are implemented to reduce the power of the circuits or to insulate sparks sources from flammable materials.

2.4. Bibliography

- Abbey 1964** D, Electrical Codes vs. Process Hazards, *Chemical Engineering*, August.
- Adjuvantis 1973** G, Dritsas C, Iordanidis P. An unusual occurrence of electric burns in a case of fatal electrocution. *Forensic Science* 2, 255-257.
- Antoni 1983** H. Function of the Heart, in "Human Physiology", Schmidt and Thews editors, Springer-Verlag, p. 358-396.
- Antoni 1970** H, Töppler J, Krause H. Polarization effects of sinusoidal 50-cycle alternating current on membrane potential of mammalian cardiac fibers. *Pflügers Arch.* 314 274-291.
- Baytekin 2013** H.T. et al. Control of surface charges by radicals as a principle of antistatic polymers protecting electronic circuitry. *Science*. Vol. 341, September 20, p. 1368. doi:10.1126/science.1241326.
- Bernstein 1983** T. Electrocutation and Fires involving 120/240 V Appliances. *IEEE Transactions on Industry Applications*, Vol. 1A-19, no 2, March-April.
- Bridges 1981** JE. An investigation of low-impedance low-voltage shocks. *IEEE Transactions on Power Apparatus and Systems*, vol PAS-100, no 4, 1529-1537.
- Calder 1983** W, Magison EC. Electrical Safety in Hazardous Locations, Instrument Society of America.
- Chapman 1994** CR, Morrison D. Impacts on the earth by asteroids and comets: assessing the hazard. *Nature* 94/01/06 367:33-39
- Cooper 1989** WF. Electrical Safety Engineering. Butterworths.
- Dalziel, 1941** CF, Lagen JB. Effects of electric current on man. *Electrical Engineering*, 63-66, February.
- Dalziel, 1972** CF. Electric shock hazard. *IEEE Spectrum*, vol 9, no 2, 41-50, February.
- Daniel 1988** RK. Pathophysiology of Surgical Treatment of High Voltage Electrical Injury, Canadian Electrical Association Report 165 D 286, September 1988.
- Daniel 1988a** RK, Ballard PA, Héroux P, Zelt RG, Howard CR. High voltage electrical injury: Acute pathophysiology. *J. Hand Surg.* vol 13A, No 1, pp 44-49.
- Daniel 1987** RK, Zelt RG, Kerrigan CL, Ballard PA, Héroux P. High voltage electrical injury of the upper extremity. American Society for Surgery of the Hand, 42nd Annual Meeting, San Antonio, Texas.
- Drezner 2009** JA, Rao AL, Heistand J, et al. Effectiveness of emergency response planning for sudden cardiac arrest in United States high schools with automated external defibrillators. *Circulation* 2009; DOI: 0.1161/CIRCULATIONAHA.109.855890. Available at: <http://circ.ahajournals.org>.
- Electric Shock Safety Criteria, 1985**. Bridges, ed. Pergamon Press.
- Elek, 1961** A, Simpson JW. Safe clearances and protection against shocks during live-line work. *Electrical Engineering*, 866-872, November.
- Geddes 1985** LA. The conditions necessary for the electrical induction of ventricular fibrillation, in *Electrical Shock Safety Criteria*, Pergamon Press, p.51
- Gold 1979** JH, Schuder JC, Stoeckle H. Contour graph for relating percent success in achieving ventricular defibrillation to duration, current and energy content of shock, *Am Heart J* 98:207
- Gonick 1990** L, Huffman A, The cartoon guide to physics, Harper Perennial
- Gourbiere 1986** E, Etudes des Brûlures Electriques à EDF sur une période de 10 ans, doctoral thesis of Université de Paris.
- Guderian 1986** R. *Lancet*, July 26.
- Haase 1959** E, Luvhan JA. Protracted coma from delayed thrombosis of basilar artery following electrical injury. *Arch. Neurol.* 1:195-202, August.
- Hard 1995** T, Lund J. *Nature Structural Biology*, November.
- Hauf 1985** R. Les accidents dûs à l'électricité. Premiers secours et démarches thérapeutiques immédiates. *Revue générale de l'électricité*, 11:854-67.
- Héroux 1985** P, Ballard PA, Daniel RK, Howard CR. Studies on Electrical Burns, Seventh Annual Meeting of the BioElectroMagnetics Society, 5 p, San Francisco.
- Héroux 1985a** P. Intra-Body Current Probes, in "Electrical Shock Safety Criteria", Bridges, Ford, Sherman, Vainberg, Editors, Pergamon Press, p. 215-221.
- Héroux 1986** P, Ballard PA, Daniel RK, Howard CR, Zelt RG. Experimental Investigation of Electrical Burns: Analysis of recorded Temperatures. 10th Scientific Conference on Electropathology, in "Beiträge zur Ersten Hilfe und Behandlung von Unfällen durch elektrischen Strom", Professor Rudolf Hauf, editor, pp. 147-180, Freiburg, W. Germany.
- Héroux 1991** P, Bourdages M, Dumas J, Huang F, Evans D. Electric Impedance Spectroscopy separates Thermal from Dielectric Damage in Electrical Burns. Transactions of the Bioelectrical Repair and Growth Society, Vol. 11, p. 46, Scottsdale, Arizona, September 29th-October 2nd.
- Héroux 1992** P. Thermal Damage: Mechanisms, Patterns and Detection in Electrical Burns. in "Electrical Trauma, the Pathophysiology, Manifestations and Clinical Management", Lee, Cravalho, Burke, Cambridge University Press, pp 189-215.
- Héroux 1993** P. Studies on the Pathophysiology of Electrical Burns and the Assessment of Tissue Vitality and Viability by means of Electrical Impedance, Canadian Electrical Association Report 165 D 286A, August 1993.
- Héroux 1994** P, Bourdages M. Monitoring living tissues by Electrical Impedance Spectroscopy, *Annals of Biomedical Engineering*, Vol. 22, Issue 3, pp. 333-342.
- Héroux 1993b** P, Bourdages M. Electrical Measurement of Edema, in "Electricity and Magnetism in Biology and Medicine", Martin Blank, ed., San Francisco Press,
- Héroux 1993c** P. Studies on the Pathophysiology of Electrical Burns and the Assessment of tissue Vitality and Viability by means of Electrical Impedance, Report 165-D-286A, Canadian Electrical Association Research & Development Dept., One Westmount Square, Suite 500, Montréal, Québec, H3Z 2P9.
- Hotte 1990** PW, Hotte VE. An Epidemiological Study of Electrical Accidents, Canadian Electrical Association Report 293 T 592, August 1990.
- Hu 2014** Y-F et al. Biological pacemaker created by minimally invasive somatic reprogramming in pigs with complete heart block. *Science Translational Medicine*, 6:245ra94.
- Hulsmans 2017** M et al. Macrophages facilitate electrical conduction in the heart. *Cell*. Published online April 20, 2017. doi: 10.1016/j.cell.2017.03.050.
- IEEE 1991**. Standard for Safety Levels with Respect to Human Exposure to Radio Frequency Electromagnetic fields, 3 kHz to 300 GHz. IEEE Standards Coordinating Committees 28, document C95.1-1991.
- JAMA 1992**. Guidelines for cardiopulmonary resuscitation and emergency cardiac care, 268:2171.
- Kerber 1981** RE et al. Transthoracic resistance in human defibrillation, *Circulation* 63:676
- Lee 1992** RC, Cravalho EG, Burke JF. Electrical Trauma: the Physiology, Manifestations and Clinical Management. Cambridge University Press, pp. 440.
- Lewis 1961** B and von Elbe G. Combustion flames and explosions of gases, Academic Press, New York

Moriarty 1987 BJ, Char JN. Electrical injury and cataracts. An unusual case. *WI Med J* 36:114-6.

Moss 2002 AJ. New England Journal of Medicine, March 21.

Peleska 1963 C. Cardiac arrhythmias following condenser discharges and their dependence upon strength of current and phase of cardiac cycle, *Circ Res* 13:21.

Reilly 1985 JP, Larkin WD. Réactions de l'être humain au courants électriques transtaires. Report 116-T-260, Canadian Electrical Association Research & Development Dept., One Westmount Square, Suite 500, Montréal, Québec, H3Z 2P9.

Riso 1975 DR. The incredible illustrated electricity book, Pathfinder publications, Boston, 1975

Rogan 1995 WJ. PCB's legacy. International Neurotoxicology Conference, Hot Springs, Ark. November.

Rogado 1976 AZ. Electrocution. *Headache* 16, 139-144.

Rogers JW. Electrical Safety in Hazardous Locations. Canadian Federal Enterprises.

Rossignol 1994 M. A comparison of mortality and case fatality rates of occupational injuries related to electricity and falls, *Chronic diseases in Canada*, vol 15, 1:12-16.

Squillace, 1989 SS. Exploring Electric Shock Hazards, LD&A, 21-24, July.

Tacker 1994 WA ed. Defibrillation of the Heart, Mosby.

Zelt 1986 RG, Ballard PA, Common AA, Héroux P, Daniel RK. Experimental High Voltage Electrical Burns: Role of Progressive Necrosis, *Surgical Forum of the American College of Surgeons*, vol XXXVII, 37:624-626 (October).

Zelt 1986a RG, Ballard PA, Héroux P, Daniel RK. Experimental high voltage electrical burns: the role of progressive necrosis. *Plast. Surg. Forum* 9:220-222.

Zelt 1988 RG, Daniel RK, Ballard PA, Brissette Y, Héroux P. High voltage electrical injury: chronic wound evolution. *Plast. Reconstr. Surg.* 82(6):1027-1041.

3. ELECTROMAGNETISM AND BIOLOGY	2
3.1. Classical Electrodynamics.....	2
3.1.1. Coulomb Force.....	2
3.1.2. Electric Field	2
3.1.3. Electric Field Calibration	3
3.1.4. Magnetic Field	3
3.1.5. Magnetic Field Calibration.....	5
3.1.6. Electric and Magnetic Field Calculations.....	5
3.1.7. Lorentz Force	6
3.1.8. Mobility of Electric Charges	6
3.1.8.1. Free charges.....	6
3.1.8.2. Bound charges	7
3.1.8.1. Dielectric Constant	8
3.1.9. Electrostatic Induction (E field)	10
3.1.10. Electromagnetic Induction (B field).....	13
3.1.11. Fields to Waves: Maxwell's Equations	16
3.1.12. Transmission of Electromagnetic Energy	16
3.1.12.1. Continuous Current	17
3.1.12.2. Oscillating Electric Field.....	17
3.1.12.3. Oscillating Magnetic Field	17
3.1.12.4. Travelling Waves	18
3.1.13. Electromagnetic Propagation	18
3.1.13.1. Emitting and Receiving Electromagnetic Waves	19
3.1.13.2. Confining Fields	19
3.2. Electromagnetic Environment.....	20
3.2.1. Natural Environment	20
3.2.1.1. DC Fields.....	21
3.2.2. Non-Natural Electromagnetic Environment.....	21
3.2.2.1. Ionization Limit.....	24
3.2.2.2. Modulation: AM, FM, PM	26
3.2.2.3. Pulsed Electromagnetic Fields	27
3.2.2.4. Electromagnetic Compatibility.....	28
3.3. Electrical Properties of Biological Materials.....	28
3.3.1. Characteristics of Tissues.....	28
3.3.1.1. Electrolyte Content.....	28
3.3.1.2. Resistive Structures and Membranes.....	29
3.3.1.3. Trans-Membrane Potentials.....	29

3.4. Biological Mechanisms of Electromagnetism.....	29
3.4.1. The “kT” problem	30
3.4.2. Delocalized charges: electrons and protons.....	30
3.4.3. Enzymatic Reactions	30
3.4.4. Interaction of Magnetic Fields with Water	31
3.4.5. DNA Conductance	31
3.4.6. A Variety of Mechanisms.....	31
3.4.7. Magnetic Sensors	32
3.4.8. Electronic Spin	33
3.4.9. Window Effects	34
3.4.10. Field Coherence.....	35
3.5. Appendix 1: Classical Electrophysiology.....	35
3.5.1. Polarization of Biological Membranes	35
3.6. Appendix 2: Bio-Electricity	36
3.6.1. Bioelectric fields in Development	36
3.6.1. Bioelectric fields in the Brain.....	36
3.6.2. Magnetic Sensing	37
3.6.2.1. Magnets for Positioning.....	37
3.6.2.2. Spin, Cytochrome and Magnetite	38
3.6.2.3. Human Magnetic Sensing	38
3.6.3. Electric Sensing.....	38
3.7. Appendix 3: Electro-Therapy	39
3.7.1. Bone Fracture and other Repairs	39
3.7.2. Electroconvulsive Therapy	40
3.7.3. Electropuncture and Electroporation	40
3.7.4. Deep Brain Stimulation	41
3.7.5. Treatment of Cancer	41
3.8. Appendix 4: Special Relativity and Magnetic Fields.....	41
3.9. Appendix 5: Dielectric Relaxation.....	42
3.10. Summary	43
3.11. Bibliography.....	43

3. ELECTROMAGNETISM AND BIOLOGY

The importance of electromagnetism to living systems can be inferred, for example, from the importance of *electrophoresis*, a powerful analytical tool used by biochemists, which is based on the mobility of biomolecules under electric fields.

The emergence of *therapeutic measures* (see Appendix 3: Electro-Therapy) based on electromagnetic induction has convinced many of the bio-activity of electromagnetic fields. There is hope that intelligent design of electromagnetic signals can act selectively on living tissues. Scientists are looking for an *electrical martingale* tied to living phenomena, which would widen therapeutic possibilities, beyond pharmacology or surgery.

3.1. Classical Electrodynamics

3.1.1. Coulomb Force

The interaction between electric charges at rest is described by Coulomb's law: two stationary electric charges repel or attract each other with a force proportional to the product of the magnitude of the charges, and inversely proportional to the square of the distance between them. Thus

$$F = \frac{1}{4\pi\epsilon_0} \frac{q_1 q_2}{r^2}$$

where F is in Newton, charge in Coulomb and distance in meter. ϵ_0 in the international system of units is equal to 8.85×10^{-12} Coulomb²/Newton.m².

The equation describes the relation between *two* charges. When many are present, we can handle the problem using the ***principle of superposition***. The *principle of superposition*

states that the force with which two charges interact is not changed by the presence of a third charge. The principle allows us to transform complex problems into a number of simple *two body* problems, and then to sum *vectorially* the forces computed to obtain the total force.

3.1.2. Electric Field

It is often desirable to know the force exerted locally on an individual electric charge resulting from interactions with all other distant charges. This can be done through the concept of the **electric field**, which conveniently integrates the effect of all "distant" charges into a single vector quantity which defines the actual force on the charge of interest.

Electric fields are measured in Volt per meter.

Once the electric field at a particular location is known, it is only needed to multiply the electric field by the value of the electric charge of interest to obtain the force exerted on it:

$$\vec{F} = \vec{E} q$$

E is in Volts per meter and q in Coulombs to obtain a force in Newtons.

Problem 31. A 100 V battery has, connected across its two terminals, a uniform resistive wire, 100 m in length. Which of the statements below applies?

A: The electric field in the wire is 1 V/m, along the wire.

B: There is no electric field in the wire since fields do not penetrate conductors.

C: The field in the wire is enhanced by charge movement much above the value of 1 V/m.

Although the concept of electric field is popular, the most modern explanation of the interactions of electrical charges, called Quantum Electro-Dynamics (QED), does away with the

concept of *fields*. Instead of fields, QED explains electrical forces by the emission and absorption of photons (grains of light) by these charges. QED is capable of describing all electromagnetic phenomena in nature, including the characteristics of the electron, to a precision of a few parts per trillion, and is consequently one of the most accurate physical theories ever built.

3.1.3. Electric Field Calibration

Electric fields are most conveniently established in a parallel plate configuration similar to a capacitor, because the field is uniform, and simply computed as the *voltage applied divided by the inter-plate distance*. Because of the edge effect, the field will only be perfectly uniform at the center of the plates.¹

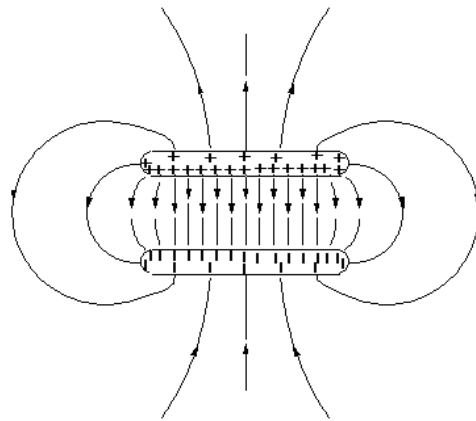

¹ For very precise work, this edge disturbance can be minimized by using an array of horizontal closed wires at the perimeter of the plates, and placed at regular intervals between the two of them. The potential distribution on the wires is then regulated by resistive dividers. This arrangement increases the volume within which a very accurate field is generated. When placing an object between the plates, some disturbance will be experienced in the field configuration because of the presence of the object itself (unless it has no conductivity and a dielectric constant equal to that of the vacuum). This disturbance is the same that the object would produce when subjected to any electric field, however, and does not need to be taken into account in the calibration. However, it is preferable to place the object to be calibrated midway between the plates so that the charge density on the plates is not

Electric Field of Parallel Plates

What is the electric field between two parallel plates 1 m² in surface, distanced by 10 cm and with a voltage of 120 Vrms between them?

$$E = \frac{V}{d} = \frac{120 \text{ Vrms}}{10 \text{ cm}} = 12 \frac{\text{Vrms}}{\text{cm}} \text{ or } 1,200 \frac{\text{Vrms}}{\text{m}}$$

3.1.4. Magnetic Field

The magnetic field is sometimes clad with an undesired aura of mystery (*personal magnetism*, etc).

First, there is absolutely nothing mysterious about the magnetic field: it just acts on electric charges to produce forces on them, only in a way slightly different from that of the electric field.

Second, in a strict sense, the magnetic field *does not really exist at all*: the magnetic field is actually only a calculation convenience, “Coulomb’s force in disguise”. In a discussion of the basic forces in nature, the magnetic force is always lumped with the electric force as the *electromagnetic force*.²

Magnetic fields are in practice established by *any flow of electric current*, such as the current flowing

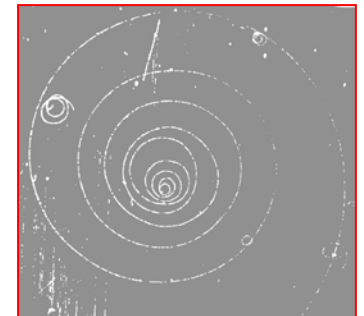

Hydrogen bubble chamber photograph of the path of a fast electron in a magnetic field. The electron enters at the bottom right. It slows by losing energy by ionization of hydrogen molecules. As it does so, its radius of curvature in the magnetic field decreases, hence the spiral orbit.

disturbed by the object’s presence. A corollary of this principle is that the plate spacing should be substantially larger than the vertical dimension of the object to be calibrated (~twice as large).

² One can demonstrate that the magnetic force is only *a way of looking at* the Coulomb force using Einstein’s theory of Special Relativity (see Appendix 4: Special Relativity and Magnetic Fields).

through an electrical wire. The magnetic lines of force form loops around the wire according to the *right hand rule*: if the thumb on your right hand indicates the flow of current, positive or negative, the direction of magnetic field lines is given by the curved remaining fingers (above). The *magnetic field density* at a distance r from a straight wire carrying a current I is

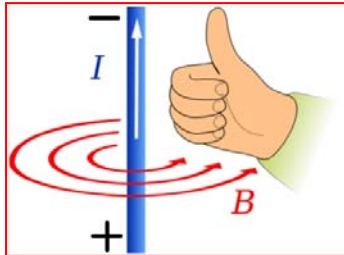

$$B = \mu_0 I / (2\pi r)$$

The unit for the magnetic field density (B) is the *Weber/m²*, or *Tesla*.³ μ_0 , the *magnetic permeability of free space*, $\mu_0 = 4\pi \times 10^{-7}$ Weber/Amp.m.

Because the permeability of air and of biological materials is so close to 1, there is little motive in hygiene to distinguish between *magnetic induction*, *magnetic field* and *magnetic field density*. The differences are of interest to physicists.

The origin of Earth's natural magnetic field is not completely understood. The Earth's outer core is at roughly 4800°C, fluid, and conductive. As Earth loses heat to space, the material goes in convection because of density changes, and because of the Earth's rotation. The electrical currents maintained within the molten metal, produce a surface static field of about 0.00005 Tesla (50 μ T).

³ The Tesla (kg/sec²xA) is quite a large unit. The world record for a non-destructive magnet is 100 Tesla for 15 msec.

Magnetic Field from a Wire

What is the magnetic field produced by a long straight wire carrying 100 Amperes at a distance of 1 m?

$$B(\mu T) = \frac{0.2 \times I(\text{Ampere})}{r(\text{meter})} = \frac{0.2 \times 100\text{A}}{1 \text{ m}} = 20\mu T$$

There are other units for the magnetic field:

$$1 \mu T = 0.796 \text{ A/m} = 10 \text{ mG} = 1000 \gamma = 0.01 \text{ Oersted}$$

Magnetic forces act in a peculiar way. The force F acting on charge q moving at velocity v in a magnetic field B is perpendicular to both magnetic field and speed v (diagram)⁴:

$$\rightarrow \quad \rightarrow \quad \rightarrow$$

$$F = q \ v \ \otimes \ B = q \ v \ B \ \sin \ \phi,$$

(\otimes represents a vectorial product).

B is the magnetic field in Tesla, v the speed in m/s, q the charge in Coulombs, F the force in Newtons, ϕ is the angle between field and speed.

The following relation can be used to compute the magnitude of the magnetic field from a straight wire carrying current:

$$B(\mu T) = \frac{0.2 \times I(A)}{r(m)} = \frac{20 \times I(A)}{r(cm)}$$

⁴ This is where the curious path followed by a charged particle traveling at a given speed and entering a constant magnetic field originates. Since the force acting on it is at right angles to its initial direction of motion, the path followed will be curved, according to the ratio of the particle's charge to its mass.

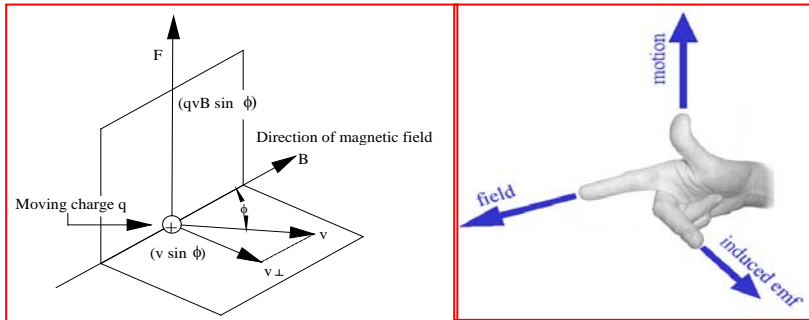

Problem 32. Calculate the magnetic field at a position centered between 2 parallel wires 1 m from one another, passing electrical currents of 1000 and 20 A in the same direction.

3.1.5. Magnetic Field Calibration

A known magnetic field is conveniently established using a 1 m² square flat support around which a wire is wound. The magnetic field at the center of the square is expressed as

$$B = 1.13 \times I \times N$$

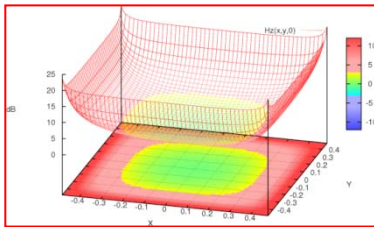

B is in μ Tesla, I in Ampere, N is the number of turns. The value of the field remains within 1% of the central value in a 6 cm radius.

The higher the frequency, the harder it is to establish electric and magnetic fields with reliability. As frequency increases, electromagnetic propagation takes on more importance, and electrical parasites make calibration more difficult. At radio and microwave frequencies, waves must be controlled using

confining structures such as Transverse ElectroMagnetic (TEM) cells and waveguides.

The design of antennas for high frequency emissions is a complex science, and substantial efforts are needed to optimize the design of a quarter-wave dipole helical coil used in a telephone handset, for example.

Magnetic Field Calibration

After winding 50 turns of wire on a square support 1 m on a side, I apply 1 A of ac current to the wire. What magnetic field is expected at the center of the support?

$$B = 0.90 \mu_0 I N = 0.9 \mu_0 \times 1 \text{ A} \times 50 = 56.6 \mu\text{T}_{ac}$$

This is comparable to the Earth's static magnetic field.

3.1.6. Electric and Magnetic Field Calculations

Electric and magnetic fields calculations can be performed using *Maxwell's equations* or their equivalents. In practical situations involving the electric field, one is usually presented with a number of conductive objects or boundaries which are at set electric potentials and/or are passing known current intensities. These limiting surfaces represent the *boundary conditions* of the problem.⁵

In the case of the magnetic field, boundary conditions are usually less important, because most materials allow magnetic field penetration.

⁵ At *conductive surfaces* the condition always exists that the *electric field* is **perpendicular** to the surface, as any electric field component parallel to the surface would be **counter-balanced** by a *charge distribution induced by the field* in the material.

Based on relatively simple physical principles, and with heavy help from computers, even relatively difficult field computations problems can be solved.⁶

3.1.7. Lorentz Force

The forces acting on a charge subjected to **combined electric and magnetic fields, such as in electromagnetic fields**, can be summed into a single force, the Lorentz force, and expressed as:

$$\vec{F} = q\vec{E} + q \vec{v} \otimes \vec{B}$$

As the equation suggests, electromagnetic fields in general can interact with materials through separate effects due to electric and magnetic fields. When the field is applied to materials, however, the ratio between the two fields can be altered, due to the particular material's properties.

So, if electromagnetic fields simply act to apply electric and magnetic forces to electric charges (such as ions in solution), why is the domain of electromagnetic fields bio-effects so controversial?

The answer lies in the fact that simple forces acting on systems as intricate as interacting charges and living organisms do not yield simple effects. The forces applied can vary in frequency over an extremely large range, 0 to 10²⁴ Hz.

At various frequencies, electromagnetic waves present with diverse personalities in the way they are propagated and attenuated in materials, and in their ability to ionize them. One

⁶ The methods used can be fairly complex, however. For example, the method used to assess exposures from radio-telephones is called the Finite Difference Time Domain method. This method requires a hefty workstation for a practical performance.

should be careful to apply the appropriate principles, according to the electromagnetic frequency domain under consideration (ie, ELF, RF, MW).

According to the Lorentz equation, both electric and magnetic fields can apply forces to electric charges in the body, and consequently produce effects. Whether the source of electromagnetic energy is electric or magnetic may not matter in some cases: effects on electron tunneling in tissues may have the same physiological effect independent of whether its origin is electric or magnetic. This notion is supported by the ability of both electric and magnetic fields to induce regeneration in bone (see Electro-Therapy section), although penetration of the fields in living tissues is different.

3.1.8. Mobility of Electric Charges

3.1.8.1. Free charges

When salts are put in solution, a large proportion of their molecules dissociate into positive and negative ions that can be drawn and separated at electrically polarized electrodes (*electrolysis*). Such charges are said to be **free**, and the movement of the ions in solution is the cause for the direct current **conductivity** of the solution.

Species	Mobility (m ² /V.sec)	Speed in 1000 V/m
Electron in metal	0.14	444 cm/sec
Ion in air	1.5 x 10 ⁻⁴	15 cm/sec
Na ⁺ in liquid	5.2 x 10 ⁻⁸	52 μm/sec
Protein in liquid	10 ⁻⁸ to 10 ⁻¹⁰	10 to 0.1 μm/sec

The motion of protein in liquids, the basis of *electrophoresis*, is dependent on such quantities as the pH of the solutions (*isoelectric point*). The most mobile charges of all are electrons in metals. They circulate so easily and with such rapid (10⁶

m/sec) chaotic motions that they behave collectively as a “degenerate Fermi gas” within the metal.

3.1.8.2. Bound charges

The application of electrical fields to non-polar atoms or molecules displaces their positive and negative centers of charge with respect to one another. The phenomenon is called *atomic polarizability*.

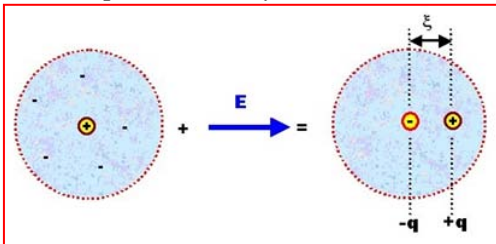

Furthermore, most molecules are polar, even without an applied field, that is, have *permanent* displacements of their positive and negative

centers of charge, “**permanent dipole moments**”, which are caused by the inherent quantum mechanical characteristics of the atomic species (*electronegativity and electropositivity*).

Such permanent dipoles respond to external electric fields.

Many common substances, among them **water** and HF above, have strong permanent dipolar moments: a single water molecule can be seen as a miniature capacitor. Alternating Coulomb forces can induce oscillation of the molecular dipoles inside these materials.

Microwave-frequency electric fields rotate polar molecules into a fast oscillation, and molecular friction inside the material converts this oscillation into heat, also called *dielectric loss*.

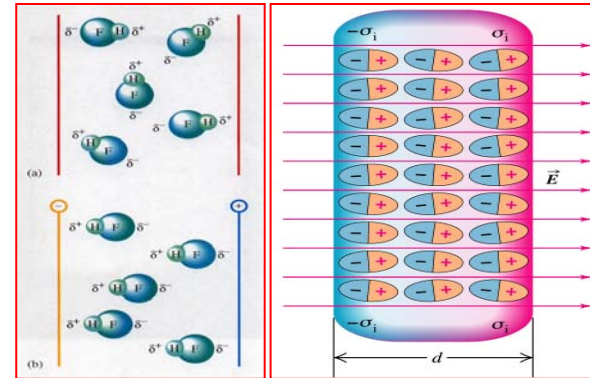

Hydrogen Fluoride molecules are initially randomly oriented (a), and then polarized (b) by an applied Electric Field. Right: a surface charge results.

In the same way that the mobility of free ions in solution dissipates energy (an electrolyte is heated as a current circulates through it), the oscillation of dipoles dissipates energy.

This is the basis of heating by microwaves.

Ice does not absorb microwaves because its water molecules are locked into crystals, and unable to rotate. Thus, one can boil water inside an ice block !

If electric fields can interact with dipoles, it is also true that dipoles (which are surrounded by their own electric field) can interact with each other. Polar molecules are attracted to a watery environment. Non-polars prefer a hydrocarbon surrounding. Soaps, detergents and mayonnaise provide both polar and non-polar segments.

ADHESION-----

Molecules can stick to one another because of their shape (“key and lock”).

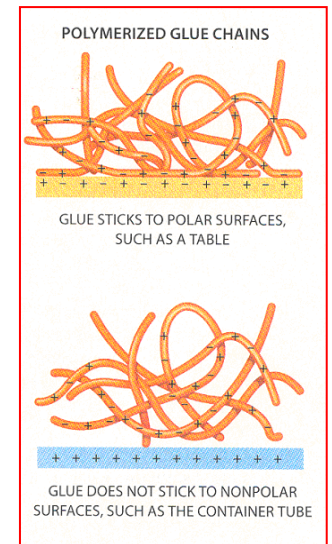

Atoms stick to one another through ionic bonds (electrostatic) or covalent bonds (instantaneous electrostatic) to form molecules. But how do atoms which have already completed their last electron layer to a quantum mechanical “magic number” (2, 10, 18, 36, 54, 86) and are of nearly spherical shape clump into small particles, as opposed to collapsing like sand castles?

Another **adhesion** forces in materials result solely from the *instantaneous interaction of dipoles*. In the same way that water can stabilize sand castles, the instantaneous interaction of dipoles allows adhesion. That force is designated as the *London interaction* in surface science. It is a major obstacle to the implementation of nanotechnology, making small parts stick irreversibly to one another. Familiar examples of the London interaction:

- The unexpectedly strong bond experienced between two highly polished, flat, parallel, metallic surfaces used as thickness standards, called Johannsen gauge blocks.
- The gecko foot. The animal walks on a type of Velcro made of very flat surfaces at the end of hairs on its feet. The adhesion is good as long as the flats are less than one atom away from the walking surface.
- Adhesion is strongest when surfaces are polar: having localized positive and negative electrical charge. Krazy Glue forms a polar plastic, and polar materials attract one another by bringing their oppositely charged regions as close together as possible. Since most ordinary surfaces are polar, Krazy Glue binds tightly to them. Its container, however, is made of polyethylene, a waxlike plastic that is almost completely nonpolar. Without localized charges to hold it in place, Krazy Glue barely sticks to the tube, and pulls away cleanly when you open the lid.

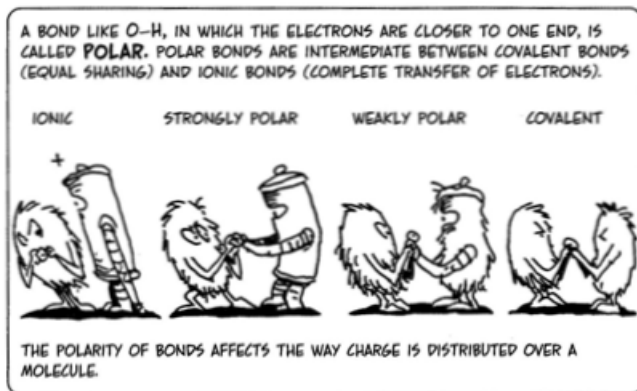

- Teflon: the *lack* of such dipolar interaction makes Teflon so hard to stick to. The substance presents to other molecules only a very small superficial density of dipoles (the material itself is cohesive because its molecules are very long chains of polymerized CF_2 units).
- In gases, the instantaneous interaction of dipoles is called the *Wan der Walls* interaction.
- If we look at the genetic code in detail, we find that whenever a single codon change does not yield the same amino acid, it still has a good chance of coding for one with similar hydrophobicity. All the codons with a middle U correspond to hydrophobic amino acids, which is critical in determining how the protein folds. Nature “knows” from evolution that level of hydrophobicity is critical to life, even at the most basic level. At least 2/3 of the time, point mutations will either leave the amino acid unchanged, or substitute another similarly hydrophobic amino acid. The genetic code itself is designed to protect hydrophobicity information, which really corresponds to a level of polarization. The genetic code is therefore optimized to conserve polarization specification, well ahead of other variables, such as electric charge.
- Enzyme action is dependent on extremely close proximity of atoms to one another, such as occurs in the strongly dipolar molecule of water (*hydrogen bond*). As atoms are squeezed together, proton (think pH) and electron transfers occur through tunneling, a physical process by which charged particles can overwhelm potential barriers that would normally prevent chemical reactions from occurring. Proton-coupled electron transfer underpins many biological reactions, and may occur as unidirectional or bidirectional, and synchronous or asynchronous, transfer of protons and electrons [Reece, 2009].

3.1.8.3. Dielectric Constant

A **dielectric** designates a polarizable non-ionic (non-mobile charges) material. When a dielectric is polarized by an electric field, this gives rise to a thin layer of bound charges on its surfaces, as shown in the diagram below. These charges are commonly exploited in many electrical devices.

If we polarize a flat plate capacitor with a voltage V , a charge Q will be transferred from one plate to the other according to

the physical dimensions of the capacitor (in the diagram below, 14 charges).

$$C = \frac{Q}{V} = \epsilon_0 \frac{A}{d}$$

C is in Farads, Q in Coulombs and V in Volt.

$\epsilon_0 = 8.85 \times 10^{-12}$ Coulomb/Volt (or Farad).

A is the surface of the polarized plates (m^2) and d the distance between the plates (m).

If a *polarizable material* with dielectric constant of 1.5 is then added between the plates (middle), the charges on the plates will be **half neutralized** by the charges of the polarizable material (diagram at right, middle, only 7 non-neutralized charges are left). The voltage source will then pump in more charges (bottom) to compensate (increasing the total charge from 14 to 14 + 7).

The more charges the dielectric can contribute, the more apparent *capacity* the system of plates will have. A material which contributes a large number of charges is said to have a high dielectric constant K, which is calculated as

$$C_1 = \frac{Q_1}{V} = K \epsilon_0 \frac{A}{d}$$

Dielectrics do not behave ideally under all circumstances. Once a dielectric has been polarized, it may retain some of its polarization for a while, even if the electrodes of the capacitor have been short-circuited. Therefore, capacitors may sometimes spontaneously partially recharge after being earthed with a grounding rod.

Problem 33. A capacitor has a capacitance of 10 μ Farads. How much charge must be removed to cause a decrease of 20 V across the capacitor?

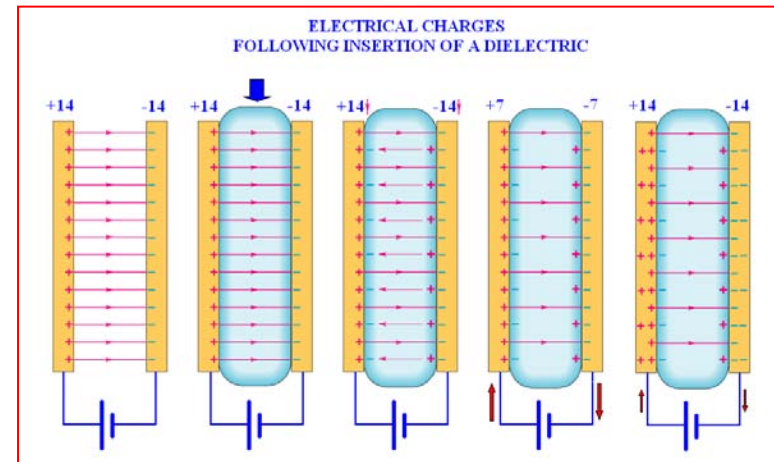

When a dielectric is inserted within a capacitor, the increased dielectric constant allows extra charge to be loaded onto the capacitor plates. The apparent capacitance value of the plates is increased.

Material	°C	K	Material	°C	K
Vacuum	-	1	Mica	25	3-6
Air (1 atm)	20	1.00059	Glass	25	5-10
Air (100 atm)	20	1.0548	Bakelite	27	5.5
Teflon	22	2.1		57	1.8
Polyethylene	23	2.25		88	18.2
Benzene	20	2.284	Neoprene	24	6.7
Hevea rubber	27	2.94	Germanium	20	16
Vinylite	20	3.18	Liq. ammonia	-78	25
Plexiglas	27	3.4	Glycerin	25	42.5
	47	3.6	Water	25	78.54
	76	3.92	Titanium dioxide (rutile)	20	173 ^ 86
	96	6.6	Strontium titanate	20	310
	110	9.9	$\epsilon_0 = 8.85 \times 10^{-12}$ coul ² /Nm ² (vacuum)		

The table lists the values of the dielectric constant of various materials. Note that when a material is exposed to an alternating electric field, its molecules can dissipate heat through having a net charge (electrophoretic movement), as well as through rotation related to their permanent dipolar moment.

Problem 34. Benzene and water are placed in a microwave oven. Benzene has a dielectric constant of 2.28, while water

has a dielectric constant of 78.54. If benzene had a heat capacity half as large as water, which of the two substances would heat up the fastest?

3.1.9. Electrostatic Induction (E field)

Alternating electric and magnetic fields each have their own way of transferring energy *without apparent contact*...

Alternating electric fields transmit energy to free charges, charged atoms or to molecules that have permanent electric dipoles. Electric fields can **circulate currents at a distance** (without contact) within any electrical conductor or dielectric.

In metals, free electrons will obey the applied field because of Coulomb's force. This is the basis of electron motion and **electrostatic induction**. Electrostatic induction tends to surprise people unfamiliar with electromagnetism, since electrical energy can be drawn from a conductor **without any apparent physical contact** with it [Glasgow, 1981]. The strength of this transfer of energy through electrostatic coupling is quantified in engineering by the concept of **capacitance**. Since the Coulomb force is inversely proportional to the square of distance, the nearer objects are to each other, the stronger they interact, i.e. the more *capacitance* they have to one another. If the concept of capacitance seems difficult to grasp, think of it as a numerical evaluation of "closeness" between objects. A capacitor of high value contains two large sheets of metal foil tightly rolled up and separated by only the thinnest dielectric.

Since any object in the vicinity of an alternating current line is capacitively coupled to it, it is raised to a specific electric potential, although no physical conductive (resistive) link may exist with the energized conductor.

IT WORKS LIKE THIS: CHARGE MOVES BACK AND FORTH IN THE CIRCUIT, ALTERNATELY CHARGING A PLATE, DISCHARGING IT, AND RECHARGING IT THE OPPOSITE WAY. THE CURRENT APPEARS TO CROSS THE GAP.

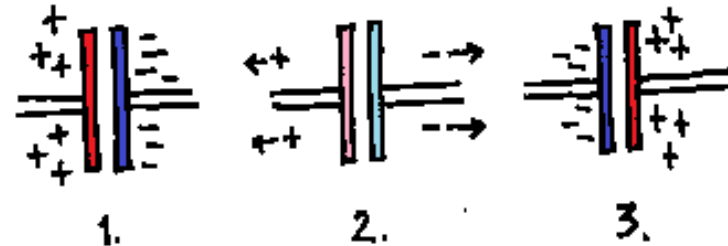

Capacitance of Parallel Plates

What is the capacitance between two 1 m² plates spaced 10 cm apart?

$$C = \epsilon_0 \frac{A}{d} = \epsilon_0 \frac{1 \text{ m}^2}{0.1 \text{ m}} = 10 \epsilon_0 = 88.5 \text{ pF}$$

What if the gap between the plates is filled with completely de-ionized water?

$$C = 88.5 \text{ pF} \times 78.54 = 6.95 \text{ nF}$$

In many practical situations, farmers raising livestock near high-voltage lines will experience productivity difficulties because such structures as insulated metallic fences can deliver **shocks** to animals. The animals themselves are coupled to ground potential by their conductive hooves, while the fence's wire is at a different electric potential because of electrostatic induction (also called *capacitive coupling*). The practical solution to this is to *ground carefully all metallic fences*.

Short circuit currents (mA) for objects in a vertical electric field E (V/m) at frequency f in MHz (ELF to 25 kHz) (Guy 1982)

Tractor	1.0 f E	Truck	9.6 f E
Car	1.47 f E	Man	0.26 f E
Bus	6.5 f E	100 m Wire	3.8 f E

This phenomenon has been a limiting factor in setting the level of allowable electric field intensity under high voltage lines. For instance, a large metallic truck placed below a high voltage line has a fairly high capacity to deliver current to a grounded human, or to other grounded objects such as a metallic gasoline canister. Energy can be delivered by a large object of given capacity-to-ground, taking into account as well the voltage to which it is charged.

There have been occasional instances in which ignition of gasoline occurred, shocks involving loss of control were delivered, and **pacemakers** were thrown into “reversion”, a fixed-rate pacing mode, because of electrostatic induction.

From a safety point of view, it is therefore important to understand how the interfering potentials are produced. The example that follows illustrates the parameters that influence such situations...

The man in the figure is standing on a perfectly insulating plate. Since the air and the plate are excellent insulators, the only electrical coupling is through capacitance. From field calculations that depend purely on geometry, the capacitance to ground of the man is **200 pF**, while his capacitance to the line is **1 pF**.

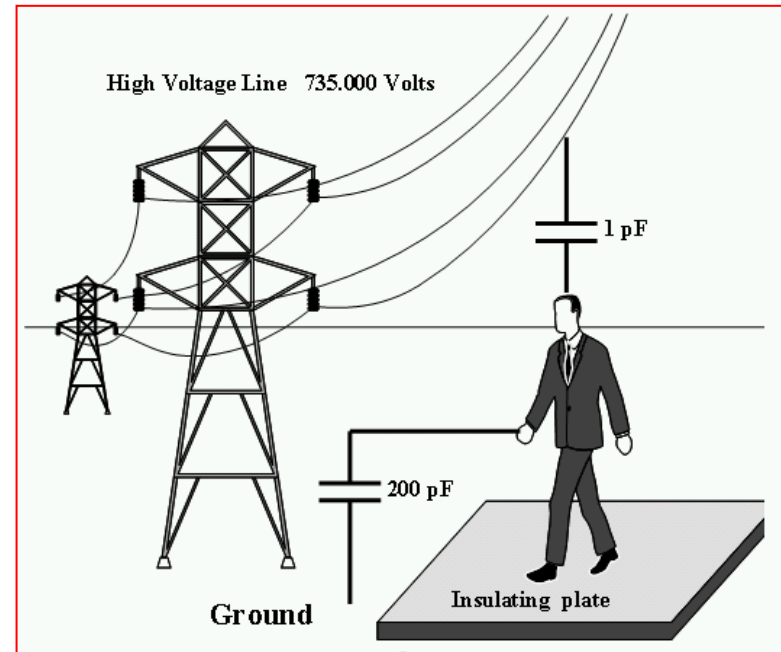

Q: At what electric voltage is our subject?

The calculation is straightforward:

$$\omega = 2\pi f \text{ (angular frequency equation),}$$

$$f = 60 \text{ Hz, and}$$

$$Z = 1/\omega C \text{ (capacitive impedance equation).}$$

Since impedances (Z) in series are added, the impedance of the circuit, illustrated on the next page, is:

$$Z = \frac{1}{\omega C_1} + \frac{1}{\omega C_2} =$$

$$\frac{1}{2\pi f \times 1pF} + \frac{1}{2\pi f \times 200pF} =$$

$$2,653 \times 10^6 + 13.3 \times 10^6 = 2,666 \times 10^6 \text{ Ohms.}$$

The man's potential can be computed by applying Ohm's Law to the circuit, resulting in:

$$V_{man} = \frac{V_{line}}{Z_{total}} \times Z_{man-to-ground} =$$

$$735,000 \text{ V} \times 13.3 \times 10^6 / 2,666 \times 10^6 = 3,666 \text{ V.}$$

Since this is a relatively high voltage, we may think that the man is in danger of being electrocuted, should he touch ground. This electrocution condition is illustrated in the figure below by closing of the switch (blue). However, the 60-Hz current that can be fed through the capacitive coupling from the line (C_1) is actually quite small:

$$I = \frac{V_{line}}{Z_{line-to-man}} = \frac{735,000 \text{ V}}{2,653 \times 10^6 \Omega} = 0.27 \text{ mA}$$

Our subject is in no danger from the 60-Hz current, this current being below perception level for almost all subjects.⁷

A second danger could exist if the subject was holding a gasoline canister and approached a grounded vehicle for refilling. A 200 pF man (C_2) charged to 3.66 kVrms may be at an instantaneous voltage (this is ac voltage) as high as 5.2 kV (= 3.66 kV x $\sqrt{2}$). If the canister made contact with the grounded vehicle just at the moment of maximum voltage, the energy discharged would be above 2.5 mJ, beyond the safe limit for hydrocarbon vapor/air mixtures.

An even more critical situation may arise if the human subject with the gasoline canister is grounded while a truck is insulated from ground potential (a truck's capacity is larger).

⁷ In Japan, the criterion used for limiting electric field levels under high voltage lines is the perception of a woman walking under the line while carrying an umbrella.

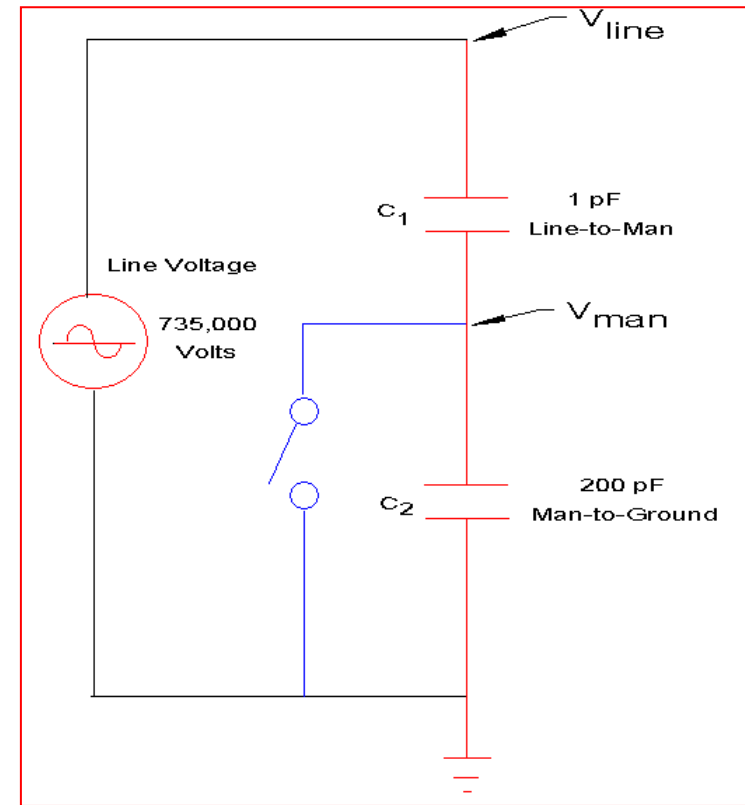

In conclusion, it is safe to walk under a 735 kV line from the standpoint of fibrillation thresholds, but it is not safe to refuel vehicles under them.

In practical situations, atmospheric humidity is often a consideration in the establishment of the electric potentials in such cases because even a small amount of surface water on tires can contribute resistance values comparable (in Ohms) to the capacitive impedances.

For example, if the man is wearing very dry leather boots, he may be insulated from ground; if the soles are wet, he is grounded.

Similarly, car tires are somewhat semi-conductive, and their resistivity can be influenced by humidity.

Problem 35. A worker wearing insulated boots is traveling in a truck when he hears a rattle. He stops the truck directly under a 735 kV line and circles the vehicle for inspection. The capacity of the man to the line is 1 pF, that of the man to the ground 200 pF. The capacity of the truck to the line is 12 pF and of the truck to the ground 2400 pF. The man suddenly touches the truck.

1. Calculate the current circulating between man and truck.
2. The worker sees that he will have to perform some work on the truck. He takes off his new boots because there is mud around the truck. Having done this, he touches the truck again. Calculate the 60 Hz current circulating between truck and ground after this action.
3. Can this current be felt?

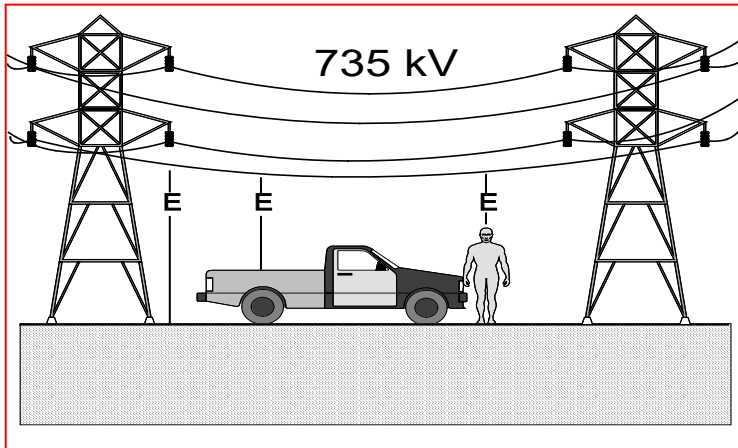

4. The worker actually moonlights in a part-time job in a circus as “Electric Man” and therefore has a very high threshold of fibrillation, 290 mA.

Knowing that the tonnage of the truck is equal to the capacitance of the truck in pF x 0.05, what is the heaviest truck

(in tons) that the worker could touch, in the preceding situation, without cardiac fibrillation?

Problem 36. A truck is parked directly below a transmission line. The voltage of the line is 315 kV. The capacitance of the truck to the line is 20 pF and 2000 pF to the ground. You happen to know that the energy stored in a capacitor in Joules is $\frac{1}{2} CV^2$. If the effective ignition energy is 60 mJ, is there a risk of refilling the truck by a grounded person holding a metallic container?

Problem 37. A worker has his left hand closed on conductor A and his right hand closed on conductor B. The resistance of the worker in this situation is 1000 Ohms, including contact resistance. Calculate the currents passing through the worker in the four situations described below. After obtaining a current figure, answer the specific questions associated with each situation.

Case	Conductor A	Conductor B	Question
A	110 V, 60 Hz	Grounded	What is the Risk?
B	1000 V, 60 Hz	995 V, 60 Hz	Any risk here?
C	Coupled by 10 pF to a line at 1 MV, 60 Hz	Grounded	Any risk here?
D	Coupled by 1 pF to a line at 1 kV, 600 kHz	Grounded	Can it be felt?

3.1.10. Electromagnetic Induction (B field)

Quantitatively, electromagnetic induction is governed by *Faraday’s law*, which states that the voltage induced in a turn of conductive wire of area A through which magnetic flux is passing is expressed as:

$$V_{induced} = \frac{d\Phi}{dt}$$

$$V_{induced} = A \frac{dB}{dt}$$

Where Φ is the magnetic flux (Weber), B is the magnetic flux density (Weber/m² or Tesla) and A is the area of interception. If, for example, the area A remains constant, it is the change in magnetic flux density dB/dt which determines the induction.

The voltage induced is sensitive to both the magnitude of the change and the speed of the change. If the magnetic flux density B was a sine-wave (as occurs at 60-Hz in the electrical power circuit),

$$\frac{dB}{dt} = 2\pi f k \cos(2\pi ft), \text{ and}$$

$$V_{induced} = \frac{d\Phi}{dt} = 2\pi f Ak \cos(2\pi ft)$$

Since $V_{induced}$ is proportional to f, **higher frequencies tend to induce electromagnetically more strongly.**

Electromagnetic welders, for example, sometimes operate at higher frequencies in order to increase the strength of the *electromagnetic coupling* and so the amount of energy delivered to the piece being heated.

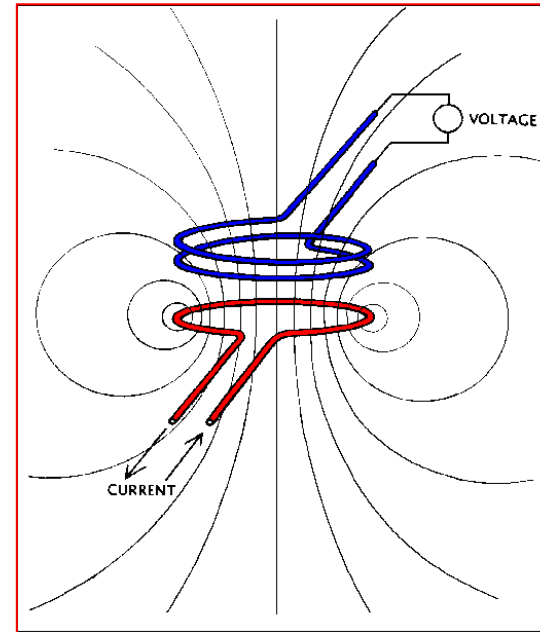

The *primary* coil (red) carries a current. Its magnetic lines of force intercept a second coil, the *secondary* (blue). If the number of lines of force in the *secondary* changes, either from a change in *primary* current or from a rotation of the *secondary*, a voltage is induced in the *secondary*. This phenomenon is the foundation of transformer and electric alternator action [Coltman, 1988].

A consequence of the induction equation above is that if a magnetic field pick-up coil is rotated in the earth's static magnetic field in such a way that its enclosed area includes fewer or more magnetic field lines, an electromotive force will be induced in the coil, and a signal detected.

A critically important application of electromagnetic induction is the large utility generators coupled to water-driven turbines supplying electricity to our cities.

Problem 38. A low-frequency (60 Hz) field meter can be used with a doughnut-shaped transducer to measure the power magnetic fields in the environment. Is it possible with such a device to find the orientation of the geomagnetic field from numerous measurements performed with the doughnut in various fixed positions? Why?

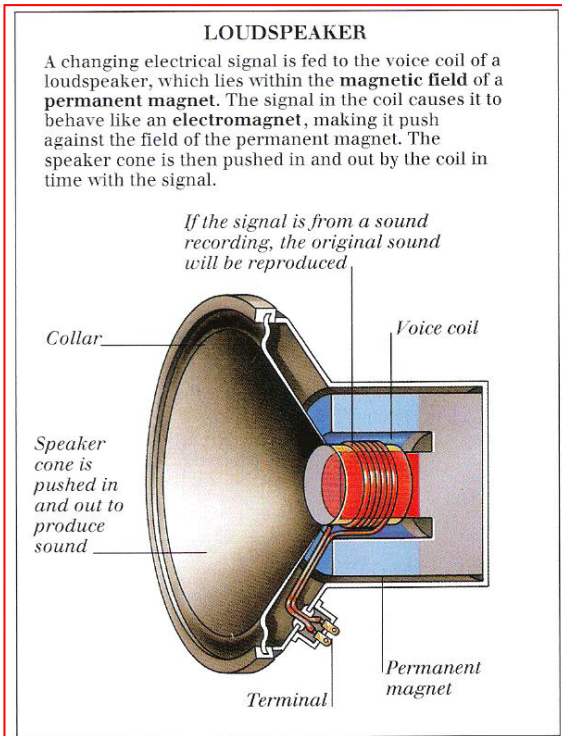

The sun's coronal ejections strike the Earth and cause rapid fluctuations in our planet's magnetic field. This was first noted in the 1840s when equipment connected to long-distance telegraph lines sometimes sprang to life, even though they were not connected to batteries. Modern

technology has installed many types of long conductors on the planet: power lines, communications lines, pipelines, etc. In the case of a major geomagnetic storm caused by a solar flare, utilities must quickly disconnect their equipment, otherwise damage could occur to the high voltage network's transformers. Some of the units are so large and complex that

delivery delays on replacements are as long as a year, and so it could take a long time to restore a damaged electrical grid.

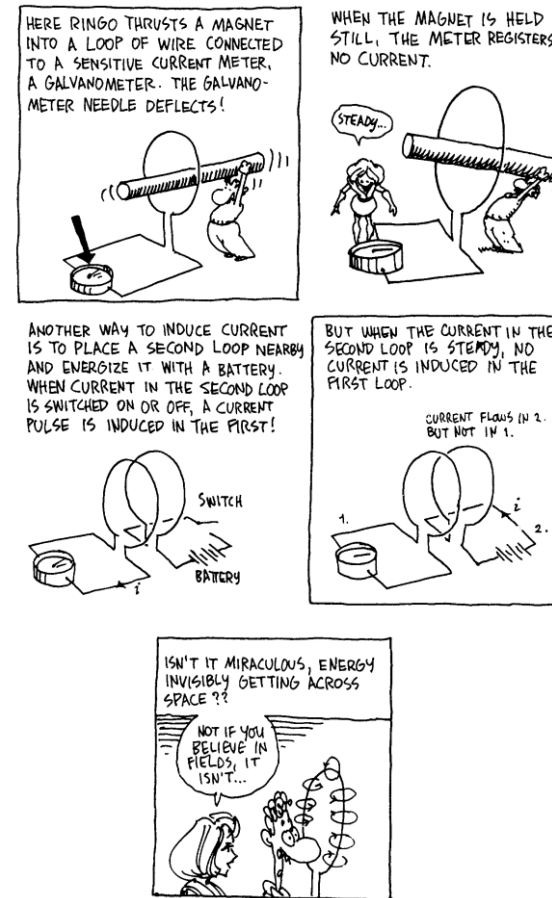

[Gonick, 1990]

3.1.11. Fields to Waves: Maxwell's Equations

$$\oint \vec{E} \cdot d\vec{A} = \frac{Q_{enc}}{\mu_0} \quad \text{Gauss's Electric Law}$$

$$\oint \vec{E} \cdot d\vec{s} = - \frac{d\Phi_m}{dt} \quad \text{Faraday's Law}$$

$$\oint \vec{B} \cdot d\vec{A} = 0 \quad \text{Gauss's Magnetic Law}$$

$$\oint \vec{B} \cdot d\vec{s} = \mu_0 I + \epsilon_0 \mu_0 \frac{d\Phi_E}{dt}$$

Ampere-Maxwell's Law

From the experimental observations of early investigators of electricity like Faraday, James Clerk Maxwell deduced 4 compact equations describing the behavior of electromagnetic quantities.

Gauss's Electric Law: states that electric field (E) lines spread out from positive electric charges, and converge on negative electric charges according to the charge enclosed (Q_{enc}) within a surface (A).

Faraday's Law: already familiar to us (section 3.1.7), electric field (E) lines curl around *changing* magnetic flux (Φ_m).

Gauss's Magnetic law: there are no magnetic charges, as magnetic field (B) lines always form closed, continuous loops.

Ampere- Maxwell's Law: magnetic field lines curl around electric currents (I), and, to account for current flowing through a capacitor, changing electric field flux (Φ_e).

Note that $B = \mu H$ ($\mu \sim 1$ in non-magnetic materials), therefore B takes into account the contribution of a material with relative magnetic permeability μ exposed to magnetic field H.

Light's index of refraction (n) is related to the relative (to vacuum) values of permeability and dielectric constant, as $n = \sqrt{\epsilon\mu}$.

Maxwell's equations are remarkable in the scope of their applications: they seem true under all circumstances, everywhere, from the scale of elementary particles (quantum electrodynamics) to that of astronomy.

3.1.12. Transmission of Electromagnetic Energy

An important property of electromagnetic fields is their ability to carry energy, either in small amounts (for the purposes of telecommunications) or in large amounts (alternators, motors, heaters).

EMFs are of extraordinary practical use because the transport of energy using electromagnetism - at close to the speed of light - is easy. Compare power being supplied at household appliances to the laborious process of distributing heating fuel. It is work intensive to transport chemicals, and even more so at the speed of light !

From the point of view of hygiene, propagation of EM energy is important, because it determines how EMFs penetrate human tissues.

There are four mechanisms by which EM energy can be transported...

3.1.12.1. Continuous Current

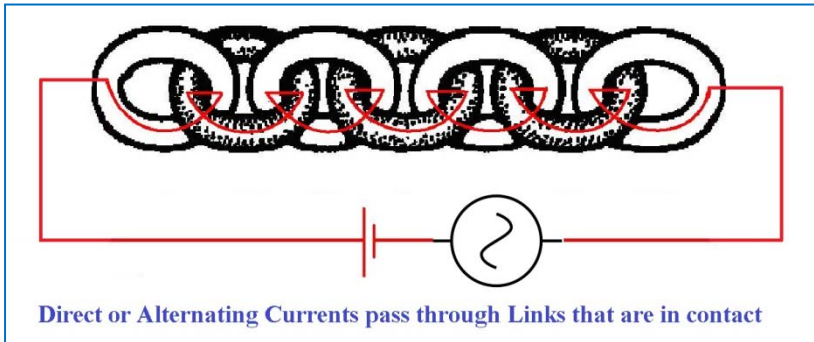

This first technique is similar to the one used for dc or ac (60-Hz) power transmission. A *source* (battery or alternator) propels electrons along a conductive circuit. In this example, the circuit is made of metallic links in contact, copper or iron, and electrons can travel from one link to the other. This method is dependent on Gauss's Electric Law.

3.1.12.2. Oscillating Electric Field

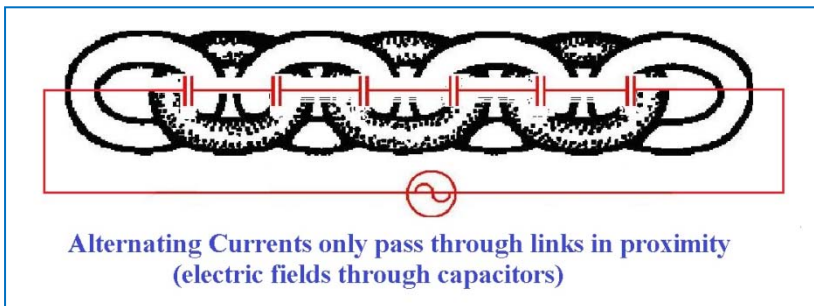

What would happen if the chain links were not touching one another, as shown above? Would energy still be able to flow through the circuit? That depends on whether the sender is a dc source or an ac source. In the case of an ac source, energy will

be able to cross the circuit through the capacitive couplings between adjacent links in the chain, as symbolized in red. We designated this mechanism "Electrostatic Induction" in 3.1.6.

Because propagation of energy is here dependent on a variable electric field, one must invoke Ampere-Maxwell's law to explain the phenomenon.

3.1.12.3. Oscillating Magnetic Field

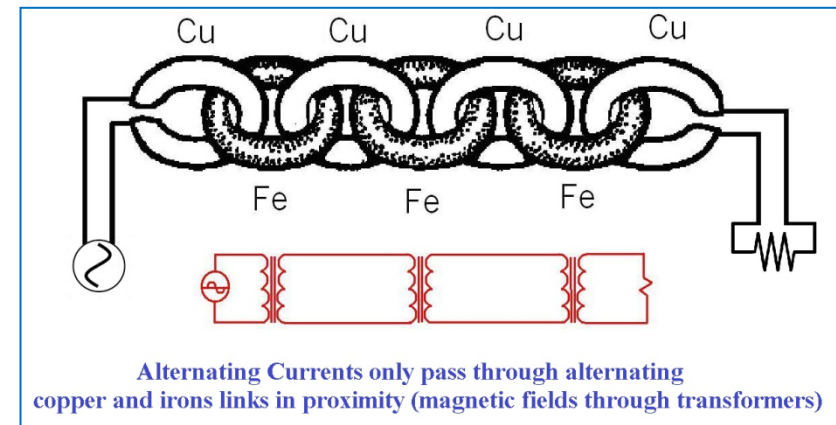

Still another method exists for energy propagation along the link, this time based on Faraday's and Gauss's Magnetic Laws, which we previously called "Electromagnetic Induction". Imagine that the links in the chain are alternately made of copper (Cu) and iron (Fe), as shown above. The oscillating source at left passes current through a single loop of copper (the first link). This produces a magnetic field which is picked-up by the second link made of magnetizable iron. The iron link is in turn capable of inducing a current in the copper link to the right of it, and so on. Each of the iron links acts as a transformer core, allowing power to flow through the chain, and to the load at right.

3.1.12.4. Travelling Waves

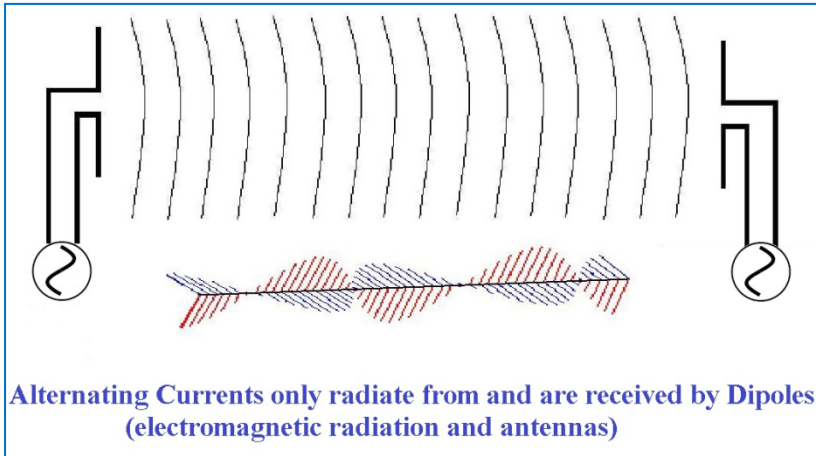

The previous cases of transmission of oscillating electric and magnetic energy depend on the fields near capacitors or inductors to support propagation. The method above depends on no physical support, allowing energy to propagate through space like waves on a water pond. It was the last discovered, and led to radio (“wireless”) applications.

3.1.13. Electromagnetic Propagation

From Faraday’s and Ampere-Maxwell’s laws in differential form (below), if the general field variables B and D ($D = \epsilon_0 E$) are explicated as harmonic functions ($\sin \omega t$) which have simple time-derivatives, one obtains:

$$\vec{\nabla} \times \vec{E} = -\frac{\partial \vec{B}}{\partial t} \rightarrow \vec{\nabla} \times \vec{E} = -j\omega \vec{B}$$

$$\vec{\nabla} \times \vec{H} = \vec{J} + \frac{\partial \vec{D}}{\partial t} \rightarrow \vec{\nabla} \times \vec{H} = \vec{J} + j\omega \vec{D}$$

In free space, the current density J is zero. The two equations above can be combined to give two second order differential equations:

$$\nabla^2 \vec{E} + \omega^2 \mu \epsilon \vec{E} = 0$$

$$\nabla^2 \vec{H} + \omega^2 \mu \epsilon \vec{H} = 0$$

If then one sets $c = 1/(\mu\epsilon)^{1/2} = 3 \times 10^8$ m/sec, the equations take the shape of wave equations describing propagation through space with speed c.

$$\nabla^2 \vec{E} + \left(\frac{\omega^2}{c^2}\right) \vec{E} = 0$$

$$\nabla^2 \vec{H} + \left(\frac{\omega^2}{c^2}\right) \vec{H} = 0$$

Maxwell’s equations also allow us to deduce that the ratio of amplitude between E and H is

$$\frac{E}{H} = \sqrt{\frac{\mu_0}{\epsilon_0}} = 377 \text{ Ohm}$$

The two fields are at right angles to each other, and to their direction of propagation, and in phase with one another for the case of a plane wave (illustration below).

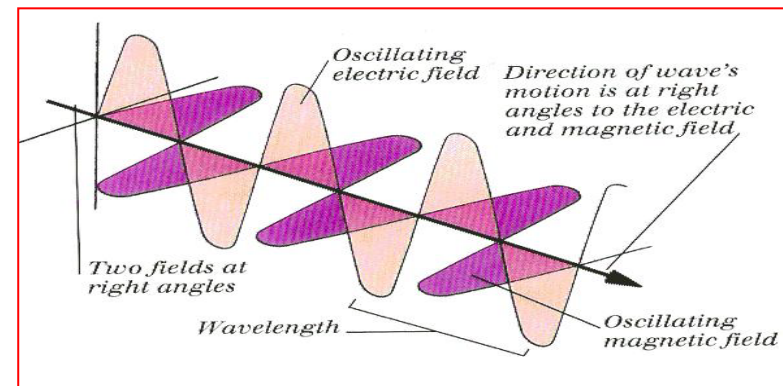

3.1.13.1. Emitting and Receiving Electromagnetic Waves

In the diagram above involving sender and receiver, a dipole (red) is used to radiate EM waves, and another dipole to receive them.

Without focusing, EM radiation *emitted* from a dipole matched in size to its broadcast wavelength is like a simple doughnut (below, and as shown in the section on *Dipole Antennas* in Chapter 5), and propagates in most directions.

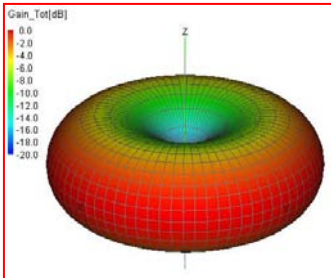

When the frequency is *not* matched to dipole length, the emission pattern becomes quite complex.

But waves can be focused using parabolic reflectors, or waveguides to confine the radiation.

A *receiving* dipole distorts an otherwise uniform local EM field, as illustrated at right, extracting energy (ie, radio signal) from the field in the neighboring space.

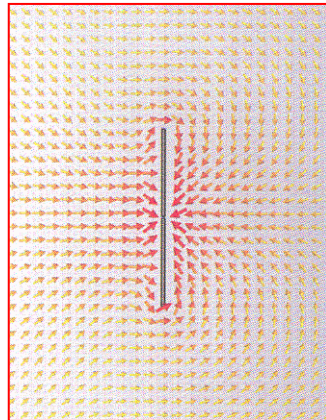

Higher frequencies have better propagation properties than frequencies below the “radio” or RF range. Indeed, the transmission of electromagnetic energy across free space was initially discovered as a phenomenon related to

switching, because the action of switching currents on or off generates relatively high frequencies.

3.1.13.2. Confining Fields

The electric and magnetic fields generated around conductors interact readily with other objects, so it is sometimes wise to confine two opposing fields in a restricted region of space. This allows the fields of each conductor to neutralize each other, and, as a bonus, also excludes outside electromagnetic influences.

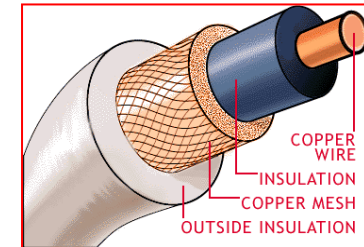

Coaxial cables achieve this by using a central copper conductor surrounded by a copper mesh cylindrical shield, restricting the field to the cable itself, rather than letting it escape into space. This allows the coaxial cable to be efficient in energy transmission from dc up to hundreds of MHz.

Occasionally, objects radiate energy in less controlled fashion, for example when devices are designed in industrial production for heating objects. Such sources have what is called a

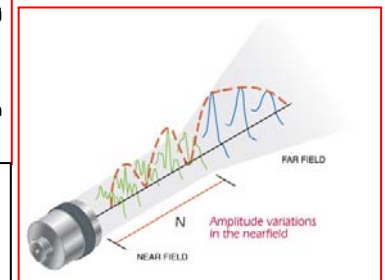
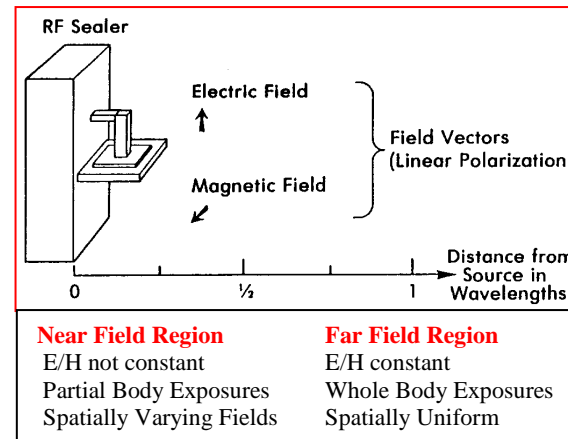

near field, a region where neither the amplitude ratio nor the phase between fields are in a fixed relation (377Ω) as described above. These situations are illustrated for the cases of a RF sealer (left) and transducer (right).

3.2. Electromagnetic Environment

3.2.1. Natural Environment

One of the largest objects in the night sky is the Milky Way. Using Chromoscope (<http://gleamoscope.icrar.org/gleamoscope/trunk/src/>), you can see a succession of different images in false color, depending on whether you are using (from the top down)

- ✚ Gamma Rays,
- ✚ X-Rays (hot shot gas),
- ✚ Visible Light (hydrogen α , 656.28 nm),
- ✚ Infra-Red (warm dust),
- ✚ Micro-Waves (including cosmic background radiation from the Big Bang in the periphery) or
- ✚ Radio Waves (electrons spiraling around magnetic fields).

This illustrates how frequencies of the same radiation interact differently with matter.

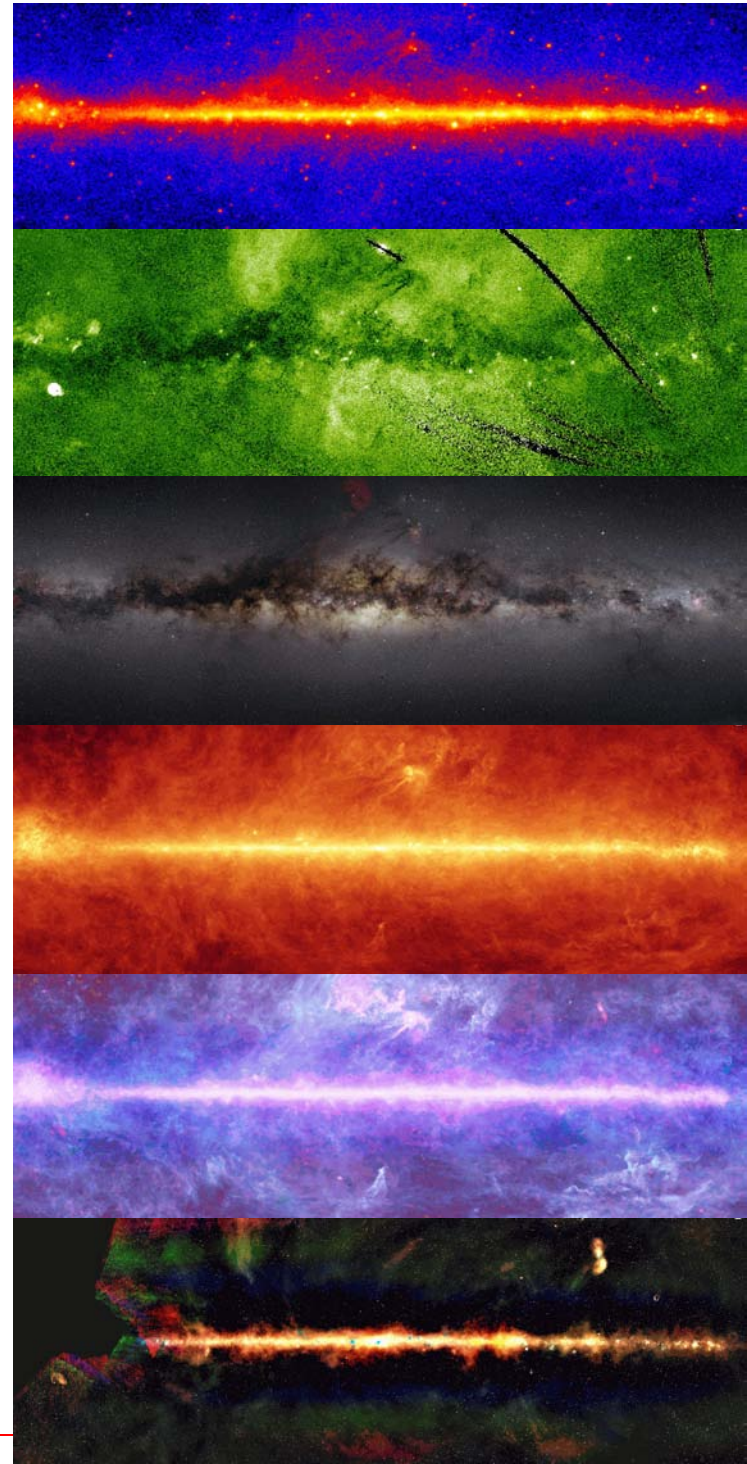

3.2.1.1. DC Fields

Substantial static fields have been present in the natural environment for a long time: the geomagnetic field (50 μ T), and the fair-weather electric field (130 V/m). Because life evolved in the presence of substantial natural fields, artificial dc fields in isolation are only a small concern from the health and environmental points of view because they are often small compared to natural fields. Also, static fields do not induce at a distance, from Maxwell's Equations.

The biological effects of static electric or magnetic fields *in isolation* will only be briefly mentioned below.

DC transmission lines are becoming more common in the world. Such large lines have static magnetic fields (20-30 μ T) comparable to Earth's magnetic field. The static electric fields near large DC lines are higher than natural (20 kV/m), but do not seem to pose health problems [Haupt, 1984]. They are also relatively easy to shield against. Perhaps of some mild concern is the air ion concentrations large DC power lines generate [Hendrickson, 1986].

Some modern applications generate exposures much larger than the natural ones. Magnetic levitation passenger cars where riders are exposed to ~ 50 mT [Dietrich, 1992] and Tokamak fusion reactors, where operators are exposed to ~ 45 mT [Tenforde, 1983]. One medical diagnostic application using large static magnetic fields is becoming widespread: nuclear magnetic resonance imaging (2 T+).

Although static magnetic fields are unable to induce currents in a strict sense, movements of the exposed subject or some

*physiological mechanisms implicating charge transfers within the subject may be susceptible to large static magnetic fields*⁸.

Static magnetic fields are most commonly measured using the *Hall effect*. This involves the transverse difference of potential measured across a piece of material passing electric current. The difference of potential is induced by the presence of a magnetic field, in accordance with Maxwell's equations. The shielding of static and lower frequency magnetic fields can be achieved with ferrous or special magnetic metals.

3.2.2. Non-Natural Electromagnetic Environment

Use of the electromagnetic spectrum has expanded with technology. In the 1920's frequencies above 1.2 MHz were considered inaccessible. By the late 1930's, the frontier of the spectrum had moved to 100 MHz, when Edwin Armstrong broadcast the first FM transmission from the Empire State Building in New York. In the 1970's, a few pioneers were constructing experimental apparatus that created energy at 20 GHz, followed by the first K_u band satellite tests in the 1980's. K_a band (26-40 GHz) as well as the 71-76, 81-86 and 92-95 GHz bands are used for high-speed microwave data links. The upcoming Wi-Fi standard IEEE 802.11ad will run on the 60 GHz (V band) spectrum with data transfer rates of up to 7 Gb/s.

⁸ Sensitivity to static magnetic fields is present in the orientation behavior of a diverse group of animals, which includes whales and pigeons (Appendix 2). The mechanisms of interaction can be electromagnetic induction as the animal moves through the field (sharks), interaction of the field with magnetic material (magnetotactic bacteria and mammalian brain, see Appendix 2) or free radicals in the organism. There are reports of large static magnetic fields affecting the growth of bacteria, and enzyme activity.

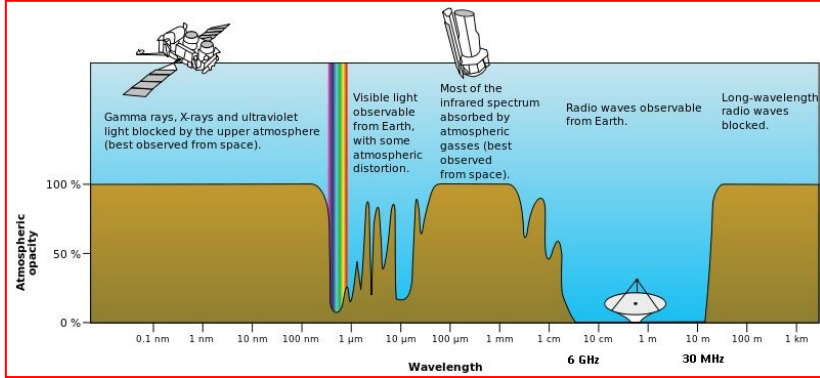

Normally, air allows propagation of essentially all radio-frequencies.⁹

Between 30 MHz and 6 GHz, there is very little absorption of waves by the atmosphere, making long-range transmission practical. A second consideration is that within the RF-MW range, natural sources are almost entirely absent.

The sun emits tiny amounts of MW radiation, and what little there is, is absorbed by the atmosphere. At telecommunications frequencies, natural levels are miniscule: $3 \mu\text{W}/\text{m}^2$.

The implication is that life has evolved entirely in absence of the radiations we use for broadcasting and telecommunications.

The electromagnetic fields known to the human body are the endogenous ones, from the heartbeat, from the nervous system and other cells. These signals are presently at least hundreds of times lower than common environmental levels.

⁹ Rain effects are generally undetectable until about 11 GHz, and even at 18-23 GHz (where many short-haul microwave systems operate) it is rarely a problem, except during severe rainstorms. Smoke particles are too small to have refractive effects, and smoke attenuation might only occur through the plume of a major fire.

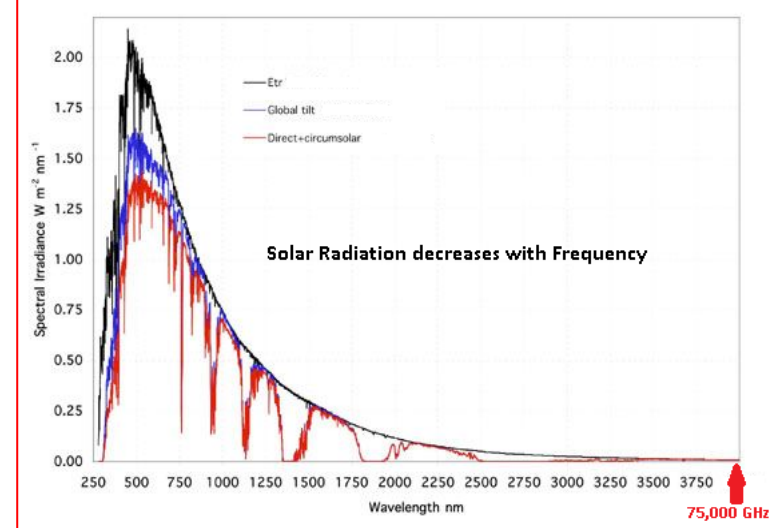

Use of broadcasting and microwave communications is increasing continuously with industrial expansion, and the industry deploys these applications under the assumption of zero short-term or chronic risks to human populations, with the exception of heating effects.

Many technical applications attempt to reserve segments of the spectrum for their specific purposes. National organizations such as the FCC in the US and the CRTC in Canada rent segments of the electromagnetic spectrum to specific purposes.¹⁰

Non-natural electric and magnetic fields thus propagate through space as electromagnetic waves, losing power density as they radiate. They are characterized by their frequency and modulation, and classified according to conventional domains, as shown below. Individual domains have specific names, but

¹⁰ In a majority of cases, international coordination is not important for interference purposes, but is relevant to standard setting or marketing purposes.

more general designations, **Radio Frequencies** (RF), and **Microwaves** (MW) are frequently used. **Infrared** extends from 1000 to 400,000 GHz, **Visible light** from 400,000 to 800,000 GHz, followed by Ultraviolet, X-rays and γ -rays. Over this range, they acquire a variety of personalities, and the interactions of these waves with inert material and living systems vary tremendously.

Conventional Names of Electromagnetic Domains		
Extremely Low Frequencies	ELF	3-300 Hz
Voice Frequency	VF	300-3000 Hz
Very Low Frequencies	VLF	3000-30,000 Hz
Low Frequencies	LF	30,000-300,000 Hz
Medium Frequencies	MF (RF)	300,000 Hz-3 MHz
High Frequencies	HF (RF)	3-30 MHz
Very High Frequencies	VHF (RF)	30-300 MHz
Ultra High Frequencies	UHF (MW)	300 MHz-3 GHz
Super High Frequencies	SHF (MW)	3-30 GHz
Extra High Frequencies	EHF (MW)	30-300 GHz

Band	RADAR-MICROWAVE		INDUSTRIAL-SCIENTIFIC-MEDICAL	
	GHz	λ , cm	MHz	λ , m
L	1.1-1.4	27.3-21.4	13.56	22.12
S	2.6-3.95	11.5-7.6	27.12	11.06
C	3.95-5.85	7.6-5.13	40.68	7.37
X	8.2-12.4	3.66-2.42	915 (ovens)	0.328
K _u	12.4-18	2.42-1.67	2,450 (ovens)	0.122
K	18-26	1.67-1.16	5,800	0.052
K _a	26-40	1.16-0.75	22,125	0.014

Frequency bands assigned to Radar systems and the Industrial-Scientific-Medical frequencies.

Electrical power is transmitted at a frequency of **50-60 Hz**. Many technical applications use the band between 100 kHz and 1 THz:

- navigation signals,
- **AM** radio (0.5 to 1.6 MHz),
- industrial heating,
- amateur short-wave radio / medical diathermy (~10 MHz),
- Citizens Band channel 9 is 27.065 MHz,
- **FM** (88 to 108 MHz),
- **TV** (VHF, 54 to 216 MHz; UHF, 470 to 890 MHz),
- microwave ovens (915 MHz, 2.45 GHz),
- satellite communications,
- weather radar/microwave relay stations (1 GHz-100 GHz).

3.2.2.1. Ionization Limit

An important limit in the electromagnetic spectrum is the ionization threshold. Few atoms have ionization energies lower than 5 eV. This energy corresponds to a wavelength of 0.16 μm , in the near ultraviolet (red mark). This limit has been used to claim that biological effects from radiation below that energy (non-ionizing) can only be attributed to thermal effects.

This view is incorrect because free electrons and protons exist transiently in living system, and the fields do influence enzymes, and other critical parts of living systems. This is confirmed by many observations. Even natural light is confirmed to have impacts. The lifespan of *Drosophila* is substantially reduced by exposure to intense non-ionizing light, and the same effect was observed in mice [Massie, 1993].

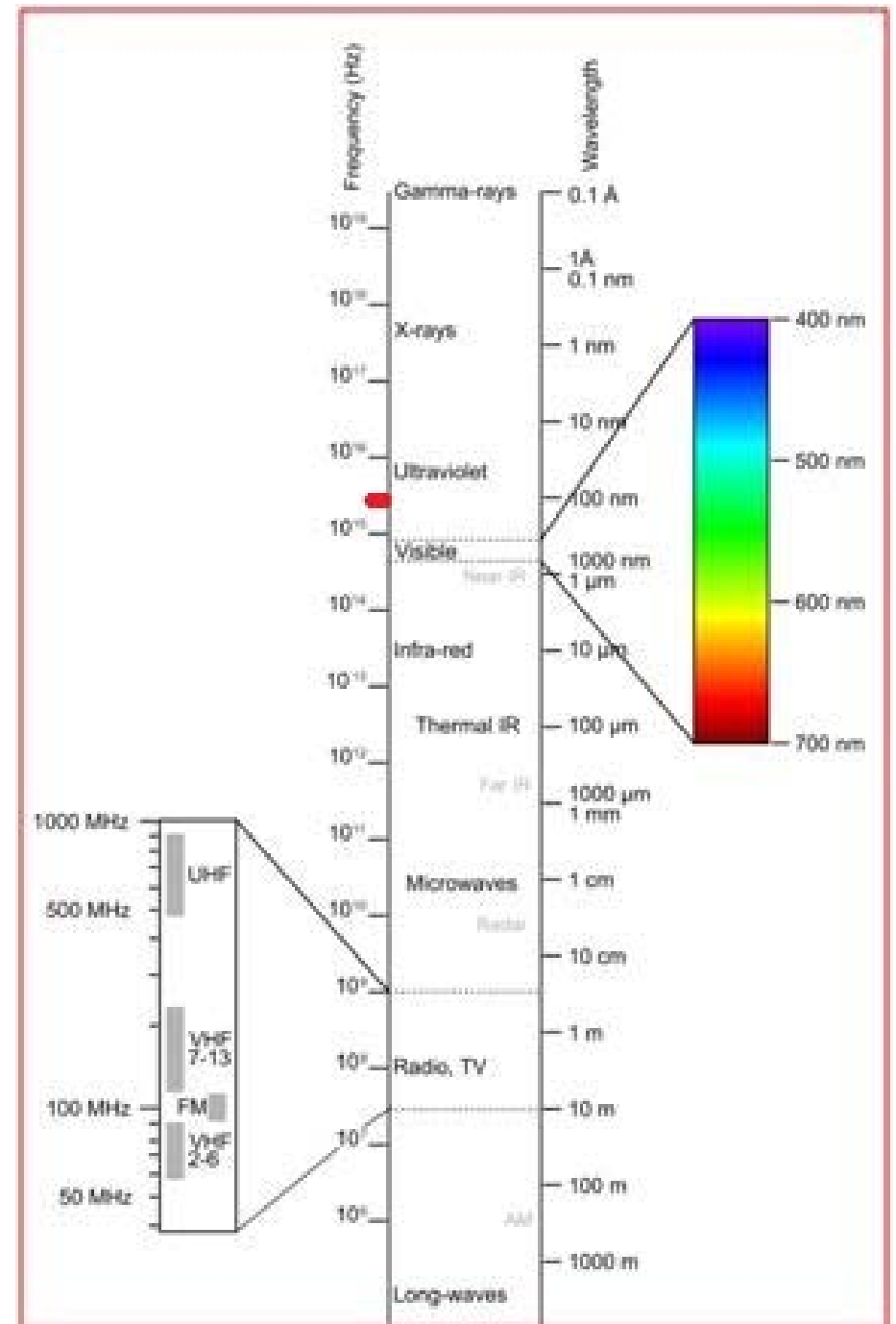

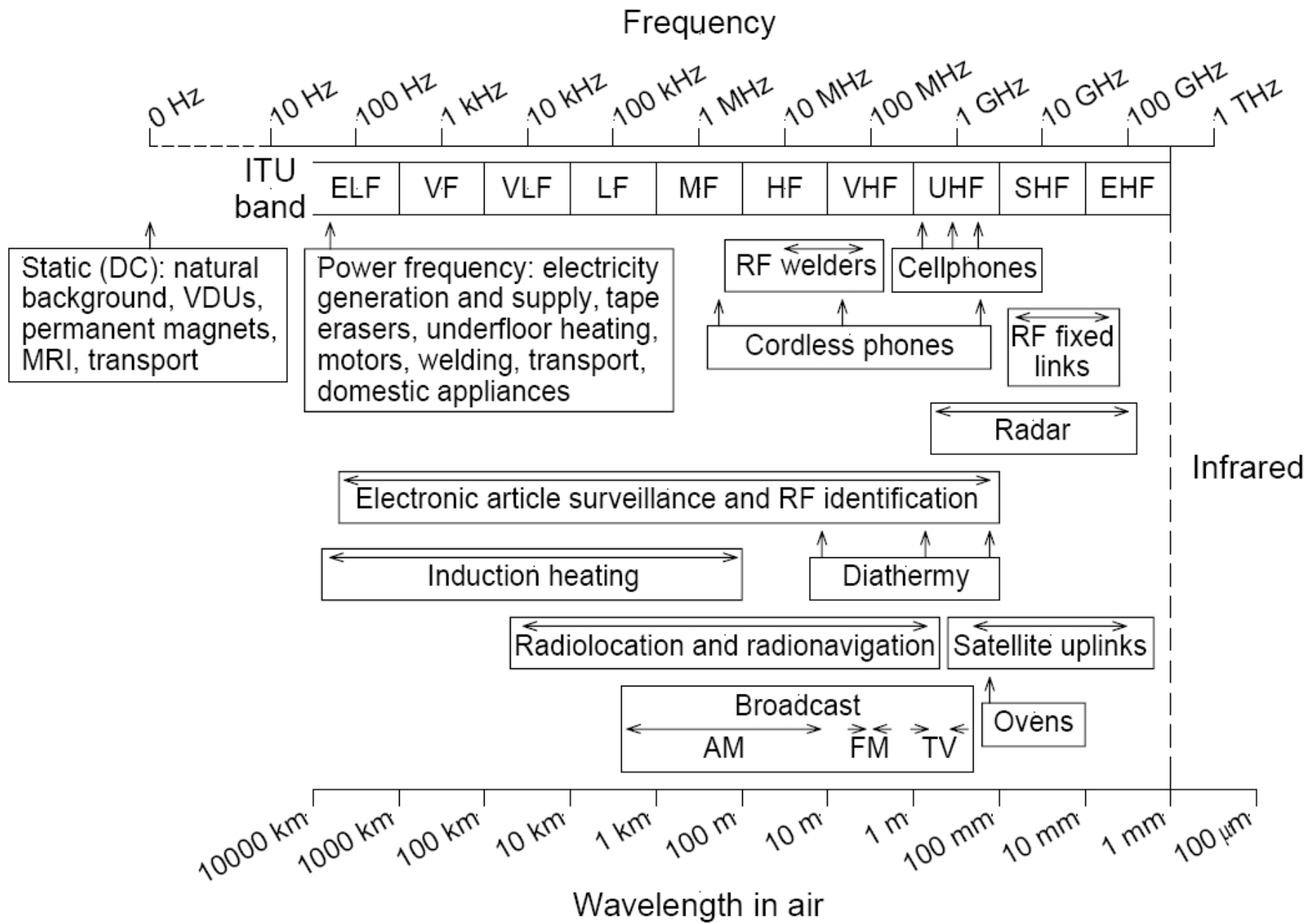

3.2.2.2. Modulation: AM, FM, PM

Radio stations need to broadcast audio signals. Very large antennas would be needed to broadcast low frequencies such as audio signals, since antennas must be comparable in size to the wavelength to be effective.

But if a high frequency, the *carrier*, is added to the voice signal, more reasonable antenna sizes are achievable.

Furthermore, since a different *carrier* frequency can be added to voice signals, multiple voice signals can easily be separated from one another at the receiving end by a simple electronic process called tuning (selection of the *carrier*) and signal demodulation (restoring the audio signal by filtering out the *carrier*).

Transmission of analog audio and video signals can be achieved by three basic methods:

- amplitude modulation (AM),
- frequency modulation (FM) and
- pulse modulation (PM).

In all modes, an electromagnetic wave of specific frequency, the carrier wave, is irradiated by an antenna.

In the AM system, the frequencies are in the MHz range, and the amplitude of the audio signal, with a bandwidth of ~20 kHz, is simply added to the carrier.

In the FM system, the frequencies are in the 100 MHz range, and the amplitude of the audio or video signal, with a bandwidth of 20 kHz or more, is used to change the carrier frequency around its central value.

In the PM system, the frequencies are usually in the GHz range, and the sine-wave is present or absent, or transiently increased, depending on digital data flow. Other complex,

advanced schemes of modulation are widely used. Phase modulation proceeds by skipping a time-segment of a regular sine-wave, producing slight discontinuities which are conserved as data.

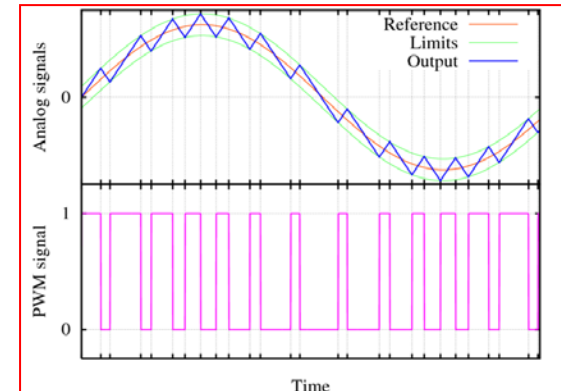
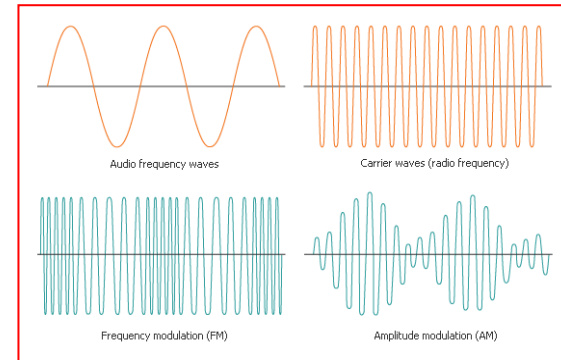

Methods of modulating a carrier wave with an audio signal.

- **Frequency Modulation** or FM changes the carrier frequency slightly according to the audio signal amplitude.
- **Amplitude Modulation** or AM changes the carrier amplitude according to audio signal amplitude.
- **Pulse Modulation** or PM is a form of AM where the carrier is present at full amplitude, attenuated (shown) or completely eliminated.

Modulation can become extremely complex, especially when many coding systems are used concurrently.¹¹ Suffice it to say that the signal coming from a digital telephone can change in intensity and frequency in an adaptive way about 1000 times per second. An incredible amount of automated work is going on to achieve effective cellular phone voice transmissions.

3.2.2.3. Pulsed Electromagnetic Fields

Pulsed Electromagnetic Fields (**PEMFs**) are transient, wideband electrical events (see oscillogram at right). PEMFs are phase-coordinated, frequency-rich packets of energy with potential for addressing many cellular living systems. They result from dielectric breakdowns produced accidentally by the electrical contacts of tools/appliances and power networks, by the switching of fast-acting semiconductors and are broadcast deliberately by communications devices to send data, or by therapeutic devices for tissue regeneration.

Exposure to the agent should be fairly common in industry, particularly in workers handling power tools, but an inventory of occupational settings with high concentrations of the agent has not been performed, although it is known that some groups of electrical utility workers are exposed [Deadman, 1988]. The prevalence of PEMFs is presently largely unknown, because until the advent of the IREQ-Positron dosimeter [H eroux, 1991c], there was no practical instrument available. The pulses originate at a point on an electrical circuit, and propagate for some distance along electrical wires, while progressively radiating their energy.

¹¹ In the case of modern digital systems, such as cellular telephones, the modulation methods have gone beyond frequency-shift keying and into time-domain multiple access techniques, using quadrature amplitude modulation.

Theoretical calculations [Schwann, 1983; Drago, 1984] indicate that higher frequencies would be more effective in affecting the cell nucleus. The literature on PEMF fields has shown an influence on many *in vitro* systems [Ohashi, 1982; Akamine, 1985; Takahashi, 1986; Mikolajczyk, 1991; Khalil, 1991], including human lymphocytes [Nordenson 1984; Nordenson 1988; Franceschi, 1991; Skyberg 1993], and high-frequency pulses are used for therapeutic growth stimulation

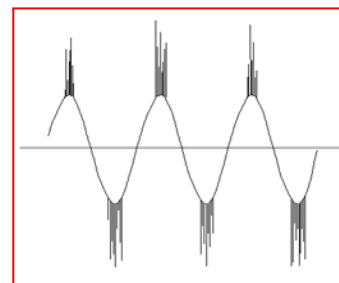

[Bassett, 1982]. Since pulsed fields appear to stimulate growth, some physiologists believe that the proliferative effect may be quite generalized.

Superposed on this 60-Hz waveform are transient discharges resulting from the dielectric breakdown of air in the small gaps of a motor rotor. The discharges occur at the maxima because this is when the field is highest.

Because knowledge in the complex area of biological effects of PEMFs is so limited, no standards exist for worker protection, although “electromagnetic pulses are under investigation for establishment of TLVs” (ACGIH). In spite of the absence of standards, in an out-of-court agreement reached in September 1990, Boeing has paid more than half a million dollars to a worker who claimed to have developed leukemia from exposure to electromagnetic pulse radiation while at his job (1983-85) developing missile components [Muhm, 1992]. Boeing will also provide a comprehensive medical program for 700 employees who have worked in similar occupations since the 1960s.

PEMFs have also been related to reproductive hazards [Delgado, 1982; Ubeda, 1983; Juutilainen, 1986; Martin, 1988; Berman, 1990; Zusman, 1990], and may act as a non-specific

stressor [Oroza, 1987]. PEMFs have also been identified as acting in magneto-suppression of melatonin production by the pineal gland [Lerchl 1991; Yaga 1993]. An epidemiological correlation was found between exposure to PEMFs and lung cancer [Armstrong, 1994].

Many laboratory studies indicate that the energy of a signal is only one of many factors determining its biological action. Modulation type has an influence, but the present standards of exposure do not take modulation of EMFs into account.

3.2.2.4. Electromagnetic Compatibility

The small wavelength of microwave radiation allows its transmission in relatively tightly **focused beams**, similar to a beam of light, using reflective parabolic antennas.

On the other hand, the long wavelengths of radio-frequencies are ideal for **broadcasting** [Rubenstein, 1988].

The electromagnetic spectrum is an extremely busy place. In the absence of assigned carrier frequencies (ie, 550 kHz, 92.5 MHz), all radio station audio signals would occupy the same bandwidth, and so would interfere with one another. This is similar to many people talking within a room, making it difficult to tell voices apart. But if people talk at very different pitches, as determined by their carrier frequency, it is easy to separate the signals.

A major discipline in electrical engineering aims to keep various utilizations of electromagnetic radiation from interfering with one another: the cell phone should not disturb the cardiac pacemaker or the medical infusion pump.

For this purpose, adjustments are needed in the design of analog and digital circuits for computers, home entertainment, medical, telecom, industrial process control, and automotive equipment, as well as military and aerospace systems.

It involves cabling, grounding, filtering, shielding, digital circuit grounding and layout, and electrostatic discharge control.

Critical aspects are switching power supplies and variable-speed motor drives, digital circuit power distribution and decoupling, PCB layout, RF and transient immunity and power line disturbances.

The concepts are applicable to analog and digital circuits operating from below audio frequencies to those in the GHz range [Ott, 2009].

3.3. Electrical Properties of Biological Materials

3.3.1. Characteristics of Tissues

3.3.1.1. Electrolyte Content

The electric properties of biological tissues are considerably affected by their water content, since water is the medium that allows ion movement. Of the total body water, 62% is in the intracellular space and about 38% in the extracellular space. Tissues with high water content (more than 90%) are blood, vitreous humor, lymphatic and cerebrospinal fluids. Moderate water content tissues (less than 80%) are skin, muscle, brain and internal organs. Low water content tissues (about 40%) are bone, fat and tendon. Inter-species differences are small, except for fatty tissue, since its water content can range from a few percent to more than 40%, depending on the animal.¹² An extensive table of the specific resistance of biological materials has been compiled by Geddes [1967].

¹² An interesting fact is that the water content of tumors is different from that of normal tissues. Tumor tissues have, on the average, 83% water content versus 75% for normal tissue. Their conductivity is 67% and their dielectric constant 25% higher than normal tissue.

3.3.1.2. Resistive Structures and Membranes

Beyond electrolytes which favor ionic species and charge transfer of both electrons and protons, the body contains relatively resistive tissues (bone) and membranes (fascia). The division of the body into large cavities, as well as the presence of strong dielectrics (air in lungs, stomach) influences the patterns of body currents at large scale. From work on electrical burns, it is expected that actual current circulation patterns within human anatomy are complex [H eroux, 1993]. The most conductive tissues are those likely to least concentrate electric potentials from any induced field.

3.3.1.3. Trans-Membrane Potentials

At a cellular level, polarization of biological membranes has important function, and its disruption would have important consequences. When exposed to oscillating electro-magnetic fields, such polarized membranes interact non-linearly (asymmetrically). A consequence of this is that amplitude-modulated broadcast waves can be demodulated by biological systems. The basic structure of an AM demodulator is a diode followed by a low-pass circuit: inexpensive crystal radio receivers use a small diode followed by a slowly-responding earphone to directly use AM broadcasts. By a similar mechanism, biological material could decode high-frequency electromagnetic radiation, thus merging the biological effect of the carrier wave with the effect of the modulating signal.

Loss of membrane polarization in living cells is intimately associated with cell death, except for the case of the momentary depolarization involved in neuron firing. Some measurements suggest that anesthesia by barbiturates is mediated by a loss of membrane potential in nerves [Iazzo, 1990] through enhancement of the conductivity of some membrane proteins.

Repeated artificial depolarization of cells in the *central nervous system* have been shown to result in mitosis [Cone, 1976].

Other research has shown that the application of ac electric fields to cartilaginous cells resulted in fluxes of Na^+ and Ca^{++} which triggered synthesis of DNA.

The membrane potential of cells can determine their developmental fate, possibly indicating the way to the process of regeneration, as mentioned in section 3.7.1.

Membrane potential controls how big the primary brain grows in frogs, and any bioelectric abnormalities could be connected with degenerative brain diseases [Pai, 2015].

However, the fields present in the common electromagnetic environment do not have enough intensity to challenge the powerful natural potentials used by biology for membrane polarization or to force charges across channels (below). In a special category are the purely magnetic effects operating by changes in the orientation of the spin of electrons or protons. If these charges are free, even momentarily, the energy required for the effect is vanishingly small.

3.4. Biological Mechanisms of Electromagnetism

Epidemiology, animal and cell experiments have confirmed the effects of EMR on biological systems and on human health (Chapter 4). Specifically, effects on cancer rates and ROS have been repeatedly confirmed. But here, our concern is with the basic mechanisms that explain such observations. Briefly, the points of action can be summarized as:

- Interference with short movements of electrons (generally <1.5 nm) and protons (generally <0.3 nm).
- Hyperpolarization of mitochondrial inner membrane, resulting in electron leakages (Reactive Oxygen Species) from Complexes I and III.
- Reduction in pH, with liberation of Calcium because of competitive binding with protein such as albumin.

3.4.1. The “kT” problem

An objection to the existence of impacts of weak extremely-low frequency (ELF) magnetic fields is labeled the “kT problem” [Binhi, 2007]. This “problem” can be summarized by the very large ratio between the energy available from a quantum of ELF radiation, (2.47×10^{-13} eV) and the thresholds for ionization of atoms (4.34 eV for potassium), chemical activation (~ 0.7 eV), or even the 0.156 eV able to transfer protons across gA channels [Chernyshev, 2002].

What these numbers show is that ELF magnetic fields cannot have effects through these particular mechanisms, but a detailed theoretical analysis [Binhi, 2007] does not preclude that ELF-magnetic field effects occur in other ways. Magnetic fields can alter the shape of the orbitals of particles without substantially altering their energies, possibly leading to very low thresholds for magnetic field biological effects. Free radicals are extremely susceptible to magnetic fields, because they involve free electrons. Rather than a pure energy problem, as stated above, the true “problem” is to identify the sensitive biological structures that can be disturbed by very low-amplitude ELF magnetic fields.

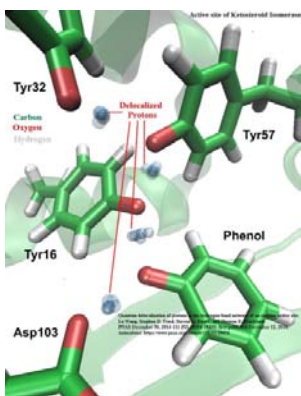

3.4.2. Delocalized charges: electrons and protons

Electrons and protons are regularly exchanged between molecules, very actively in mitochondria, but also in all cells of the body. Many of these exchanges occur through a process called *tunneling* in which charges are briefly released over small distances. So, to achieve biological action, EMFs do not have to breach any

specific energy barrier, but simply need to interact with ongoing low-energy electrical activity.

Even at a fundamental level, some protons in biological molecules are delocalized because of quantum mechanics, and in other molecules, such as benzene, electrons oscillate freely between metastable structures. So, in electrical conductors like copper, EMR displaces electrons, while in biological systems it acts on delocalized charges that influence reaction or transfer rates.

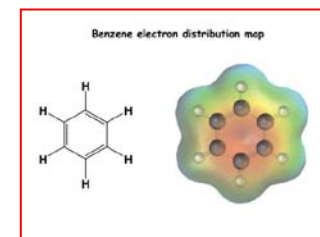

3.4.3. Enzymatic Reactions

Some enzymes operate faster than predicted by classical thermodynamics, and their increased speed can be explained by tunneling of protons or electrons through activation barriers [Garcia-Viloca, 2004; Olsson, 2004]. Quantum tunneling for protons over 6 nm through bridging by water molecules has been observed in tryptamine oxidation by aromatic amine dehydrogenase, for example, and tunneling in enzymatic reactions is now widely accepted in biological models [Masgrau, 2006].

It is of interest to examine how protons flow through the ATP Synthase *F_o water channels*. The protons trickle through a thin

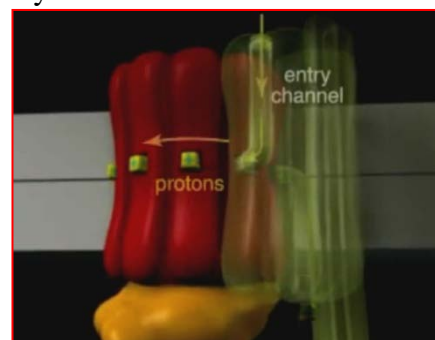

pipe of water molecules, propelled by a static electric field of about 180 kV/cm.

Protons move through water channels in ATP Synthase.

Adiabatic proton tunneling through ATPS should be more efficient than non-adiabatic

coupling, implying that EMR disturbances along the channel could result in loss of channel transparency. Both electrons and protons tunnel through the channel, making theoretical analysis complex, especially as electrons meet with different protons along a chain. Since protons are much heavier than electrons (x1836), their wavelength is 43 times shorter (inverse square root), and electrons tunnel over longer distances [Moser, 1992; Gray, 1996]. Thus, electron tunnelling is observed to span large fractions of nano-meters, while proton tunnelling occurs mostly within a hydrogen bond (less than 0.197 nm). The hydrogen bond strength (23.3 kJ/mol) is just 5 times the average thermal fluctuation energy. Quantum chemical calculations show that this strength can vary as much as 90%, depending on the level of cooperativity or anti-cooperativity within water molecule chains, which corresponds to a bond length change of 9%, or 0.018 nm [Hus, 2012]. This limited reach of proton tunneling and its delicate dependence on water cluster structure may be major factors underlying the sensitivity of ATPS performance to magnetic field exposure.

3.4.4. Interaction of Magnetic Fields with Water

Russian physicists have reported, through measurements of dielectric constant, and of optical changes in dilute rhodamine 6G water solutions [Semikhina 1981; Semikhina 1988], that very low levels of ELF magnetic fields (25 nT) can alter the structure of water, and that the effects of the altered water structure would be particularly important under high concentrations of protons and water molecules. An interesting aspect of these changes in water structure is that the complete transition between states of bulk water takes several hours. Such changes could be connected to the fact that water molecules can be of the *para* or *ortho* type, with lifetimes of the order of one hour, according to anti-parallel or parallel proton spins of the hydrogens [Tikhonov and Volkov, 2002].

This is important because adiabatic tunneling of protons is only allowed to the same spin state, and so water spin composition could affect water proton transparency. The transitions between *para* and *ortho* forms are forbidden by quantum mechanics. They rarely occur during random thermodynamic fluctuations, as a proton drifts away from its OH radical, releases Pauli Exclusion Principle constraints, and allows spin flipping according to an external magnetic field. The *ortho* state is sensitive to the magnetic field. This dependence of the transitions on thermodynamic instability is convenient to explain the slow rate of saturation of magnetic fields on water. These special effects are not overwhelmed by thermodynamics, and facilitate hydrogen transfer in specific reactions that involve compact active site structure where sites are closer than 0.27 nm together and if the transfers becomes quantum coherent [Offord 2019; Hu 2019].

3.4.5. DNA Conductance

Electron transfer along a DNA strand may happen using molecular π -orbitals of base pairs [Henderson, 1999]. Methyltransferase, normally involved in DNA repair, can interrupt electron transfer by inserting an insulating chemical group into the π -stack. Thymidine dimer mutations can be fixed by electron transfer [Rajski, 1999]. These electrical properties of DNA have inspired the notion that EMF could act on the fractal structure of DNA directly [Blank, 2009; Blank, 2011].

3.4.6. A Variety of Mechanisms

The brain (see it at www.BrainFacts.org/3D-Brain), the immune system, the heart and some components of blood (rouleaux formation) seem to have the capability of reacting to EMR quickly, even with uniform body exposures, possibly related to their use of oxygen.

Electromagnetism can interact with living systems through a variety of known mechanisms, but some mechanisms undoubtedly remain to be discovered. A brief explanation would state that EM magnetic fields interact:

- ✚ at low intensities by alterations in the movement of free protons (H^+) and electrons that in turn change cellular metabolic rate (at levels of 20 nT) and other enzymatic reactions,
- ✚ at medium intensities through the charging of membranes, and effects on cryptochromes and magnetite (detection of Earth's 50 μT magnetic field by numerous animals),
- ✚ at high intensities through heat ($\sim 500 \mu T$).

Whether electric or magnetic fields are involved is dependent on the physiological system, and on the frequency of the radiation. In any case, there are a wide variety of reported EM influences on biological systems at very low exposures. Avoidance of the undesirable environmental effects of such fields would require adapted engineering in present power and telecommunications technology, but industry has turned a blind eye to the evidence, preferring to deny the science that supports all but the thermal effects. This avoidance is characterized as the *Procrustean Approach* [Maisch, 2009].

3.4.7. Magnetic Sensors

To unravel the basic mechanisms of EMR action, it is always useful to glance at what is available in the marketplace. Modern electronics provides interesting examples, such as the MOSFET, where tiny signals can control large energies: a voltage applied to a gate with nominally zero current allows control of substantial drain currents. Biological systems have their own sources of energy, and the magnetic field need only contribute a perturbing influence. In

the context of ELF magnetic field effects, it is useful to examine the transducers of magnetic field-measuring instruments.

Induction coils have long been the item of choice for many such instruments, but they suffer from a lack of analogy with possible biological equivalents, in that they gather signal from substantial surfaces (the coil core), and then concentrate the action of the magnetic flux variations gathered over that considerable area at a single point, the contact of the winding. Hall-effect probes are closer to the mark, in that they detect the potential difference created by a magnetic field on a current flowing in a semi-conductor. Here, the magnetic field acts to deflect a current flow that is powered by an extraneous source. This device dissociates the energy available from the magnetic field itself from the energy it controls.

Another electronic device even closer to the biological transducer we seek is the Spin Tunnel Junction (Micromagnetics, 2012). Such a junction is made of two ferromagnetic metal layers separated by an insulating barrier of a few nanometers. If a small voltage is applied across the junction, electrons will tunnel through the barrier, according to the ambient magnetic field.

The device's magnetic field sensitivity is based on spin-coherent tunneling: the probability of an electron tunneling across the barrier is dependent on its spin, because an electron of a given spin must tunnel to an unfilled state of the same spin. Even the simplest free-electron descriptions of Spin Polarization and Tunneling MagnetoResistance confirm that junction characteristics are determined not only by the ferromagnetic layers, but depend as well on the properties of the barrier [Tsymbal, 2003]. Solid-state Spin Tunnel Junctions can detect magnetic fields as low as 0.26 nT at 60-Hz. What these semiconductor devices demonstrate is that very small magnetic fields can have effects within the bulk of

materials, and that changes in the properties of insulating materials such as the water channel of ATP Synthase can affect electron tunneling.

3.4.8. Electronic Spin

Electrons normally whirl around their atomic nuclei in even numbers and in set orbits, with pairs of electrons with spins in

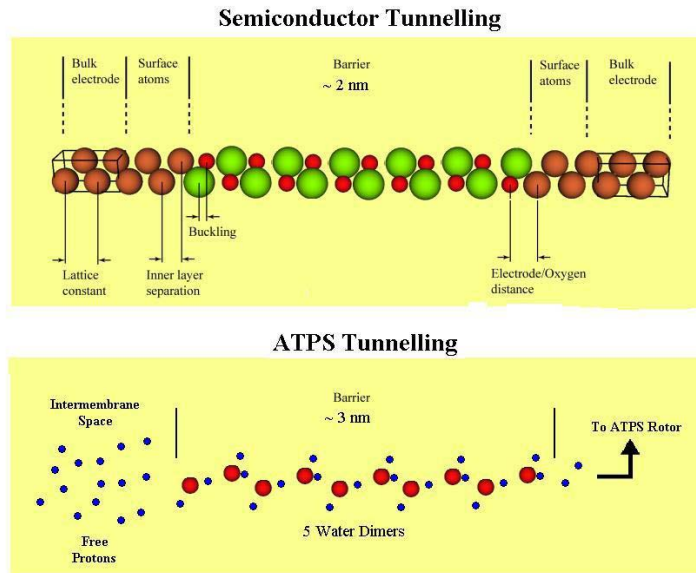

There are similarities as well as differences between semi-conductor tunneling and ATPS tunneling. Both involve oxygen (small red spheres); tunneling distances (above), as well as the voltages applied are similar. But in semiconductor tunneling (top of figure), only electrons are mobile, while protons also move within ATPS. In the semiconductor, spin is determined by ferromagnetic electrodes, while in ATPS (bottom of figure), spin is determined by interaction with water molecules (red sphere with two small blue protons). The transparency of the channel is determined in both cases by the external magnetic field. Sensitivity is 0.26 nT for the semiconductor, and about 20 nT for ATPS. Green spheres are magnesium.

opposite directions. Light can disrupt this routine by causing electrons to jump to different regions within the same molecule or to neighboring molecules, resulting in pairs of molecules with unpaired electrons. In this transient state, the unpaired electrons can spin in the same direction (parallel), or in opposite directions (antiparallel), and the amount of time they spend in each state can be influenced by magnetic fields. Some chemical reactions only occur when unpaired electron spins are parallel, and others only when they are antiparallel. Magnetic fields can influence the outcome or speed of chemical reactions involving radical pairs by causing flips between the two spin states, and by controlling the relative amount of time the molecular players spend in each.

The molecular basis for this magnetic sensing has been demonstrated in *Drosophila melanogaster*, but only in the presence UV-A/blue light, <420 nm [Gegear, 2008]. Geomagnetic fields are perceived by chemical reactions involving a specialized photoreceptor, the UV-A/blue light photoreceptor *cryptochrome*. Cryptochrome has been identified in the retinal tissue of several migratory birds and of other animals, including humans. Pigeons appear to use both celestial rotation and magnetic cues for navigation, with possible species-specific differences [Walcott 1988; Benvenuti 1988; Wiltschko 1991].

In birds' eyes, the cryptochromes may mediate this light-dependent magnetic sensing [Zapka 2009]. Signals from the free radicals may then move to nerve cells in "cluster N", ultimately telling the birds where north is. Earth's field lines act as magnetic "signposts", positional information created by combinations of field inclination (angle) and intensity at specific geographic locations.

High-frequency radio waves, known to disrupt the spin behavior of radical pairs *in vitro*, stopped robins from navigating [Ritz, 2004]. A cryptochrome isolated from the garden warbler produces long-lived radical pairs [Liedvogel, 2007]. One of the four known bird cryptochromes is found in all ultraviolet/violet cone cells in the retinas of both European robins and chickens, specifically in the stacked membrane discs of the photosensitive outer segment of the cone cell, which also contains the visual pigments [Wiltschko, 2011].

Genetic deletion and replacement experiments showed that the cryptochrome is an essential feature of the light-dependent magnetic sensing system in *Drosophila*.

Many mammalian tissues [Kirschvink, 1992], including the brain of man, contain minute amounts, 4 ppb, of magnetite.¹³ Although we now know that magnetite is uniformly dispersed in the human brain, its function and importance are unknown.

3.4.9. Window Effects

In bio-electromagnetics, it is frequently observed that biological end-points do not follow a simple dose-effect response with respect to field intensity or frequency [Postow, 1986]. Because many effects have been shown to have a threshold field, and then a higher field at which the effect disappears, the term “window effect” has been used.

These observations run somewhat contrary to strong traditions in toxicology and hygiene. However, activation at low levels coupled to inhibition at high levels is a common pathway interaction in gene expression. As well, it could be a reflection

¹³ Magnetite was previously known to exist in living pigeons, fish and magnetotactic bacteria (Appendix 2).

of a physiological system being perturbed at low levels and inhibited at a higher level.

This suggests that the some effects of EMR might be physiologically based, as opposed to non-specific aggression (such as free radicals).

This occurrence of electromagnetic fields effects over narrow ranges of frequency and field strength does not simplify the task of investigators. It makes the reproduction of observations more difficult. Furthermore, the actual electromagnetic environment of humans is invariably more complex than what is provided in laboratory settings.

For example, the electrical power network radiates harmonics and transients (high frequency perturbations) even more effectively than the 60-Hz power it is designed to distribute. When one adds the further influence of duty factors, repetition rates and field combinations (heterodyne effect) to the experimental picture, the design of environmentally-relevant experimental protocols even within the restricted ELF bandwidth appears overwhelming.

It should be kept in mind that a dose-response found in an epidemiological survey may not actually correspond to a dose-response at a physiological level. The actual epidemiological observation of a dose-response may simply correspond to a larger volume of space (therefore, higher probability of effect) within which bioactive exposure conditions (intra-window) can be found. Electrically hypersensitive people are impacted heavily not only by intensity but also by the duration of exposures.

Window effects have been observed both in ELF [Wei, 1990 and a large number of others] and in the RF-MW frequency range [Sheppard, 1979; Blackman, 1977, 1980, 1989; Chang,

1982; Dutta, 1982, 1990; Postow, 1981] and with pulses [Rein, 1985; Rubin, 1989; Cadossi, 1991].¹⁴

The existence of window effects implies that conditions for magnetic field effects can be destroyed in the tissue by field overdose. This would tend to confirm the idea that EMF effects act by affecting normal, but labile physiological mechanisms (for example, the interaction of an enzyme with a substrate). Some window effects of this type have been documented in the hepatic P-450 enzymes.

3.4.10. Field Coherence

An electromagnetic field is said to be *coherent* if it behaves like a simple harmonic oscillator (for example, the undisturbed rhythmicity in the pendulum of a clock). An *incoherent* field can have such rhythmicity, but only for short periods of time, because it is disturbed in its regularity by an external (random) phenomenon. At any point in time, it is not possible to predict the phase or amplitude of an incoherent source, whereas it is easy to predict the phase or amplitude of a coherent oscillator. Therefore, an incoherent field has a very short coherence time as compared to a coherent field which has, in principle, an infinite coherence time.

Enhancement of ornithine decarboxylase (an enzyme intimately associated with the proliferation of normal and tumor cells) activity following exposure of L929 cells to an ELF field of 10 μ T was found to depend on the coherence time of the applied field. When the coherence time was made less

¹⁴ Windows are found elsewhere in biology. For example, a carcinogenic effect of ionizing radiation can occur in a group of cells with a normal dose dependence yielding cell transformation, followed by a gradual decrease of effect at high doses, because the cells are lethally injured by the radiation [Upton, 1961].

than 1 second by disturbing the 60-Hz oscillator (by rapidly shifting between 55 and 65 Hz), no enhancement of the enzyme activity was detected. Only coherence times greater than 10 seconds showed enhancement of activity [Litovitz, 1991, 1993].

A similar enhancement of ornithine decarboxylase could be caused by 915 MHz microwaves modulated at 60 Hz, but the effect could be abolished if the modulating field was made incoherent in the manner described above.

This work supports the notion that coherence of fields is important in determining biological activity and that electromagnetic signals certainly cannot be weighed simply in terms of their energy (heat) content; more subtle aspects of the field must be taken into account.

These theoretical considerations have major impact on **public policy dealing with telecommunications**, for example, where industry (which uses complex signals, due to its data content) may be submitted to regulations based on results evolved in laboratories which mostly use simple *coherent* signals.

3.5. Appendix 1: Classical Electrophysiology

3.5.1. Polarization of Biological Membranes

Proteinoid microspheres, synthetic cells assembled from thermal proteins (synthetic copolyamino acids), glycerol and synthetic lecithin are used as simple synthetic systems for studying biological membranes. Spontaneous oscillatory and action potentials, as well as the tendency to form junctions are observed [Ishima, 1981]. In totally synthetic models, individual cell polarizations are as high as 20 mV. These facts indicate that electrical polarization is a basic property of synthetic and biological membranes and that, most likely, the whole of the evolution of life has proceeded in its presence.

It is well known that the cytoplasm and the extracellular fluid do not contain the same concentration of important ions, such as Na⁺ and K⁺. These differences in concentration lead naturally to a membrane potential [McLaughlin, 1989]. The potential produced by differences in concentration between the two sides of a membrane can be calculated using the Nernst equation:

$$E = RT \frac{\ln \left[\frac{C_{ext}}{C_{int}} \right]}{ZF}$$

where E is the potential, R the gas constant, T temperature, C the ionic concentrations, Z the valence of the ion, and F Faraday's constant. Therefore, the maintenance of homeostasis in the cell is tied to the membrane potential.

The inside of mammalian cells is negative with respect to the outside by about 80 mV. When one considers the number of cells in the human body, it can be calculated that each one of us is kept alive by an integrated potential of approximately 6,000 millions of kV.

The application of a potential of 80 mV to a structure as thin as a cell membrane implies an electric field in the neighborhood of 100 kV/cm, or about 4 times the value that leads to flashover in air. Mitochondrial membranes are even more highly stressed at 150-200 mV (as much as 30 MV/m across 7 nm).

3.6. Appendix 2: Bio-Electricity

Bio-Electricity consists essentially of natural uses of electricity, as opposed to Electro-Biology which is concerned with the consequences of application of electricity to living systems.

3.6.1. Bioelectric fields in Development

The application of dc potentials to tissues can have a profound impact on their development. It has been known for a long time

that embryos generate electrical currents which are driving some aspects of fetal development. A distortion of these electric fields can result in malformation [Hotary, 1992]. In 1972, Smith obtained the first successful stimulation of the regeneration of a complex extremity by artificial means in a mammal, obtained by electrical stimulation [Smith, 1967, 1974]. The concept of this experiment is illustrated below.

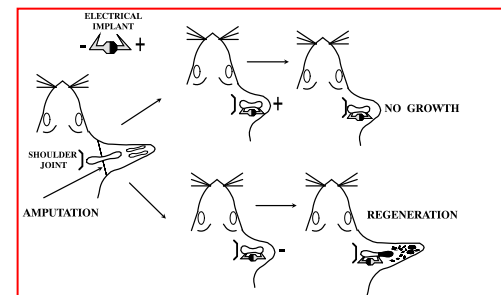

Implanting a small electrical device in the amputation stump of the rat foreleg results in a major amount of limb regeneration if the device is oriented so that the end of the stump is made negative, similar to the salamander current of injury. When the device is reversed, there is no regeneration.

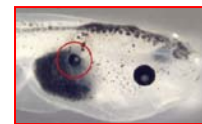

Cells can be instructed in their development by purely electrical means. By altering the membrane potential of intestinal cells of tadpoles (*Xenopus laevis*) by 20 mV, researchers were able to grow eyes in this (red circle), and other locations in the tadpole body [Pai, 2012].

Regenerative signals can extend further than local stimulation [Busse, 2018].

3.6.2. Bioelectric fields in the Brain

Collective neuron oscillations in the brain allows a coherence field to be established between neurons [Wutz, Ezzyat,

Lundqvist, Bastos, 2018; Haller, 2017]. Alterations of these oscillations have been involved in disorders such as autism, Parkinson's, depression, anxiety and aging.

3.6.3. Magnetic Sensing

Many animals use the Earth's magnetic field for orientation and navigation. There are three entirely different mechanisms of action used by living systems.

1. microscopic *magnets* within the structure of organisms,
2. free-radical chemistry, based on *electronic spin*,
3. a transducer based on magnetite in birds [Winklhofer, 2012].

3.6.3.1. Magnets for Positioning

Some bacteria use strings of particles mechanically interacting with the earth's field. *Magnetobacterium bavaricum* with tooth-shaped magnetite crystals (each 100 nm long), in chains.

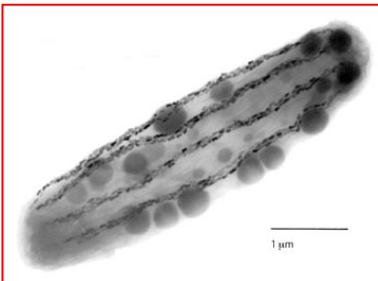

A consistent magnetic polarity, allow swimming along magnetic field lines. Bees use magnetic fields for navigation [Schiff, 1991].



The blind mole rat, which lives underground, navigates by combining dead reckoning with a sense of the Earth's magnetic field [Kimchi, 2001].

Types of brain waves

Fast gamma waves have been linked to states of high attention. 30 to 80 Hz



Beta waves may be involved in movement and complex tasks such as memory and decision making. 12 to 30 Hz



The first neuronal oscillations discovered, alpha waves appear when a relaxed person closes his eyes. 8 to 12 Hz



Theta oscillations may help the brain sort information essential for navigation. 4 to 8 Hz



Slow delta waves mark deep sleep and anesthesia. 1.5 to 4 Hz



3.6.3.2. Spin, Cytochrome and Magnetite

The cryptochrome molecule, when exposed to blue light, forms a pair of two radicals (molecules with a single unpaired electron) with the spins of the two unpaired electrons correlated. The surrounding magnetic field affects this correlation (parallel or anti-parallel), and this in turn affects the length of time cryptochrome stays in its activated state. This cryptochrome activation would allow birds to "see" the magnetic field [Rodgers 2009]. Cryptochromes are therefore thought to be essential for the light-dependent ability of the fruit fly *Drosophila melanogaster* to sense magnetic fields [Gegear, 2008].

Another similar cryptochrome mechanism dependant on ultraviolet light has also been found in the monarch butterfly [Guerra, 2014].

The magnetic compass of robins [Engels, 2014] is disrupted by a wide range of environmental electromagnetic fields up to 5 MHz, but is restored when shielded.

A second magnetoreception model relies on Fe_3O_4 , a natural oxide with strong magnetism. The Earth's magnetic field leads to a transducible signal via a physical effect on this magnetically sensitive oxide [Cadiou, 2009].

Micrometer sized intracellular structure of iron-rich crystals, most likely single-domain magnetite, detected in trout, are capable of rapidly detecting small changes in the external magnetic field. Such sensors could explain interference of ac power-line magnetic fields with magnetoreception, as reported in cattle [Eder, 2012].

UK scientists discovered nanoparticles of an artificial form of magnetite in brain tissue of 37 people living in the UK and Mexico. The particles differ from naturally occurring magnetite

found in human and animals brains. It seems that magnetite nanoparticles in the atmosphere can enter the human brain through the olfactory system, where they might pose a risk to human health [Maher, 2016].

3.6.3.3. Human Magnetic Sensing

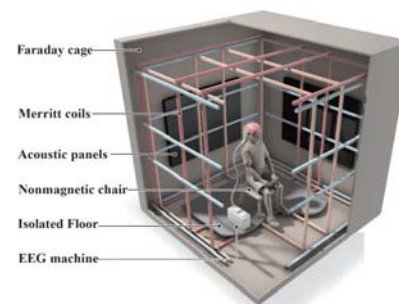

The human perception of static magnetic field has been shown to produce a drop in amplitude of EEG alpha oscillations (8-13 Hz) from horizontal rotation of Earth-strength magnetic fields when the static vertical magnetic field was

directed downwards [Wang, 2019].

3.6.4. Electric Sensing

The shark and platypus locate their prey by detecting the pulsed electromyographic signals emitted by muscle (hiding is ineffective if the victim makes electrical noise by moving). The regular attacks of sharks on trans-oceanic telephone cables had long been a mystery. Apparently, the EM signals they carry induce sharks to attack (cable shielding is therefore indicated). Sharks have a specialized organ allowing the detection of



electric currents in the range of fA,

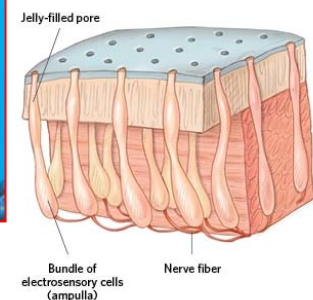

or 6000 ions/second [Kalmijn 1992; Johnson 1983]. When a shark is ready to bite, it closes its eyes, and relies entirely on its electrical sense for prey localization (if this ever happens to you, please remember that you read it here first).

Sharks and other cartilaginous fish have ampullae of Lorenzini to detect electric fields in water for prey localization. The small pits (not the bubbles) in this silky shark's snout read electromagnetic signals. (*Ntl Geographic, Feb 2002*).

Dolphins can detect 4.6 microvolts per centimeter [Czech-Damal, 2014] using vibrissal crypts on their snout. Actually, all



primitive animals with backbones could sense electricity. Many mammals, reptiles, fish and birds lost the sense over time. The detection mechanism is thought to be based on electromagnetic induction ($d\Phi/dt$).

To keep predators away, a device, the *Electronic Shark Defense System*, has become popular in Hawaii. Users strap

devices, the size of an oversized watch or wallet to their ankles, wetsuits or surfboards, sending electric pulses through the water.

3.7. Appendix 3: Electro-Therapy

It has been confirmed over the last decade that electromagnetic fields are capable of **beneficial** effects such as the **stimulation of repair**, specifically in **bone**, and perhaps of the **regeneration of body tissues in general** [Becker, 1985]. This evidence has provided support for the notion of **bio-activity** of electric and magnetic fields among academics, and much interest has been directed towards the development of **electro-therapeutic methods**. The FDA has approved EMF generators to treat bone fractures that have stopped healing,

and to fuse spinal vertebrae in people with intractable back pain.

3.7.1. Bone Fracture and other Repairs

The magnetic permeability of biological materials is so close to that of free space (to one part in a million) that lower frequency *magnetic fields* traverse living tissues *unperturbed*. This property is an incredible opportunity, yielding a practical method of acting inside the body with a uniformity that cannot be approached by any therapeutic (chemical) agent.

In spite of its weak ability to induce significant currents at normal environmental intensities below the MW frequency range, the magnetic field is therefore of practical value in providing good penetration into living tissues when applied as high intensity transients. It is used as a means of driving therapeutic osteogenesis (Appendix 3).

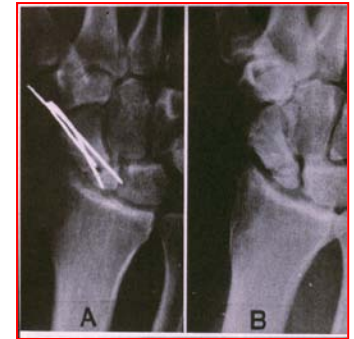

Since the beginning of the 19th century, several investigators have reported success in treating pseudo-arthroses and non-union with electrical stimulation [Boyer, 1816; Geddes, 1984]. Interest was revived starting in the 1950s, as a result of the demonstration of the piezoelectric properties of bone [Brighton, 1977, 1977a; Bassett, 1982, 1982a]. Initially, dc currents were used, which were soon replaced by pulsed electric, and then magnetic fields.

Pulse repetition rates of 60 to 75 Hz are thought optimal. Two magnetic coils placed about the limb induce field intensities of 0.2 to 2 V/m within the bone tissue (ie ~ 2 to 20 mA/m²). In 1982, the Journal of the AMA labeled the method of

electromagnetic stimulation “a major improvement in traumatic orthopedic surgery”. Studies have shown that the pulses induce a number of significant biological effects [Chang, 2004].

The induction of cell potentials may be found to be a sustaining force for many tissues. Cartilage is said to benefit from exercise because the mechanical compression it creates pushes fluids through microscopic holes. This fluid movement generates so-called “streaming potentials” [El-Messierey, 1992], which apparently have a role in maintaining cartilage structure.

These potentials are generated during high impact aerobics or more violent exercise, explaining the beneficial effect of such activities on bone density [Liang, 2005].

Electromagnetic stimulation facilitates ligament healing in rabbits [Frank, 1983] and could perhaps promote the regeneration of peripheral nerves and the spinal cord following injury.

Pulsed fields increase a joint’s production of natural anti-inflammatory agents, such as transforming growth factor β , and companies are developing applicators for arthritis sufferers [Aaron, 1999].

Binding of calcium to calmodulin is enhanced by PEMF [Pilla, 1999], production of insulin-like growth factor II is increased in bone [Ryaby, 1998], and some genes are controlled by PEMFs.

3.7.2. Electroconvulsive Therapy



Although the treatment is somewhat controversial, primarily because it lacks the *elegance* of simple drug administration, electroconvulsive

therapy, **ECT** is the treatment of choice for severely depressed patients who are suicidal, or who fail to respond to

antidepressant drugs. Currents of up to 5 A, temple to temple, are administered for a few seconds. The technique may also be of use in relieving Parkinson’s disease. A side effect is memory loss. There is no good explanation for its effectiveness.

Kindler *Transcranial Magnetic Stimulation* (TMS, section 5.6.11.6) may soon replace ECT [Grunhaua, 2000] for depression and for the control of epilepsy [Berenyi, 2012]. It has the ability to focus stimulation, avoiding the seat of memory, the hippocampus. Until recently, pulses of magnetic fields focused on the brain were not powerful enough to elicit more than the perception of flashes of light (magnetophosphenes). But in the Tesla range, a magnetically stimulated region of the brain becomes temporarily unresponsive after stimulation (in *shock*). Both stimulation and inhibition can be used in studies.

3.7.3. Electropuncture and Electroporation

The motion of ions in solution under the influence of electric fields is limited by cell membranes. Therefore, as a result of the resulting charge concentration accumulating on the membranes, a difference of potential is produced [Weaver, 1990]. If the applied voltage exceeds even for a very brief time a value of approximately 1 V, the membrane punctures. This puncture is reversible, under most circumstances. Red blood cells, for example, can be resealed [Kinosita, 1977] by simple incubation after having been loaded with medication (a practical application allowing chronic drug delivery).

A softer electric solicitation will simply increase (reversibly) the porosity of the membrane, and molecules of selected molecular weight, for example therapeutic genes, can be introduced into cells (*electroporation*).

3.7.4. Deep Brain Stimulation



In Deep-Brain Stimulation, electrodes are implanted into targeted brain regions deliver electrical stimulation to either excite or inhibit activity in a neural circuit of interest. Battery-powered implanted pulse generators deliver electrical stimulation from 20 to 200 times per second. DBS is currently

approved in the U.S. or Europe for the treatment of essential tremor, Parkinson’s disease, dystonia (a motor disorder that causes extreme twisting and repetitive motions), epilepsy, and obsessive-compulsive disorder. The therapy is currently in clinical trials for depression [Rao, 2018], Alzheimer’s disease [Pohodich, 2018], addiction, and more. More than 100,000 patients worldwide have received DBS [Hamani, 2012], mostly to treat Parkinson’s disease.

3.7.5. Treatment of Cancer

Magnetic fields at high intensities have been used successfully to treat mammary tumors in the rat. Nordenström, a professor of diagnostic radiology at the Karolinska Institute in Stockholm, has gathered data to support the existence of an electrochemical biological system of closed circuit transport among tissues involving selective channels. Physiological events would result in tissue polarizations which induce structural and functional modifications [Nordenström, 1985]. Healing is one such event. Using this principle, he has obtained regression (such results have been obtained in many

other laboratories) and even complete healing of metastatic cancers in the lung. From other sources, it is indeed known that cancer of the cervix, for example, can be detected by purely electrical means [Langman, 1947].

3.8. Appendix 4: Special Relativity and Magnetic Fields

Although the demonstration that follows is not strictly valid, it does show the principle involved in the production of magnetic forces from Coulomb forces “perverted” by the *motion* of electric charges. Special Relativity states that objects moving in a given direction appear compressed in a frame of reference at rest by a factor (for proof of the equation, see

http://www.exploratorium.edu/relativity/time_math.html)

$$\frac{1}{\sqrt{1 - \frac{v^2}{c^2}}}$$

where v is the speed of motion and c is the speed of light. The faster the movement, the more compression there is. If we imagine an experiment in which a positive test charge is some distance away from an electric wire carrying current, the situation is as follows.

The positive ions in the wire are at rest with respect to the test charges at the bottom, and these exert a given repulsive force on the test charges. The electrons carrying the current are however moving; according to special relativity, the distances between them are decreased by the factor given above. Therefore, their apparent density is correspondingly increased by the same factor. The test charge therefore sees a net negative charge on the wire and experiences a force towards it.

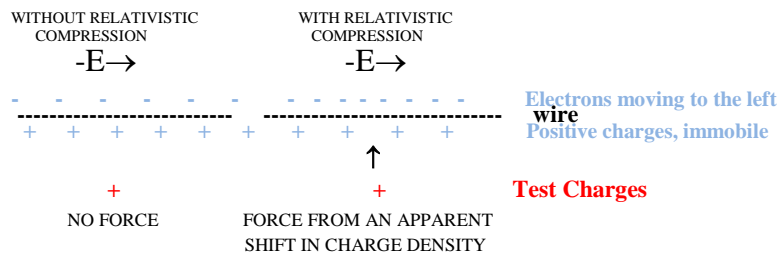

Note that this force is at right angles to the electric field which is inducing the electrons to move along the wire.

In conclusion, the motion of charges induces forces which are at right angles to their movement. Such a force is in fact attributed to the “magnetic field”. Since it is the motion of charges which causes the compression of distances to obtain an apparent imbalance in charge density, charge motion and therefore *electric current is a pre-requisite* to the existence of magnetic forces.

From the previous thoughts, one can understand that the strength of the magnetic field in fact depends directly on the value of the speed of light, as the amount of distance compression, according to Special Relativity, also depends on it. If the speed of light was infinite, there would be no magnetic field. If the speed of light was comparable to the speeds attained by electrons in wires, the magnetic force would be extremely strong...

3.9. Appendix 5: Dielectric Relaxation

When biological materials are submitted to a step function (rapid rise) electric field, they require a certain time to react and polarize, in a process called *relaxation*. The finite velocity

of ions traveling and rotating through water and the action of membranes slowing the ions’ progress indicate that the medium cannot respond instantaneously to the applied field. In fact, at extremely high frequencies, it becomes less and less possible for the material to do so, and this is why dielectric constants generally fall in value with frequency. This frequency-dependent behavior gives rise to changes in dielectric constant with frequency, also called *dispersion* by physicists.

Since the *relaxation* of biological materials involves ion movements, and since energy inputs into a system tend to degrade to heat, it should be no surprise that the phenomenon of electrical relaxation involves some energy loss. In all body tissues, as the dielectric constant falls with frequency, the dielectric loss increases.

The dielectric constant and the energy loss incurred in the process of polarization are combined in the concept of the complex dielectric constant of biological materials, which consists of *a real and an imaginary part*.

The designation is exactly analogous to the classical nomenclature used in electrical impedance, where reactance (capacitive or inductive) is said to be *imaginary* with respect to resistance, because it contributes an out-of-phase current (by 90°) which does not involve power loss. For the dielectric constant, which manifests as capacitance *from the start* and is therefore imaginary itself, the statement that it includes an imaginary part means that the dielectric constant includes a “dispersive” property that *does* contribute to energy loss. The imaginary part of an already imaginary variable is real: therefore, the imaginary part of the dielectric constant is a real energy loss !

This dielectric loss adds to the classical ohmic (resistive) loss. This is the mechanism of heating by microwaves.

If one were to measure the dielectric constant of living tissues over frequency, one would obtain results similar to those in the figure below. The values are much higher than that of water because of the presence of insulating membranes and macromolecules. Further, the dielectric constant shows irregularities in its decay with frequency, and those irregularities are named the α , β and γ dispersions.

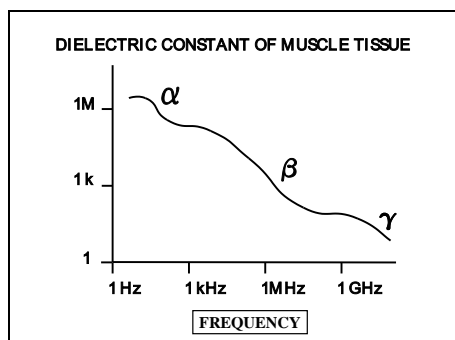

The *alpha dispersion* is thought to result from the presence of cell membranes (including also the Golgi apparatus, endoplasmic reticulum and nuclear membrane).

The *beta dispersion* results from equilibration at the boundaries of membranes. Specific periods are required before the boundaries can reach neutrality, giving rise to the relaxation phenomenon.

The *gamma dispersion* is related to the rotational properties of polar molecules in water. It is characterized by a single relaxation frequency slightly lower than that of pure water, because of the presence of macromolecules.

As the dielectric constant goes down with frequency, the conductivity of biological materials increases because a higher

frequency diminishes the influence of any polarization or bond, and all ions can “participate” in conduction.

It should be clear that relaxation phenomena contribute considerable complexity to the electrical properties of biological materials. Detailed analysis of these problems can be found elsewhere [Pethig, 1979].

3.10. Summary

Electric and magnetic fields apply forces to electrical charges on dissolved ions and larger biological molecules, influencing their motion or position. Bound charges can be polarized by fields to a degree measured in terms of the dielectric constant. Electrical energy can be transmitted across space by electrostatic induction (capacitive coupling) or electromagnetic induction. Maxwell's equations govern electromagnetism and explain the transmission of electromagnetic energy as waves traveling through free space. The electromagnetic spectrum is a diverse and rich territory, filled with important technical applications. EM fields can be amplitude, frequency or pulse modulated. Biological materials have special enzymatic structures and free charges throughout the body which interact with EM fields.

Magnetic fields at very low levels alter the structure of water in such a way that the performances of biological enzymes are affected. Window effects and field coherence have been surprising observations in the laboratory. Bioelectromagnetics is rich with elements of electro-physiology, bio-electricity and electro-therapy.

3.11. Bibliography

Aaron 1999 RK, Ciombor DM et al. Power frequency fields promote cell differentiation coincident with an increase in transforming growth factor- β 1 expression. *Bioelectromagnetics* 20(August):453.

Akamine 1985 T, Muramatsu H, Hamada H, Sakou T. Effects of pulsed electromagnetic field on growth and differentiation of embryonal carcinoma cells. *J Cell Physiol* 124(2):247-254.

- Armstrong 1994** B, Thériault G, Guénel P, Deadman J, Goldberg M, Héroux P. The association between exposure to pulsed electro-magnetic fields and cancer in electrical utility company workers from Québec and France. *American Journal of Epidemiology*, Vol. 140, No. 9, pp 805-820.
- Bastos 2018** A et al. Laminar recordings in frontal cortex suggest distinct layers for maintenance and control of working memory. *Proceedings of the National Academy of Sciences*. Vol. 115, January 30, 2018, p. 1117. doi: 10.1073/pnas.1710323115.
- Bassett 1982** CAL, Valdes MG, Hernandez E. Modification Of Fracture Repair With Selected Pulsing Electromagnetic Fields. *J Bone Joint Surg (Am)* 64(6):888-895
- Bassett 1982a** CAL, Mitchell SN, Gaston SR. Pulsing Electromagnetic Field Treatment In Ununited Fractures And Failed Arthrodeses. *JAMA* 247(5):623-628
- Becker 1985** RO, Selden G. *The Body Electric*. William Morrow & Co, New York.
- Benvenuti 1988** S, Ioale P. Initial Orientation Of Homing Pigeons: Different Sensitivity To Altered Magnetic Fields In Birds Of Different Countries. *Experientia* 44(4):358-359
- Berényi et al 2012** Closed-Loop Control of Epilepsy by Transcranial Electrical Stimulation. *Science*, Vol 337, 10 August 2012.
- Berman 1990** E. The developmental effects of pulsed magnetic fields on animal embryos. Special Section: NICHD Workshop on the Reproductive Effects of VideoDisplay Terminal Use, 4 November, National Institutes of Health, Bethesda, MD.
- Binhi 2007** VN, Rubin AB. Magnetobiology: The kT paradox and possible solutions. *Electromagnetic Biology and Medicine*; 26: 45-62.
- Blackman 1977** CF, Elder JA, Weil CM, Benane SG, Eichinger UC. Two Parameters Affecting Radiation-Induced Calcium Efflux From Brain Tissue (meeting abstract). International Symposium on the Biological Effects of Electromagnetic Waves, 1977. 30 October - 4 November 1977, Airlie, VA.
- Blackman 1980** CF, Benane SG, Elder JA, House DE, Lampe JA, Faulk JM. Induction Of Calcium-Ion Efflux From Brain Tissue By Radiofrequency Radiation: Effect Of Sample Number And Modulation Frequency On The Power Density Window. *Bioelectromagnetics* 1(1):35-43
- Blackman 1989** CF, Kinney LS, House DE, Joines WT. Multiple Power-Density Windows And Their Possible Origin. *Bioelectromagnetics* 10(2):115-128
- Blank 2009** M and Goodman R. EMFs stress living cells. *Pathophysiology* 16 pp. 71-78.
- Blank 2011** M and Goodman R. DNA is a fractal antenna in electromagnetic fields. *Int. J. Radiat. Biol.* Vol 87, no 4, pp 409-415.
- Boyer 1816** A. *A Treatise on Surgical Diseases and the Operations Suited to Them*. (Translation by Stevens AH), New York, T and J Sword, 395 pp.
- Brighton 1977** CT, FriedenberG ZB, Mitchell EI, Booth RE. Treatment Of Nonunion With Constant Direct Current. *Clin Orthop* (124):106-123
- Brighton, 1977a** CT. Editorial Comment: Bioelectrical Effects On Bone And Cartilage. *Clin Orthop* (124):2-4
- Busse 2018** SM et al., "Cross-limb communication during *Xenopus* hindlimb regenerative response: Non-local bioelectric injury signals," *Development*, 145:164210, 2018.
- Cadiou 2010** H and McNaughton PA. Avian magnetite-based magnetoreception: a physiologist's perspective" *Journal of the Royal Society Interface (The Royal Society)* 7 (Suppl 2): S193–205. doi:10.1098/rsif.2009.0423.focus
- Cadossi 1991** R. Lymphocytes And Pulsed Electromagnetic Fields. *J Bioelectr* 10(1&2):205-212
- Chang 2004** K. Pulsed Electromagnetic Field Stimulation of Bone Marrow Cells Derived from Ovariectomized Rats affects Osteoclast Formation and Local Factor Production. *Bioelectromagnetics* 25:134–141.
- Chernyshev 2002** A, Cukierman S. Thermodynamic view of activation energies of proton transfer in various gramicidin channels. *Biophysical Journal* 2002;82:182-192.
- Coltman 1988** JW. *The Transformer*. Scientific American.
- Cone 1976** C, Cone C. Induction of mitosis in mature neurons in central nervous system by sustained depolarization. *Science*, 9 April 1976, p. 155-158.
- Czech-Damal 2011** NU et al. Electroreception in the Guiana dolphin (*Sotalia guianensis*). *Proceedings of the Royal Society B*. Published online July 27, 2011. doi: 10.1098/rspb.2011.1127.
- Deadman 1988** JE, Camus M, Armstrong BG, Héroux P, Cyr D, Plante M, Thériault G. Occupational and Residential 60-Hz Electromagnetic Fields and High-Frequency Electric Transient: exposure assessment using a new dosimeter. *Am Ind Hyg Assoc J* 49(8):409-419.
- Delgado 1982** JMR, Leal J, Monteagudo JL, Gracia MG. Embryological changes induced by weak extremely low frequency electromagnetic fields. *Journal of Anatomy* 134: 533-51.
- Dietrich 1992** F, Feero WE, Dietrich F, Robertson D, Steiner G. Safety Of High Speed Magnetic Levitation Transportation Systems: Final Report On Magnetic Field Testing Of The TR07 Maglev System. Report No. DOT/FRA/ORD-92/09.I, Report No. DOT/FRA/ORD-92/09.II
- Drago 1984** GP, Marchesi M, Ridella S. The Frequency Dependence Of An Analytical Model Of An Electrically Stimulated Biological Structure. *Bioelectromagnetics* 5(1):47-62
- Dutta 1990** SK, Das K, Blackman CF. Further Studies On Intensity Dependence Of The Induction Of Acetylcholine Esterase Activity By Modulated Radiofrequency Radiation (meeting abstract). *Bioelectromagnetics Society, 12th Annual Meeting*, 10-14 June, San Antonio, TX, p. 93
- Dutta 1992** SK, Das K, Ghosh B, Blackman CF. Dose Dependence Of Acetylcholinesterase Activity In Neuroblastoma Cells Exposed To Modulated Radio-Frequency Electromagnetic Radiation. *Bioelectromagnetics* 13(4):317-322
- Eder 2012** Magnetic characterization of isolated candidate vertebrate magnetoreceptor cells. www.pnas.org/cgi/doi/10.1073/pnas.1205653109
- El-Messierly 1992** MA. Magnetic Field Interaction With Streaming Potentials In Cancellous Bone. *Biomaterials* 13(3):168-171
- Engels 2014** S et al. Anthropogenic electromagnetic noise disrupts magnetic compass orientation in a migratory bird. *Nature*. Published May 7, 2014. doi:10.1038/nature13290.
- Ezzyat 2018** A et al. Closed-loop stimulation of temporal cortex rescues functional networks and improves memory. *Nature Communications*. Published online February 6, 2018. doi: 10.1038/s41467-017-02753-0.
- Franceschi 1991** C, Cossarizza A, Monti D, Salvioli S, Nuzzo C, Capri M, Scarfi MR, Bersani F. 50 Hz A.C. Electric Fields Affect Human Lymphocyte Proliferation Without Inducing Genotoxic Effects (meeting abstract). Annual Review of Research on Biological Effects of 50 and 60 Hz Electric and Magnetic Fields, 3-7 November 1991, Milwaukee, WI, U.S. Dept. of Energy, p. A-4
- Frank 1983** C, Schachar N, Dittrich D, Shrive N, de Haas W, Edwards G. Electromagnetic Stimulation Of Ligament Healing In Rabbits. *Clin Orthop* 175:263-272
- Frölich 1968** H. *Int. J. Quant. Chem.* 2:641.
- Garcia-Viloca 2004** M, Gao J, Karplus M, Truhlar DG. How enzymes work: analysis by modern rate theory and computer simulations. *Science* 2004;303 (5655):186-95.
- Geddes 1967** LA, Baker LE. The specific resistance of biological material-a compendium of data for the biomedical engineer and physiologist. *Medical and Biological Eng.* 5, 271-293.
- Geddes 1984** LA. The Beginnings of Electromedicine. *IEEE Engineering in Medicine and Biology Magazine*, December, pp. 8-23
- Gegear 2008** RJ et al. Cryptochrome mediates light-dependent magnetosensitivity in *Drosophila*. *Nature*. August 21; 454(7207): 1014–1018. doi:10.1038/nature07183.

- Glasgow 1981** AR, Carstensen EL. The shock record for 500 and 750 kV transmission lines in North America. *IEEE Transactions on Power Apparatus and Systems*, vol PAS-100, no 2, p. 559, February.
- Gray 1996** HB, Winkler JR. Electron transfer in proteins. *Annu. Rev. Biochem.* 65 :537-61.
- Grunhaua 2000** L et al. Repetitive transcranial magnetic stimulation is as effective as electroconvulsive therapy in the treatment of nondelusional major depressive disorder: An open study. *Biological Psychiatry* 47:314.
- Guerra 2014** PA, Gegear RJ & Reppert SM, A magnetic compass aids monarch butterfly migration. *Nature Communications* 2014 DOI: 10.1038/ncomms516
- Guy 1982** W, Chou CK. Hazard analysis: VLF through MF range, USAF School of Aerospace Medicine, Brooks Air Force Base.
- Haller 2017** M et al. Persistent neuronal activity in human prefrontal cortex links perception and action. *Nature Human Behavior*. December 18, 2017. doi: 10.1038/s41562-017-0267-2.
- Hamani 2012** C, J.N. Nobrega, "Preclinical studies modeling deep brain stimulation for depression," *Biol Psychiatry*, 72:916-23, 2012.
- Hart 1993** FX, Cole WH. The dielectric properties of apples in the range 0.1 to 100 kHz. To be published in *Journal of Materials Science*.
- Haupt 1984** RC, Nolfi JR. The Effects Of High Voltage Transmission Lines On The Health Of Adjacent Resident Populations. *Am J Public Health* 74(1):76-78.
- Henderson 1999** PT, Schuster GB. Long-distance charge transport in duplex DNA: The phonon-assisted polaron-like hopping mechanism. *Proceedings of the National Academy of Sciences* 96(July 20):8353.
- Hendrickson 1986** RC. Space Charge Drift From A +/- 400-kV Direct Current Transmission Line. *Bioelectromagnetics* 7(4):369-379
- Héroux 1991** P, Brissette Y, Dumas J, Bourdages M, Huang F. Assessment of Trauma in Tissues From Electrical Impedance Measurements, in *Electromagnetics in Medicine and Biology*, Brighton and Pollack, Eds., pp 215-221, San Francisco Press.
- Héroux 1991b** P, Bourdages M, Dumas J, Huang F, Evans, D. Electric Impedance Spectroscopy separates Thermal from Dielectric Damage in Electrical Burns, *Transactions of the Bioelectrical Repair and Growth Society*, Vol. 11, p. 46, Scottsdale, Arizona.
- Héroux 1991c** P. A dosimeter for assessment of exposures to ELF fields. *Bioelectromagnetics* 12(4):241-257.
- Héroux 1992** P, M. Bourdages. Monitoring living tissues by Electrical Impedance Spectroscopy. Accepted in *Annals of Biomedical Engineering*.
- Héroux 1993** P. Studies on the Pathophysiology of Electrical Burns and the Assessment of tissue Vitality and Viability by means of Electrical Impedance, Report 165-D-286A, Canadian Electrical Association Research & Development Dept., One Westmount Square, Suite 500, Montréal, Québec, H3Z 2P9.
- Héroux 1993b** P, Bourdages M. Electrical Measurement of Edema, in *Electricity and Magnetism in Biology and Medicine*, First World Congress for Electricity and Magnetism in Biology and Medicine, Martin Blank, Editor, San Francisco Press, p. 819-821.
- Hotary 1992** K. B.; Robinson, K. R. Evidence Of A Role For Endogenous Electrical Fields In Chick Embryo Development. *Development* 114(4):985-996.
- Hu 2019** S. et al., "Biophysical characterization of a disabled double mutant of soybean lipoxygenase: The 'undoing' of precise substrate positioning relative to metal cofactor and an identified dynamical network," *J Am Chem Soc*, 141:1555-67, 2019.
- Huš 2012** M, Urbic T. Strength of hydrogen bonds of water depends on local environment, *J. Chem. Phys.* 2012;136 (2012) 14, 144305-311.
- Iazzo 1990** PA, Olsen RA, Seewald MJ, Powis G, Stier A, Van Dyke RA. *Cell Calcium* 11 (8), 515-24.
- Ishima 1981** Y, Przybylski T, Fox SW. Electrical membrane phenomena in spherules from proteinoid and lecithin. *BioSystems*, 13 243-251.
- Jason 1971** AC, Lees A. Estimation of fish freshness by dielectric measurement. British Department of Trade and Industry, Torry Research Station report T71/7.
- Johnson 1983** CS, Scronce BL, McManus MW. Detection Of Dc Electric Dipole Fields By Nurse Sharks (*Ginglymostoma Cirratum*) (meeting abstract). *Bioelectromagnetics Society*, 5th Annual Meeting, 12-17 June, Boulder, CO, p. 112
- Juutilainen 1986** J, Harri M, Saali K, Lahtinen T. Effect of 100-Hz magnetic fields with various waveforms on the development of chick embryos. *Radiation & Environmental Biophysics* 25:65-74.
- Kalmijn 1982** AJ. Sharks, Skates, and Rays Detect Nanovolt per Centimeter Fields. Annual Review of Research on Biological Effects of Electric and Magnetic Fields from the Generation, Delivery and Use of Electricity Meeting, 8-12 November, San Diego, CA, U.S. Dept. of Energy, p. A-37.
- Khalil 1991** AM, Qassem W. Cytogenetic effects of pulsing electromagnetic field on human lymphocytes in vitro: chromosome aberrations, sister-chromatid exchanges and cell kinetics. *Mutat Res* 247(1):141-146.
- Kimchi 2001** T, Terkel J. Magnetic compass orientation in the blind mole rat *Spalax ehrenbergi*. *Journal of Experimental Biology* 204 (February):751-758.
- Kinosita 1977** K, Tsong TY. Formation And Resealing Of Pores Of Controlled Sizes In Human Erythrocyte Membrane. *Nature* 268(5619):438-441
- Kirschvink 1992** JL, Kobayashi-Kirschvink A, Woodford BJ. Magnetite Biomineralization In The Human Brain. *Proc Natl Acad Sci U S A* 89(16):7683-7687
- Langman 1947** L, Burr HS. Electrometric studies in women with malignancy of cervix uteri. *Science* 105:209-210.
- Lerchl 1991** A, Honaka KO, Reiter RJ. Pineal Gland 'Magnetosensitivity' To Static Magnetic Fields Is A Consequence Of Induced Electric Currents (Eddy Currents). *J Pineal Res* 10(3):109-116
- Pai1 2015** VP, J M Lemire, JF Paré, G Lin, Y Chen, and Michael Levin. Endogenous Gradients of Resting Potential Instructively Pattern Embryonic Neural Tissue via Notch Signaling and Regulation of Proliferation. *The Journal of Neuroscience*, 11 March 2015, 35(10): 4366-4385; doi: <http://dx.doi.org/10.1523/JNEUROSCI.1877-14>.
- Liang 2005 MTC et al.** Effects of six-month high-frequency impact-loaded aerobic versus strength training on bone health in premenopausal women. *Experimental Biology* 2005. April 3. San Diego. Abstract available at <http://www.eb2005-online.com/pdfs/004790.PDF>.
- Litovitz 1991** T, Krause D, Mullins JM. Effect of coherence time of the applied magnetic field on ornithine decarboxylase activity. *Biochem Biophys Res Commun* 178:862-865.
- Litovitz 1993** T, Krause D, Penafiel M, Elson EC, Mullins JM. The role of coherence time in the effect of microwaves on ornithine decarboxylase activity. *Bioelectromagnetics* 14:395-403
- Lundqvist 2018** M et al. Gamma and beta bursts during working memory readout suggest roles in its volitional control. *Nature Communications*. Published online January 26, 2018. doi: 10.1038/s41467-017-02791-8.
- Maisch 2009** DR. The procrustean approach: setting exposure standards for telecommunications frequency electromagnetic radiation, Doctor of Philosophy thesis, Science, Technology and Society Program - Faculty of Arts, University of Wollongong. <http://ro.uow.edu.au/theses/3148>.
- Martin 1988** AH. Magnetic fields and time dependant effects on development. *Bioelectromagnetics* 9:393-96.
- Masgrau 2006** L, Roujeinikova A, Johannissen LO, Hothi P, Basran J, Ranaghan KE, et al. Atomic description of an enzyme reaction dominated by proton tunneling. *Science* 312 (5771): 237-41.

- Massie 1993** H, Aiello V. Reducing exposure to visible light increases the life span of mice. American Aging Association, 23rd Annual Meeting, October, Abstract 71, p. 21.
- McLaughlin 1989** S. The Electrostatic Properties Of Membranes. *Annu Rev Biophys Biophys Chem* 18:113-136.
- Mikolajczyk 1991** H, Kamedula M. Ponderable Indices In The Offspring And Nucleic Acids Quantity In Endocrine Glands Of Rats Exposed To Real And Sham VDU Screens. *Pol J Occup Med* 4(1):85-92
- Moser 1992** CC, Keske JK, Warncke K, Farid RS, Dutton PL. Nature of biological electron transfer. *Nature*. 355(6363):796-802.
- Muhm 1992** JM. Mortality investigation of workers in an electromagnetic pulse test program. *Journal of Occupational Medicine*, vol 34, number 3, p. 287-292
- Nordenson 1984** I, Mild HK, Nordström S et al. Clastogenic effects in human lymphocytes of power frequency electric fields: in vivo and in vitro studies. *Radiat Environ Biophys* 23:191-201
- Nordenson 1988** I, Hansson Mild K, Ostman U, Ljungberg H. Chromosomal Effects In Lymphocytes Of 400 kV-Substation Workers. *Radiat Environ Biophys* 27(1):39-47
- Nordenstrom 1985** BEW. Biokinetic Impacts On Structure And Imaging Of The Lung: The Concept Of Biologically Closed Electric Circuits. *AJR Am J Roentgenol* 145(3):447-467.
- Offord 2019** C. Quantum Biology May Help Solve Some of Life's Greatest Mysteries. <https://www.the-scientist.com/features/quantum-biology-may-help-solve-some-of-lifes-greatest-mysteries-65873>
- Ohashi 1982** T, Inoue S, Sasaki H, Ashihara T. The side effects to the internal organs of pulsing electromagnetic fields (meeting abstract). *Bioelectrical Repair and Growth Society*, Second Annual Meeting, 20-22 September 1982, Oxford, UK, p.17.
- Olsson 2004** MH, Siegbahn PE, Warshel A. Simulations of the large kinetic isotope effect and the temperature dependence of the hydrogen atom transfer in lipoxxygenase. *Journal of the American Chemical Society* 126 (9): 2820=2828.
- Oroza 1987** MA, Calcicedo L, Sanchez-Franco F, Rivas L. Hormonal, Hematological And Serum Chemistry Effects Of Weak Pulsed Electromagnetic Fields On Rats. *J Bioelectr* 6(2):139-151
- Ott 2009** HW. *Electromagnetic Compatibility Engineering*. ISBN: 978-0-470-18930-6, Wiley, 2009.
- Pai 2012** VP et al. Transmembrane voltage potential controls embryonic eye patterning in *Xenopus laevis*. *Development*, Vol. 139, January 15, 2012. doi:10.1242/dev.073759
- Pethig 1979** R. Dielectric and electronic properties of biological materials, John Wiley and Sons.
- Pilla 1999** AA and al. EMF signals and ion/ligand binding kinetics: Prediction of bioeffective waveform parameters. *Bioelectrochemistry and Bioenergetics* 48(February):27.
- Pohodich 2018** et al.. Forniceal deep brain stimulation induces gene expression and splicing changes that promote neurogenesis and plasticity. *eLife* 2018;7:e34031. DOI: <https://doi.org/10.7554/eLife.34031>
- Postow 1981** E. Non-Linear Biological Responses To Complex Modulations. *Aeromedical Review* 3-81:236-245
- Postow 1986** E, Swicord ML. Modulated Fields And "Window" Effects, *Handbook of Biological Effects of Electromagnetic Fields*, Polk, C.; Postow, E., eds. Boca Raton, FL: CRC Press, Inc.; 425-460
- Rajski 1999** SR, Barton JK. Protein-modulated DNA electron transfer. *Journal of the American Chemical Society* 121(June 16):5615.
- Raloff 1987** J. Tumor promoters halt cell-cell 'talk'. *Science News*, vol 131, April 11th.
- Rao 2018** V, Sellers K, Wallace D et al. Direct electrical stimulation of lateral orbitofrontal cortex acutely improves mood in individuals with symptoms of depression. *Curr. Biol.* doi:10.1016/j.cub.2018.10.026 (2018); [www.cell.com/currentbiology/fulltext/S0960-9822\(18\)31355-1](http://www.cell.com/currentbiology/fulltext/S0960-9822(18)31355-1) www.eurekalert.org/pub_releases/2018-11/cp-ent112118.php
- Reece 2009** SY, Nocera DG. Proton-coupled electron transfer in biology: results from synergistic studies in natural and model systems. *Annual Review of Biochemistry* 2009;78: 673-699).
- Rein 1985** G, Pilla, A. Cell Adhesion: A New Model System For Studying The Effects Of Induced Current Waveform Parameters (meeting abstract). *Bioelectromagnetics Society*, 7th Annual Meeting, 16-20 June, San Francisco, CA, J-20
- Ritz 2004** T. Resonance effects indicate a radical pair mechanism for avian magnetic compass. *Nature*. 429:177-80.
- Rodgers 2009** CT and Hore PJ. Chemical magnetoreception in birds: the radical pair mechanism. *Proceedings of the National Academy of Sciences of the United States of America* 106 (2): 353–60. Bibcode:2009PNAS..106..353R. doi:10.1073/pnas.0711968106. PMC 2626707. PMID 19129499.
- Rubenstein 1988** E. Imaging with photons. *Scientific American Medicine*, CTM-III, p.2
- Rubin 1989** CT, McLeod KJ, Lanyon LE. Prevention Of Osteoporosis By Pulsed Electromagnetic Fields. *J Bone Joint Surg (Am)* 71(3):411-417
- Ryaby 1998** JT. Clinical effects of electromagnetic and electric fields on fracture healing. *Clinical Orthopaedics* 355(October):S205.
- Schiff 1991** H. Modulation of Spike Frequencies by Varying the Ambient Magnetic Field and Magnetite Candidates in Bees (*Apis Mellifera*). *Comp Biochem Physiol A* 100(4):975-985
- Schwan 1966** HP. Alternating current electrode polarization. *Biophysik* 3, 181-201.
- Schwan 1983** HP. Biophysics Of The Interaction Of Electromagnetic Energy With Cells And Membranes. *Biological Effects and Dosimetry of Nonionizing Radiation*. M. Grandolfo, S. M. Michaelson, A. Rindi, eds., New York: Plenum Press, p. 213-231
- Semikhina 1981** LP, Kiselev VF. Effect of weak magnetic fields on the properties of water and ice. *Russ. Phys. J.* 31:5351-5354.
- Semikhina 1988** LP, Kiselev VE, Levshin, LV, Saletskii, AM. Effect of weak magnetic fields on the luminescence-spectral properties of a dye in an aqueous solution. *J. Appl. Spectros.* 48:556-559.
- Sheppard 1979** AR, Bawin SM, Adey WR. Models Of Long-Range Order In Cerebral Macromolecules: Effects Of Sub-ELF And Of Modulated VHF And UHF Fields. *Radio Sci* 14(6S):141-145
- Skyberg 1993** K, Hansteen IL, Vistnes AI. Chromosome aberrations in lymphocytes of high-voltage laboratory cable splicers exposed to electromagnetic fields, *Scan J Work Environ Health* 19:29-34
- Smith 1967** SD. Induction Of Partial Limb Regeneration In *Rana Pipiens* By Galvanic Stimulation. *Anat. Rec.*, 158, 89-98.
- Smith 1974** SD. Effects Of Electrode Placement On Stimulation Of Adult Frog Limb Regeneration. *Ann. N. Y. Acad. Sci.* vol 238, 500-507.
- Takahashi 1986** K, Kaneko I, Date M, Fukada E. Effect of pulsing electromagnetic fields on DNA synthesis in mammalian cells in culture. *Experientia* 42(2):185-186.
- Tenforde 1983** T S, Geyer AB, Fujita TY, Bristol KS, Goulding FS, Budinger TF. Magnetic Field Monitoring With A Portable Dosimeter (meeting abstract). *Bioelectromagnetics Society*, 5th Annual Meeting, 12-17 June, Boulder, CO, p. 36
- Tikhonov 2002** VI, Volkov, AA. Separation of water into its ortho and para isomers. *Science* 296:2363.
- Trosko 1980** JE, Dawson B, Yotti LP, Chang CC. Saccharin may act as a tumour promoter by inhibiting metabolic cooperation between cells. *Nature*, 285:109

Trosko 1982 JE, Chang CC, Netzloff M. The role of inhibited cell-cell communication in teratogenesis. *Teratogenesis, Carcinogenesis and Mutagenesis* 2:31-45.

Trosko 1983 JE, Chang CC, Medcalf A. Mechanism of tumor promotion: potential role of intracellular communication. *Cancer Investigation* 1(6) 511-526.

Trosko 1983a JE, Jone C, Chang CC. Oncogenes, Inhibited Intercellular Communication and Tumor Promotion, Int. Symp. Princess Takamatsu Cancer Res. Und (US) 14:101-113

Trosko 1984 JE, Chang CC. Adaptive and nonadaptive consequences of chemical inhibition of intercellular communication. *Pharmacological Reviews*, 36(2)137S-144S

Trosko 1985 JE, Chang CC. Role of tumor promotion an affecting the multi-hit nature of carcinogenesis. *Basic Life Sciences (US)* 33:261-284

Tsymbol 2003 EY, Mryasov ON, LeClair PR. Spin-dependent tunneling in magnetic tunnel junctions. Evgeny Tsymbol Publications. Paper 19. Available at: <http://digitalcommons.unl.edu/physicstsymbol/19>

Ubeda 1983 A, Leal J, Trillo MA, Jimenez MA, Delgado JMR. Pulse shape of magnetic fields influences chick embryogenesis. *Journal of Anatomy* 137:513-36.

Upton 1961 AC, *Cancer Res* 21:717-729.

Walcott 1988 C, Gould JL, Lednor AJ. Homing Of Magnetized And Demagnetized Pigeons. *J Exp Biol* 134:27-41

Wang 2019 CX, Hilburn IA, Wu D-A, Mizuhara Y, Cousté CP, Abrahams JNH, Bernstein SE, Matani A, Shimojo S, Kirschvink JL. Transduction of the Geomagnetic Field as Evidenced from Alpha-band Activity in the Human Brain. *eNeuro* 18 March 2019, ENEURO.0483-18.2019; DOI: <https://doi.org/10.1523/ENEURO.0483-18.2019>

Weaver 1990 JC. Electroporation: A New Phenomenon To Consider In Medical Technology, in “Emerging Electromagnetic Medicine”. Monahan JC, Bentall RHC, O’Connor ME,eds., New York: Springer-Verlag New York, Inc., p. 81-101

Wei 1990 L-X, Goodman R, Henderson A. Changes In Levels Of C-MYC And Histone H2B Following Exposure Of Cells To Low-Frequency Sinusoidal Electromagnetic Fields: Evidence For A Window Effect. *Bioelectromagnetics* 11(4):269-272

Wiltshko 1991 W, Wiltshko R. Orientation In Birds. Magnetic Orientation And Celestial Cues In Migratory Orientation. *Experientia Suppl* 60:16-37

Winklhofer 2012 M. An avian magnetometer. *Science* 05/2012; 336(6084):991-2. DOI: 10.1126/science.1223786

Wutz 2018 A et al. Different levels of category abstraction by different dynamics in different prefrontal areas. *Neuron*. Vol. 97, February 7, 2018, p. 1. doi: 10.1016/j.neuron.2018.01.009.

Yaga 1993 K, Reiter RJ, Manchester LC, et al. Pineal sensitivity to pulsed static magnetic fields changes during the photoperiod. *Brain Res Bull* 30:153-6

Zapka 2009 M. et al. Visual but not trigeminal mediation of magnetic compass information in a migratory bird. *Nature* 461(Oct. 29):1274-1278. doi:10.1038/nature08528

Zusman 1990 I, Yaffe P, Pinus H, Omoy, A. Effects of pulsing electromagnetic fields on the prenatal and postnatal development in mice and rats: in vivo and in vitro studies. *Teratology* 42(2):157-170.

4. HEALTH EFFECTS OF EXTRA-LOW-FREQUENCY RADIATION.....	3
4.1. Origins	3
4.2. ELF Fields and Measurement	3
4.2.1. Earth's Fields	3
4.2.1.1. Electric Field	3
4.2.1.2. Magnetic Field.....	4
4.2.2. Physiological Fields	4
4.2.2.1. Natural Electric Field	4
4.2.2.2. Natural Magnetic Field.....	4
4.2.3. Man-Made Fields	4
4.2.3.1. non-natural Electromagnetic Fields.....	4
4.2.3.1. nnEMF computations	5
4.2.3.2. Decay of Fields with Distance.....	5
4.2.3.3. Electric and Magnetic Fields in the Streets	5
4.2.3.4. Field Values in the Home	6
4.2.3.5. Appliance and Tool Sources.....	7
4.2.3.6. Field Values in the Workplace	8
4.2.3.7. Electric Field Estimations Inside the Body	8
4.2.3.8. Magnetic Field Estimations Inside the Body.....	9
4.2.4. Electromagnetic Measurements	9
4.2.4.1. Dosimeters.....	9
4.2.4.2. Field Instruments	9
4.3. Extra-Low Frequency Bioelectromagnetics	10
4.3.1. Pre-Industrial Baseline	10
4.3.2. Generation of Free Radicals.....	10
4.3.3. Alterations to Water Structure.....	11
4.3.4. Alterations in Cell Death Mechanisms.....	11
4.3.5. DNA Folding changes.....	12
4.3.6. DNA damage: initiator role.....	12
4.3.7. Promoter or Co-Promoter Role	12
4.3.8. Inflammation and Immunity.....	12
4.3.9. Enzymatic Changes.....	13
4.3.10. Heat Stress Protein	13
4.3.11. Nervous System	14
4.3.11.1. Calcium Efflux from Nervous Tissue.....	14
4.3.11.2. Hypothalamus-Pituitary.....	14

4.3.11.3. Melatonin.....	14
4.3.11.4. Pineal Bio-Rhythm and Endocrine System.....	15
4.3.12. Inter-Field Interactions	15
4.4. Animal Evidence	15
4.5. Epidemiological Evidence	16
4.5.1. Genetic Changes and Aberrations	16
4.5.2. Cancer.....	16
4.5.2.1. Childhood Leukemia	17
4.5.2.2. Adult Leukemia	17
4.5.2.3. Brain Cancer	19
4.5.2.4. Breast Cancer.....	20
4.5.2.5. Other Cancers	20
4.5.3. Chronic Nervous System Diseases	20
4.5.4. Nervous System Function.....	20
4.5.5. Reproductive and Developmental Effects	21
4.5.6. Electromagnetic Hypersensitivity.....	22
4.5.7. Dirty Electricity.....	22
4.6. Occupational Situations	23
4.6.1. Schools	23
4.6.2. Cars.....	23
4.6.3. Portable and Laptop Computers	24
4.6.4. Electric Power Workers.....	24
4.6.5. Maglev Trains.....	24
4.6.6. Interference with Cardiac Pacemakers	24
4.7. Standards.....	25
4.7.1. 60-Hz Electric fields.....	27
4.7.1.1. Public Exposures	27
4.7.1.2. Occupational Exposure	27
4.7.2. 60-Hz Magnetic fields	28
4.7.2.1. Public Exposures	28
4.7.2.2. Occupational Exposure	29
4.8. Control Measures.....	30
4.8.1. Source Control for Power Utilities	30
4.8.2. Source Control for Schools and Home	31
4.8.2.1. Wire Twisting	32
4.8.2.2. Co-Axial Cable	32
4.8.2.3. Other Methods	33

4.8.3. Increasing Distance	33
4.8.4. Shielding	33
4.8.5. Field Cancellation	33
4.8.6. Practical Situations.....	34
4.8.7. Survey Procedures.....	34
4.8.8. DC Systems would Eliminate Risks.....	35
4.9. Risk Assessment.....	35
4.9.1. Risk Quantification	35
4.9.2. Prudent Avoidance	36
4.10. Summary	37
4.11. Appendix: a New DC Power Grid.....	38
4.11.1. Statement.....	38
4.11.2. AC and DC Magnetic Fields in the Environment	38
4.11.3. Advantages to the Power Industry.....	39
4.11.3.1. Transformers to Power Electronics	39
4.11.3.2. DC for Long Transmission Lines	39
4.11.3.3. DC for Distribution	41
4.11.3.4. DC for Consumption	41
4.11.3.5. DC for Computing.....	42
4.11.3.6. Implementation of the New DC Grid	42
4.12. Bibliography.....	42

4. HEALTH EFFECTS OF EXTRA-LOW-FREQUENCY RADIATION

The health effects of 50/60-Hz electric and magnetic fields (MFs) are providing intriguing data for environmental health scientists.

4.1. Origins

Loss of sex drive, disturbed digestion, headache and cardiovascular abnormalities were the symptoms described by Russian scientists among *high voltage workers* [Asanova 1966]. These reports prompted the Ministries of Energy and Electrification and of Health of the USSR to develop rules for the protection of workers. After these reports originating from the *Soviet Union* implied that exposure to high intensities of **electric** fields might have detectable *health consequences*, concern arose in the West around 1972. This was followed by indications [Wertheimer 1979; Milham 1982] that relatively weak levels of 60-Hz **MFs** were associated with an **increased risk of cancer**.

Effects of ELF fields rest on numerous epidemiological studies and on *in vitro* experiments, and the scope of the effects has increased steadily over time. For the electrical industry, these event shifted concerns from the traditional power grid impacts of shock, electromagnetic interference, ozone and audible noise, to the area of a variety of health effects.

In July 2001, the International Agency for Research on Cancer classified power frequency MFs as *possibly carcinogenic to humans* (Group 2B), based on the statistical association between higher level of residential MFs and increased risk for childhood leukemia [IARC 2001]. The agency also endorses the principle of *prudent avoidance* in relation to ELF MF exposures.

“Even where human evidence alone is used in the evaluations, the case study on ELF-EMF radiation showed that there is a risk that review bodies may overlook evidence of adverse effects in a collection of disparate studies that are individually inconclusive. Common sources of ELF-EMF are power lines, electrical wiring, and electric appliances. Whilst IARC (2002) based its “possible” human carcinogenicity (Group 2B) determination on only one cancer endpoint, childhood leukemia, a review of the same human evidence by the California Department of Health Services (CDHS) in 2002 identified three cancer outcomes as each warranting a “possible” carcinogen classification: childhood leukemia, adult leukemia, and adult brain cancer (for a detailed comparison see O’Carroll and Henshaw, 2008). Where evidence is too disparate to readily support meta-analysis, because of, for example, a lack of a well-defined common ELF-EMF exposure metric, then the statistical aggregation used by CDHS, but not by IARC in their 2002 reviews, can be useful in supporting precautionary policies that could address the more common adult cancers, in addition to the relatively rare childhood leukemias.” [Chartres 2022]

4.2. ELF Fields and Measurement

4.2.1. Earth’s Fields

4.2.1.1. Electric Field

The natural **dc** electric fields to which the atmosphere exposes us originate in planetary-scale *thunderstorm activity*, particularly intense in tropical regions such as the Amazon. The falling of water drops through the atmosphere charges the *earth negatively* with respect to the *ionosphere*. This activity maintains a **static fair weather field** of approximately **130 V/m** which is considerably affected or even reversed by local storms. Weather activity contributes fields at frequencies as

high as a few Hz. At 60-Hz, however, the field level contributed is minuscule (0.001 V/m) compared to the levels of the power grid.

The air is also mildly ionized by natural radiation, primarily from heavy elements in the ground. Radon diffuses into the atmosphere, and as a result, air ionization is higher above the continents than above the sea, as shown.

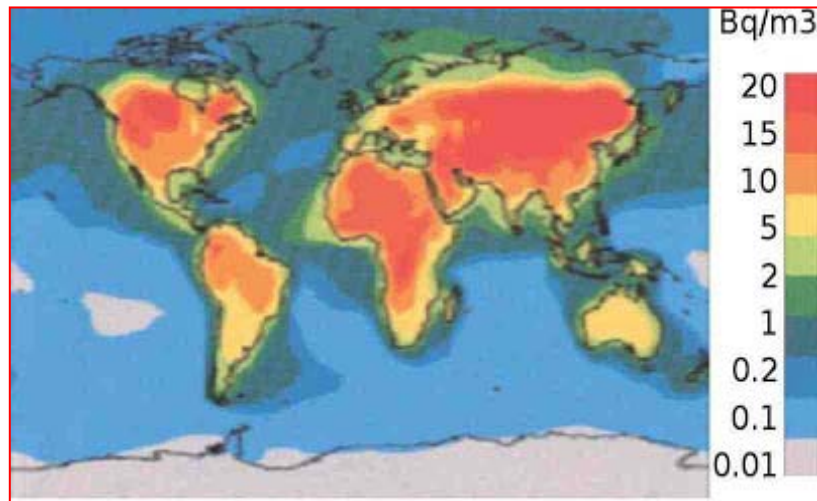

4.2.1.2. Magnetic Field

The solid inner core of Earth is surrounded by the outer core, a fluid layer mostly of iron and nickel. Flowing of liquid metal in the outer core can intensify electric currents and create Earth's MF, according to the *geodynamo theory*.

The static MF of the earth is 67 μT at the poles, 50 μT at middle latitudes and 33 μT at the equator. There are very small changes around this value, called micro-fluctuations, which would range in frequency to as much as 25 Hz. Intense solar activity and thunderstorms produce static fields from 0.03 to 0.5 μT .

4.2.2. Physiological Fields

4.2.2.1. Natural Electric Field

The most spectacular electrical events in the body are *nerve cell firings*, which have their strongest spectral components in the 2 kHz range. The integrated result of all neural activity can be detected in the *electroencephalogram*, which typically has frequency components *below 50-Hz*, and intensities of as much as **1 mV/m**, as measured on the scalp. Estimates of fields adjoining to firing nerve fibers range as high as **50 mV/m**. Another sustained internal signal source is depolarization of the heart. This has a spectral composition which is below 50-Hz, but a somewhat higher detectable intensity than the EEG, about **10 mV/m** at the surface of the chest.

4.2.2.2. Natural Magnetic Field

A Superconducting Quantum Interference Device (SQUID) magnetometer is capable of detecting the tiny biomagnetic fields associated with physiological activities in the body, such as the human heart beat, and encephalogram. Such fields are 100 times or more smaller than the MFs generated by electrical power systems.

4.2.3. Man-Made Fields

4.2.3.1. non-natural Electromagnetic Fields

The fields of technological origin are labeled non-natural Electromagnetic Fields (*nnEMF*). We are exposed to the 50-60-Hz man-made fields on a continuous basis in modern society. The fields come from a grid of conductors and from a myriad of powered devices.

The majority of our exposure comes from the fields associated with the electrical distribution system, with strong occasional

fields supplied by the electrical appliances that we use [Héroux 1988].

4.2.3.1. nnEMF computations

Using basic principles, it is possible to *calculate* the electric field due to an array of conductors carrying electric charges, and the MFs due to an array of currents in wires. At ELF frequencies, the electric and MFs must always be calculated separately. To help in calculations, there are ingenious methods

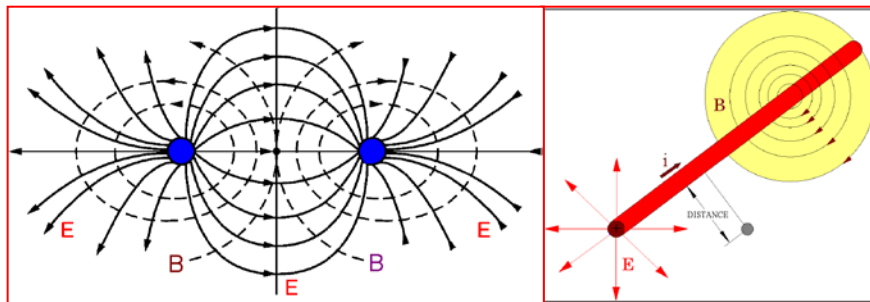

that are commonly used¹. In practice, advanced software is available for the calculation of ELF electric and MFs in various configurations, particularly those relevant to the projects of the electrical industry.

4.2.3.2. Decay of Fields with Distance

Beyond the intensity of the sources, decay with distance is a principal determinant of exposures. Since the sources of electric and MFs are often *electrical wires*, one should know that:

¹ Some problems of electric field computation can be considerably simplified by using the *method of images*. This technique consists in replacing the continuous surfaces defined as conductive boundaries by a number of electric point charges which approximate the field distributions of the shapes they replace. The larger the number of such charges, the longer the computation time, but the more accurate the results.

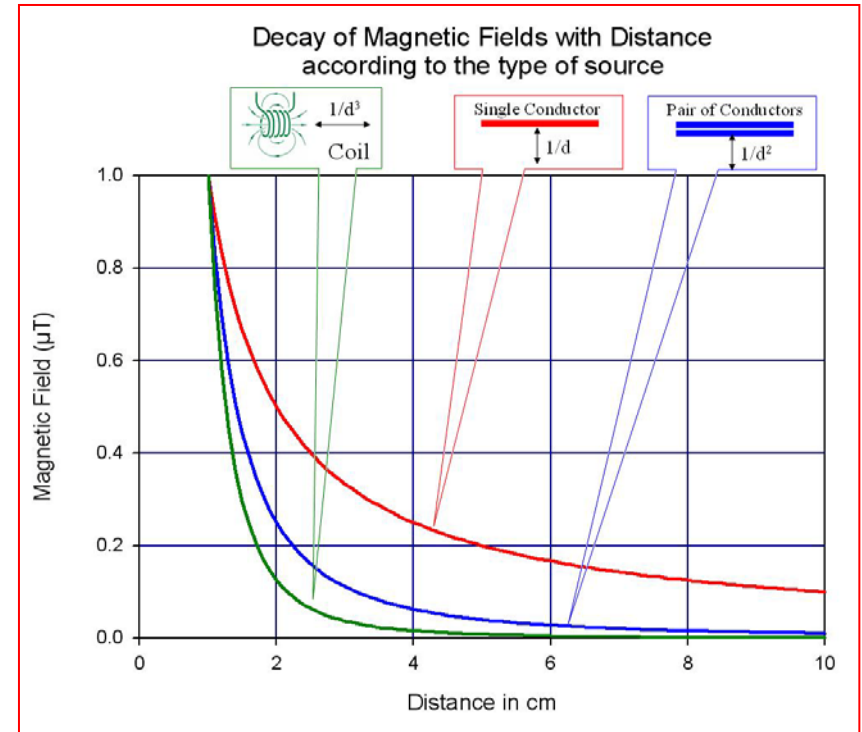

1. the electric and MFs from a **single line source** (or infinitely long single conductor) decay with distance as **1/d** (red in figure),
2. if the source is a **pair of wires** carrying opposite currents, the decay with distance is as **1/d²** (blue),
3. when the source of the field is a **coiled wire** or winding, the decay is as **1/d³** (green).

4.2.3.3. Electric and Magnetic Fields in the Streets

A survey of electric and MFs contributed by Hydro-Québec's distribution system [Héroux 1987] was carried out. It quantified the relative contribution of the utility's distribution system to exposures received from the electrical devices that we use in homes, commerce or industry. The network contribution turns out to be a major determinant of our overall

average exposure. The average residential ELF field is therefore determined primarily by outside sources, such as distribution lines and unbalanced ground return currents, which are determined by others. The most intense exposures are however determined by the devices that we use.

Problem 40. An ELF electric field meter is often held on the end of a perch. This is done:
 A: so that the instrument can be brought in safety near objects at very high voltages.
 B: so that the hygienist’s body does not disturb the field being measured.
 C: so that the instrument can be swept over large distances rapidly in order that quasi-simultaneous measurements can be obtained.

Electric fields are always less than 1 kV/m, with 160 V/m being typical under distribution line primaries, and are subject to spatial variations resulting from shielding by the many conductive objects (including buildings) in the environment.

Statistical distributions of MFs (nT) were determined for a variety of locations near Montreal in the following table.

Threshold of measurement are indicated by dashes.
The mode is the most probable value in the distribution.

nT	L90%	L50%	L10%	L1%	Mode
Mtl, Hochelaga 1	67	157	524	1327	131
Mtl, Hochelaga 2	29	141	300	612	96
Mtl, Ferrier-Lebeau	52	163	699	1506	82
Anjou	14	162	689	1405	---
Boucherville	---	117	376	857	135
St-Bruno	58	156	722	1429	85
Calixa-Lavallée	---	145	339	1025	153

La Présentation	---	266	539	765	135
Ste-Madeleine	25	172	375	809	216
Average	41	164	507	1082	129
Std Deviation (%)	51.5	25.2	33.0	31.3	34.0

From these measurements, the 60-Hz magnetic environment can be represented as a relatively weak milieu due to the distribution lines (regular crests of 1000 nT), punctuated by hot points of electrotechnical or domestic origin (1000 to 50,000 nT). People are subjected to the weak field virtually all the time, whereas exposure to the stronger sources is generally brief, unless the subject is occupationally exposed. There are strong variations over time, which depend on current consumption and distance from devices. Few structures, such as ferromagnetic materials and highly conductive metals, are able to substantially attenuate MFs. The human body is transparent to MFs, so exposure of all cells in the body to MFs is inevitable.

Cells react to ELF MFs even at low intensities [Delgado 1982; Ramirez 1983; Liboff 1984; Cameron 1985]. According to the table above, a person walking the streets would frequently be above the “biological activation” threshold. Li and Héroux [2013] detected robust changes in cancer cells at levels as low as 10-25 nT.

The fields used in most laboratory experiments are in many ways different from the ones in real exposures, which vary over time and in direction, and may combine many fields.

4.2.3.4. Field Values in the Home

US utilities (Zaffanella 1993) performed a survey of MF levels in homes. Summary results of the survey, in which spot measurements were taken in the middle of rooms, are shown below.

Magnetic Field in Homes:
 Median = **60 nT**, L5% = **290 nT**
 Largest part from the distribution system: **20 to 50 nT**
 2nd largest part from ground returns:
2 to 40 nT

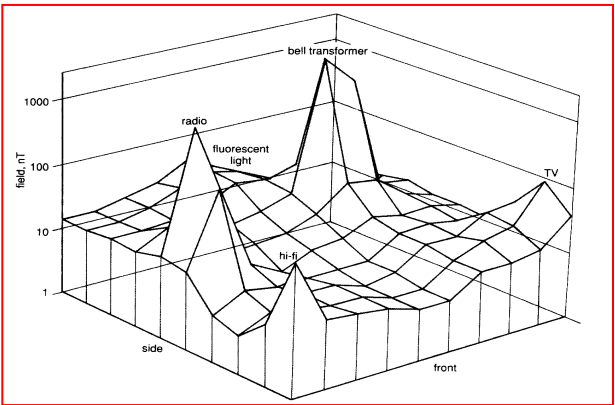

In the province of Québec, 18% of dwellings would exceed 200 nT. Data obtained in homes by Kaune [1987] found predictors (correlation

coefficient of 0.72) of the 24-hour average MF in a home. The predictors involve three characteristics of the transmission and distribution wiring within 43 m of a home: *presence of transmission lines, number of primary phase conductors, and number of service drops originating within the area.*

An example of mapping of the MF of the ground floor of a British house [Swanson 1994] is shown above.

4.2.3.5. Appliance and Tool Sources

Strong MF point sources are *vacuum cleaners, microwave ovens, small hand-held appliances, and electric tools.* These use light-weight, high-torque motors with small magnetic cores and little magnetic shielding, or large power transformers.

Fluorescent lights and their *ballasts* generate moderate field levels over large surfaces.² Quoted figures below [EPRI 1993] are approximations since the fields vary very rapidly with distance, and the exact value will vary according to construction details.

Electric fields in the home in locations remote from any appliance range from 0.5 to 10 V/m. Near appliances, especially those without a metallic casing, values can easily reach 100 V/m.

nT	B at 3 cm	B at 30 cm	B at 1 m
Color TV	2500-50,000	40-200	10-200
Range	6000-200,000	400-4000	10-100
MW Oven	75,000-200,000	400-8000	300-800
Hair dryer	6000-2,000,000	100-700	10-300
Clothes Washer	800-40,000	200-3000	10-200
Fluorescent Lamp	40,000-400,000	500-2000	10-300
Electric Razor	15,000-15,000,000	100-9000	40-300
	B at 1 cm	Body Avg.	B at 1 m
Old Electric blanket	10,000	1500	<100
New Model Electric blanket	1000	150	<10

² The conventional ballasts can be replaced by electronic ballasts, which attenuate magnetic fields substantially.

Electric field from	(V/m)
Electric blanket	250
Electric train	60
Food mixer	50
Hair dryer	40

4.2.3.6. Field Values in the Workplace

Exposed populations are **electrical utility workers** maintaining the electrical networks, as well as all activities that bring people close to transmission lines (farming operations), distribution lines (telephone utility employees), and powerful electrical equipment. Mean values as obtained in the Los Angeles area by London [1994] are as follows.

Job Type	Electric Field	Magnetic Field
Electrical	19 V/m	960 nT
Non-Electrical	5.5 V/m	170 nT

Dosimetric information relating to electric utility workers is available, as are electric field values associated with high voltage lines. Doses delivered during farming operations and welders are discussed later in this chapter.

4.2.3.7. Electric Field Estimations Inside the Body

Environmental electric fields induce electrical currents in the body, but are heavily attenuated as they penetrate into the human body, which is much more conductive than the surrounding air. The 60-Hz electric field intensities inside the body of a man are typically between 100,000 and 1 million times smaller than the field on the outside, since the body

circulates currents to compensate the external fields, and these currents also depend on anatomy [Geddes 1967].

The electric field lines around a conductive object tend to converge on it, entering at 90° to its surface. The ratio between the actual electric field on the top of a man's head to the *unperturbed field* is labeled the *enhancement factor* (it is equal to 18, at 60-Hz). This *unperturbed field* is the one that would be present in a given location in the absence of any human, animal or conductive object.

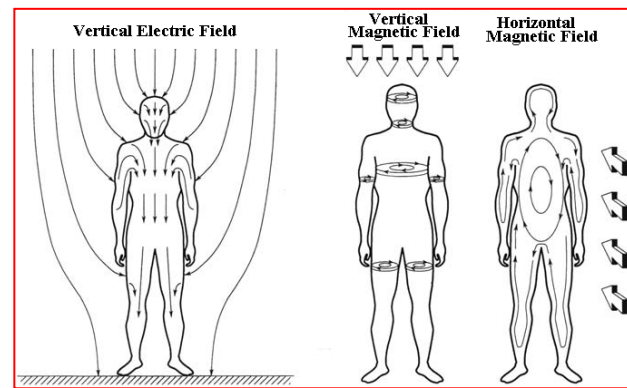

Enhancement factors can be determined for various locations on the surface of the body, or for a point on any physical object.

Because of this attenuation, many early investigators assumed that electric fields could not be bio-active (an engineering view). However, the electrical shielding provided by the body comes from the circulation of induced currents, and the presence of these **induced currents** cannot be viewed as innocuous. But the current patterns are enormously complex, because the body is not anatomically uniform either at the macroscopic or microscopic levels. At the macroscopic level, and at 60-Hz, induced current densities from electric fields are slightly higher in the core of the human body, while MF current densities peak in the periphery.

Because dosimetry is difficult, health effects of electric fields have received less attention than magnetic fields health effects.

4.2.3.8. Magnetic Field Estimations Inside the Body

By contrast, the magnetic fields from the environment penetrate living systems essentially unchanged, which means that every cell in your body is affected by the local magnetic field.

4.2.4. Electromagnetic Measurements

4.2.4.1. Dosimeters

A dosimeter [Héroux 1987a, 1987b, 1991] was developed which measured *electric, magnetic, and electrical transient fields simultaneously*. This unit was used by McGill's Department of Occupational Health to conduct an investigation into the connection between electromagnetic exposure and cancer occurrence in the population of Hydro-Québec, Ontario Hydro and Electricité de France workers. The pocket-sized unit was commercially produced by the firm Positron. EPRI in the US has supported the development of two dosimeters, named the AMEX and EMDEX [Bracken 1989].

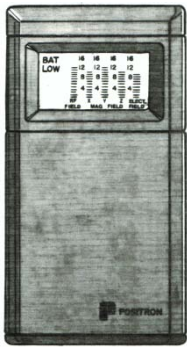

4.2.4.2. Field Instruments



The measurement of electric and MFs in occupational settings can be made using light, inexpensive, battery-operated instruments. In the ELF band (3-300 Hz), a number of small, practical instruments are available. The GQ EMF-390 at left can compile data every second for a full day and download to a computer through USB. The instruction

manual is in [Electromagnetism/EMF Instruments](#).

A sophisticated instrument is the electric and MF Narda EFA-300: 5 Hz to 32 kHz, ranges 5 nT-32,000 μ T and 0.7 V/m-100 kV/m, with spectral analysis (~25,000\$).

The advantage of the Narda is that it is sensitive enough to detect fields below the threshold of action of EMF MFs (25 nT).



More modern instruments, such as the Aaronia NF-5030, available at McGill, have also shifted their range of sensitivity (1 pT to 500 μ T) to include biologically relevant small fields.

Problem 41. A worker has been reading about Extra-Low-Frequency electric field exposure. He claims that fields higher than 10 kV/m are dangerous. He has also read that the “enhancement factor” for the top of his head is 18. Therefore, he refuses to work in fields higher than 555 V/m. Is he right? What would you tell him?

Problem 42. Explain the general nature of “window effects” in the context of electromagnetic biological interactions.

4.3. Extra-Low Frequency Bioelectromagnetics

Recognizing the biological effects of ELF radiation is politically difficult, because already deployed electrical power systems are involved. The literature has to deal with various frequencies, unexpected dose-responses (flat past a threshold), as well as a vast range of field exposures. Dosimetric questions, among which the determination of the biologically active field metric, have hindered lab and epidemiological efforts. MF effects may have extremely low thresholds, with a mostly flat, but uneven dose-response.

ELF MFs are coupled to specific physiological mechanisms, in contrast to other agents such as ionizing radiation, which alter molecules in a more global, stochastic fashion (ionization). This situation has enhanced the variability of responses between individuals, biological species and strains, making results more difficult to interpret.

Interactions of EM fields with living systems form a considerable literature, both in ELF [Anderson 1982, 1989] and in RF-MW. Keep in mind that modulated RF-MW have ELF components. At ELF frequencies alone, there are hundreds of reports of alterations of cell behavior under excitation by EM fields at intensities much below thermal [Goodman 1995]. It appears that metabolism, genetic and hormonal processes can be altered, with possible influences on growth, maturation, cancer, and chronic diseases.

4.3.1. Pre-Industrial Baseline

Scientific investigation of ELF EMF effects needs to provide a comparison between the fields that were present in the environment before technology developed, and the various ELF EMF exposures of interest. However, very few published

reports actually present this contrast, because elimination of the background exposure of MFs requires good precautions.

It is in fact only practical to experimentally obtain these pre-industrial fields in relatively limited volumes of space. The baseline environment should eliminate ELF MFs to levels of 1 nT). Of course, shielding requirements become more stringent when lower thresholds of action is assumed (0.01 nT).

For example, studies in an incubator would need to eliminate the MFs produced by the incubator itself, as well as the fields present in the laboratory environment, which the incubator wall itself only partly attenuates. For animal studies, very heavy cages would need to be designed.

In epidemiological studies, most investigations focus on the emissions of a specific application (power systems, cell phones, heaters), and neglect to take the complete (all frequencies) EM environment into account. Control populations with no technological exposures would need to be, say, 100 km from civilization to be “pristine”. Needless to say, such groups have many differences with the general public that make them a poor reference. Therefore, practically all EMF studies are actually a comparison between one field level and another, leading to a dazzling literature [Goodman 1979; Aarholt 1981; Ramon 1981; Williams 1982; Frazier 1982; Marron 1983; Liboff 1984; Winters 1984; Stevenson 1985; Dihel 1985; Goodman 1986; Phillips 1986; Phillips 1986ab; Noda 1987; Cain 1987; Kwee 1995].

4.3.2. Generation of Free Radicals

A consistent observation on ELF biological influences is the observation of pathological disturbance to organisms at levels much below any level capable of heating. This inevitably points to the fact that protecting against effects due to heating is irrelevant [García-Minguillán, 2019]. The disturbances to

organisms manifest as rises in Reactive Oxygen Species, as well as depletion of the enzymatic mechanisms that are naturally present to control such challenges [Lai, 2019]. There is a rich literature confirming that exposure to ELF MFs enhance ROS production [Kivrac 2017; Wang 2017; Yakymenko 2016].

4.3.3. Alterations to Water Structure

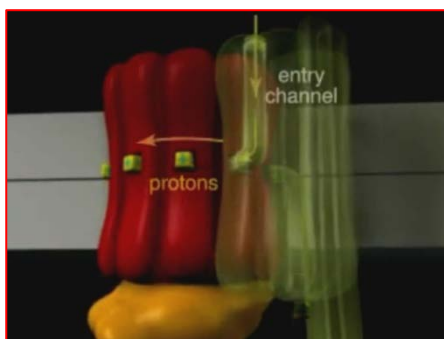

MFs as low as 25 nT have been shown to induce karyotype contraction [Li and Héroux 2013] in cancer cell lines *in vitro*. This phenomenon has been linked to an alteration in the structure of water [Semikhina and Kiselev 1981, 1988] that

impairs the flux of protons through the mitochondrial enzyme ATP synthase. ATP synthase is a critical enzyme that powers oxidative metabolism, and is structured like an electric motor powered by a flux of protons and counter-hopping electrons. The charges circulate through small channels filled with water. Variations in MF exposure would alter ATPS efficiency, altering the mitochondria's $\Delta\Phi_m$ up and down, which is meant to stay at a certain point (139 mV) to minimize ROS generation [Bagkos 2014, 2015].

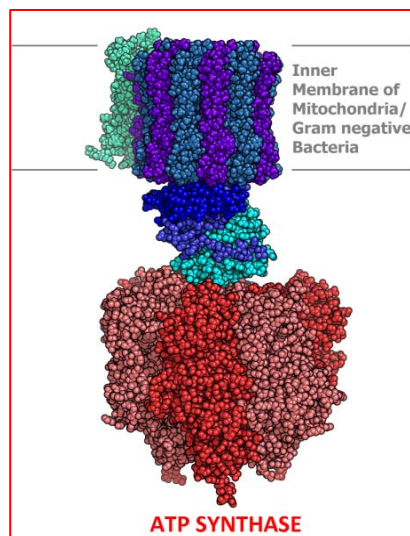

This disturbance of metabolism may be the cause behind the ability of environmental power-frequency MFs to increase the rate of leukemia in children (see 4.5.2.1 below), and to interact with other cancers, as well as general metabolism [Li 2012]. This would give ELF MFs the role of a metabolic disruptor.

Because the threshold of 25 nT is so low, the electrical power system would need to be substantially re-designed to avoid this effect. This could be done using dc instead of ac for transmission, distribution and consumption of electrical power (see 4.11). Ac transformers at the entry of many devices would be replaced with lighter solid-state units that would act as dc transformers, and the few devices in need of ac signals would be updated using shielded control circuits and co-axial cables and twisted pairs, which both radiate very little MF. The alteration in proton and electron transfer rates related to water structure changes could impact the many enzymes in human physiology that depend on such transfers. Other researchers have detected effects on metabolism (ERK1/2 phosphorylation) at levels as low as 150 nT [Kapri-Pardes 2017].

4.3.4. Alterations in Cell Death Mechanisms

By comparing the death rate of human cancer cells *in vitro* in the pre-industrial electromagnetic environment of the past with that of an electromagnetic environment typical of contemporary human exposures, it was shown that changes in MFs are a more powerful determinant of cell death than oxygen, and induce death by different mechanisms. Specifically, rates of necrosis, early apoptosis, and late apoptosis are different for oxygen and MFs. This has important implications for the reproducibility of *in vitro* biological experiments focusing on cell survival or metabolism, and for public health. The rates and mechanisms of cell death are

critical to many chronic human ailments such as cancer, neurological diseases, and diabetes [Li and Héroux 2019].

4.3.5. DNA Folding changes

Most DNA is in the classic Watson-Crick double helix. But throughout the genome, researchers have found knot-like structures made of hydrogen-bonded guanine tetrads known as quadruplexes. These structures are particularly prevalent near the oncogenes BRCA1, BRCA2, and MAP3K8, suggesting that tetrads may play a role in the development of cancer [Shivalingam 2015]. A group found more than 500,000 quadruplexes in human B lymphocytes [Chambers 2015]. Since MFs can alter hydrogen bond (proton) dynamics, this provides a mechanism linking magnetism with cancer.

4.3.6. DNA damage: initiator role

Enzymes such as catalase, superoxide dismutase and acetylcholinesterase [Glaves 2004] depend on proton transfers. Inhibition of antioxidant enzymes could contribute to the experimentally observed increases in free radicals, and would provide ELF MFs with an initiator function.

Using the Comet test, DNA damage was confirmed in many laboratory experiments [Ahuja 1997, 1999; Phillips 1997; Svedenstal 1999a,b; Zmyslony 2000] as well as by epidemiological observations in power workers [Hosseinabadi 2019; Zendejdel 2019]. Exposure to a 60-Hz MF at 10,000 nT for 24 hr causes a significant increase in DNA single- and double-strand breaks in rat brain cells. The effect further cumulates over 48 hr. Treatment with Trolox (a vitamin E analog) or 7-nitroindazole (a nitric oxide synthase inhibitor) blocks the effect, supporting an involvement of free radicals with MFs. Treatment with the iron chelator deferiprone also blocked the effects of MFs on brain cell DNA, suggesting iron involvement (Fenton reaction). Acute MF exposure increased

apoptosis and necrosis of brain cells in the rat, which may initiate the iron-mediated process that increases free radical formation in brain cells, leading to DNA strand breaks and cell death [Lai 2004].

4.3.7. Promoter or Co-Promoter Role

In the mid-80s, J. Phillips showed that EMFs can increase the proliferation of tumor cell colonies in soft agar. Evidence to support this line of thought has been accumulating even since, from various laboratories working on a diversity of cell lines (JB-6, HL-60, CHO-K1, CHO, Colo 205, Colo 320, ROS 17/2.8, C3H10T1/2). The promoter role of MFs has been illustrated as inhibition of differentiation (4000 nT) or stimulation of cell proliferation (100,000 nT) in a Friend erythroleukemia cell line, according to the intensity of application [Chen 2000]. This line of thought is compatible with the results of Li and Héroux [2013], since karyotype contraction, triggered by metabolic restriction, is believed to be an indicator of tumor promotion [Li and Héroux 2012].

4.3.8. Inflammation and Immunity

A variety of immune alterations have been observed.

Increases in lymphocyte counts and reductions in T-helper cells, reductions in levels of lactate dehydrogenase, cortisol, growth hormone and testosterone [Graham 1985]

Reduced ability of lymphocytes to destroy invaders after 48 hours of exposure to an electric field [Lyle et al. 1986, 1983], and significantly delayed occurrence of leukosis in AKR rats (who spontaneously develop leukemia), increased neutrophils, reticulocytes and reduced lymphocytes.

Exposure to ELF MFs changes the expression of some immune system genes, decreasing inflammation acutely, and increasing

it chronically [Molaei 2019]. This is compatible with increases in intracellular Ca^+ [Yang 2019].

In humans, it was shown that antioxidant vitamins can prevent the increase of proinflammatory cytokines induced by prolonged exposure to ELF-MFs [Hosseinabadi 2020].

Relatively large exposures to MFs (15 μT) increased IL-1 β and IL-6, white and red blood cell count, lymphocyte percentage and platelets, compared to unexposed (15 μT) [Hosseinabadi 2019b].

4.3.9. Enzymatic Changes

Section 4.3.3 documented the effect of ATPS through alterations in proton traffic, which would also be reflected in calcium efflux, to compensate for ATP losses. Alterations in proton transfer could also affect many other enzymes.

There is experimental evidence that EM fields can cause profound changes in intracellular enzymes [Byus 1984]. A case in point is *acetylcholinesterase*, a mostly membrane-bound enzyme which catalyzes the hydrolysis of the neuro-transmitter acetylcholine into choline and acetic acid. It plays an essential role in preventing the neurotransmitter acetylcholine from acting longer than necessary on a cell, and it provides for enough reactants to be available for synthesis of acetylcholine, when it is needed. Alterations of *acetylcholinesterase* activity have been detected as a result of 50-Hz electric field exposures [Anderson 1992].

Specific enzymes have been under investigation at ELF frequencies: N-acetyl-transferase and ornithine decarboxylase. N-acetyl-transferase is the enzyme that catalyzes the transformation of serotonin into melatonin, and altered concentrations of melatonin in exposed subjects could be explained in terms of ELF MF alteration of the efficiency of this enzyme.

Prothrombin time shortening in female rats is reported [Vallejo 2019].

4.3.10. Heat Stress Protein

Biological and chemical agents can often be quantified both in the environment and in the organism *after* exposure, as metabolites or antibodies. In contrast, physical agents such as sound, ionizing radiation, heat, and EM fields are not directly detectable post-exposure. But it was discovered in the 1970s that all organisms respond to mild elevations of temperature by synthesizing a set of moderately specific heat-shock proteins, and that these molecules are conserved through billions of years of evolution [Madreperla 1985].³

EM fields can, as well, activate protein synthesis, including HSP70 [Goodman 1988], the most evolutionarily preserved heat-shock protein. Heat-shock protein play a role in cellular maintenance, may be assigned to the defense of cells against toxic chemicals [Goff 1985], infection, antigen processing, ischemic injury and may have a role in cellular differentiation [Kurtz 1986], auto-immune diseases and apoptosis. It is also known that human heat shock transcription factor (HSF1) activates an abundant DNA-bound protein kinase [Dyran 1994]. Heat-shock proteins bind in the nucleus of cells, specifically in the nucleolus [Munro 1984, 1985].⁴ Field

³ The heat-shock-type response is a truly universal biological phenomenon intertwined with many mechanisms of signal transduction.

⁴ Heat-shock protein assist other protein through the membranes by grabbing them and unfolding them, thus presenting a less globular, straightened protein [Frydman 1994]. Without such heat-shock proteins, organelles such as mitochondria, which do not synthesize all of their protein indigenously may starve and die, the needed protein accumulated outside their membrane. HSP70 reversibly binds to heat-unraveled protein, thus avoiding denaturation. The HSP70 response of hepatocytes declines markedly with age at the transcriptional level. Caloric restriction, which retards aging, reverses the age-related decline in HSP70 expression [Heydari 1993].

strengths similar to those in the home and workplace increase production of a protein that regulates proliferation and development of cells destined to become bone, and stimulate the maturation of cells [Aaron 1999].

4.3.11. Nervous System

In vitro tests have documented effects on neural progenitor cells at high magnetic field exposures (1000 μ T) for 5 days, suggesting possible connections with autism, Parkinson's disease and dementia [Özgün 2019].

4.3.11.1. Calcium Efflux from Nervous Tissue

Adey and Blackman [Bawin 1975; Blackman 1979] used weak electro-MFs to study *calcium efflux*. After nerves containing radioactively labeled calcium have been stimulated by EM fields, and the exposure stopped, the calcium is released in increased amounts, indicative of calcium leakage (inhibition of Ca pump), with critical consequences for cellular growth and function [Gavalas-Medici 1977; Kercher 1980; Hansson 1983; Albert 1984; Gundersen 1985; Ossenkopp 1988; Blackman 1993; Seegal 1989]. The effect occurs within a **frequency-amplitude window**.

4.3.11.2. Hypothalamus-Pituitary

There is a rich eastern literature describing effects on the hypothalamus and pituitary of low-levels of EM radiation [Mikolajczyk 1987, 1991]. The hormonal system is adaptive, and characterized by central control in the hypothalamus. Neuro-secretory cells in the hypothalamus discharge into the portal circulation, inducing the corresponding tropic hormones in the pituitary, which in turn activates peripheral endocrine glands. Hormones of the peripheral glands exercise a feedback inhibition of neurohormones in the hypothalamus and tropic hormones in the pituitary. Hypothalamic stimuli and secretion

of LH-RH and gonadotropic hormones LH and FSH in the pituitary have the same *pulsed pattern*. The hormonal system is responsible for growth, reproduction, metabolism, and the water-mineral balance. Experimental studies primarily in the East confirmed the hypothesis that the hypothalamus and pituitary are the primary elements in the endocrine system responses to EMF: changes in the growth rate, LH, FSH and GH levels in the hypothalamus; and Na, K, Ca, and water levels in the brain, submandibular salivary glands and kidneys.

4.3.11.3. Melatonin

The discovery of the suppression of melatonin secretion from the pineal gland by ELF electro-MFs [Dixey 1982; Welker 1983] has provided many possible couplings between MF exposure and cancer [Reiter 1992; Liburdy 1992]. Cancer could be induced by stimulation of cell proliferation directly, by elimination of melatonin's suppression of estrogens, or by stimulation of oxidative damage, possibly mediated by iron.

Melatonin has the ability to inhibit the body's production of estrogen [Kato 1993; Stevens 1987, 1992] and directly inhibit the proliferation of human breast cancer cells in culture [Blask 2005]. When exposed to a chemical carcinogen, rats subjected to MFs developed more mammary tumors than did unexposed controls [Beniashvili 1991], a finding repeated in Germany [Mevisen 1993]. A repeatable result has been the blocking by 1200 nT magnetic fields of melatonin's ability to check the growth of MCF-7 breast cancer cells [Ishido 2001].

Melatonin suppresses the transformation of linoleic acid into 13-HODE [Sauer 1999], which stimulates cell proliferation. The growth of multiple tumor types can be suppressed by the presence of melatonin at certain times of the day [Blask 1999]. Melatonin is also widely known as a potent anti-oxidant and anti-aging drug [Tan 1993, 1993a; Hardeland 1993; Reiter 1993; Peoggeler 1993; Rozenywaig 1993]. Therefore, its

chronic suppression may make subjects more susceptible to many cancers, including breast cancer.

Xenoestrogenic Chemicals

DDT, heptachlor, atrazine
petroleum by-products
Poly-Chlorinated Biphenyls, diethylstilbestrol
Polycyclic Aromatic Hydrocarbons

Melatonin Suppressors

- **magnetic fields**
- beta-blocker drugs
- bright lights at night
- combustion by-products

A review of the literature on the antioxidant melatonin, naturally produced by the body, showed that exposure to MFs decreased melatonin production when the ac fields are below 30 μ T [Bouché 2019].

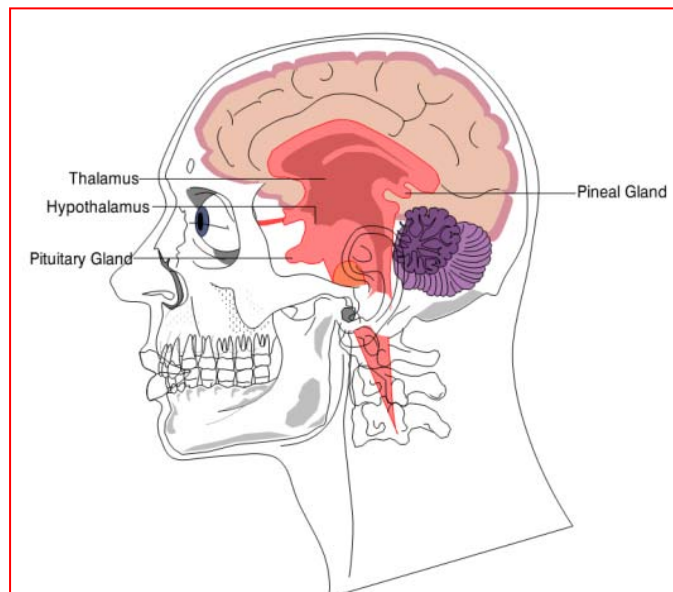

4.3.11.4. Pineal Bio-Rhythm and Endocrine System

Electric utility workers exposed to long-term, very strong electro-MFs are apparently affected by a type of jet-lag syndrome, due to an alteration of the circadian rhythm of the pineal gland, but in practice, few electric utility occupations have such strong exposures. The alteration of pineal melatonin rhythm [Ehret 1980; Russell 1982; Duffy 1982], and perhaps of serotonin rhythm [Vasquez 1988; Lymangrover 1983; Sulzman 1986], have been observed in some animals; other hormones may be involved [Free 1981].

After 3 weeks of exposure to electric fields, the pineal gland of rodents showed a suppression or shift in the transformation of serotonin to melatonin [Wilson 1986, 1980; Anderson 1982, 1989]. **No dose-response** was obtained in a range of twenty-fold of field strength.

4.3.12. Inter-Field Interactions

In many instances, biological effects of electromagnetic waves have been shown to interact with, or be activated by other electromagnetic variables. Among the modifiers of the ELF MF, one finds the geoMF (static) and the electric field, oriented either parallel or perpendicular to one another [Lednev 1991].

4.4. Animal Evidence

From a number of animal experiments, ELF MFs act as a cancer promoter. We provide below a recent example of EMF MFs combined with ionizing radiation [Figure 7 from Soffritti 2015]. Rats, which received a single low-dose of gamma radiation early in life and were exposed to MFs for their entire lifetime, developed higher than expected rates of three different types of cancer: breast cancer and leukemia/lymphoma, as well as an extremely rare and obscure tumor, called malignant schwannoma of the heart. This study confirms the old

epidemiological observations of Milham, Wertheimer, Matanoski and Cardis. Schwannomas were recently reported in the National Toxicology Program study on cellular phones (see chapter 5).

The Soffritti study used an initiation-promotion protocol. Male and female Sprague-Dawley rats were exposed for all their lives to 50 Hz MFs at an intensity of either 20 μ T or 1,000 μ T. At the age of six weeks, they each received a single moderate 0.1 Gy dose of gamma radiation, a known cancer agent. The researchers observed

- (a) a significant dose-related increased incidence of mammary adenocarcinomas [breast cancer] in males and females in particular in males exposed to 20 μ T plus 0.1 Gy and in females exposed to 1,000 μ T plus 0.1 Gy;
- (b) in males a significant dose-related increased incidence of heart malignant schwannomas with a significant increase among males exposed to 20 μ T plus 0.1 Gy (statistically significant) and to 1,000 μ T plus 0.1 Gy; and
- (c) a significant increased incidence of hematopoietic neoplasias [leukemia and lymphoma] in males treated at 1,000 μ T plus 0.1 Gy.

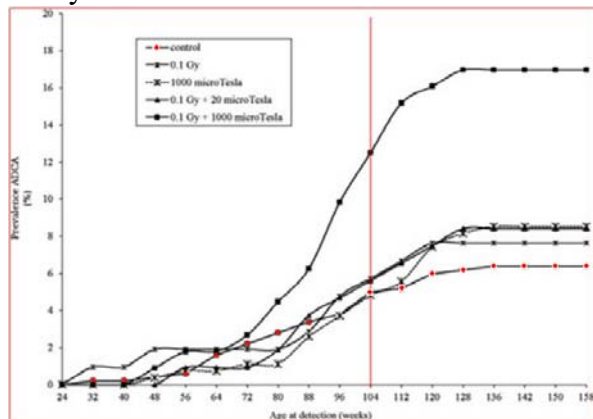

Cumulative incidence of breast tumors among female rats over time.

4.5. Epidemiological Evidence

Detailed assessment has found ELF MFs to be associated with childhood leukemia [Coleman 1990; Grellier 2014].

In humans, there is evidence that fields suppress melatonin in incubators for pre-natal babies [Bellieni 2012], and that in power plant workers, antioxidant vitamins, particularly vitamin E, can counteract the DNA damage produced by the fields [Hosseinabadi 2020a].

4.5.1. Genetic Changes and Aberrations

Nordenson [1984, 1988] found an increased incidence of *chromosomal aberrations and micronuclei in the blood of electrical utility workers*. These results correlate with *in vitro* studies of lymphocytes exposed to transient electrical discharges. Some have reported chromosomal aberrations and sister-chromatid exchange *in vitro* following EMF exposures. MFs impact genetic expression at various field intensities in the spleen and thymus of rats [Mahaki 2019a]. Skyberg [1993] provides a review and Jbireal at more recent one [2018].

4.5.2. Cancer

Epidemiology contributed 40 residential and 96 occupational studies of carcinogenicity related to MFs between 1979 (Wertheimer) and 1996 [for example, Fulton 1980; Wertheimer 1982; Milham 1982; Wright 1982; McDowall 1983; Coleman 1983; Swerdlow 1983; Varego 1983; Pearce 1985; Calle 1985; Spitz 1985; Lin 1985; Milham 1985; Olin 1985; Tomenius 1986; Gallagher 1989;]. Most of the studies suffer from a weakness, that of having *estimations of electric and magnetic exposure based on surrogates* (wire code, employment title). But the hand of industry in trying to evade science has been made clear [Carpenter 2019].

4.5.2.1. Childhood Leukemia

Leukemia is the most common childhood malignancy, peaking in the age group of 2 to about 5 years, accounting for about one third of childhood cancers.

Wertheimer and Leeper who found in 1979 that cancer deaths (primarily leukemia) in children less than 19 years of age in the Denver Colorado area were correlated with the presence of high MF *wire configurations* in the vicinity of the residences. The retrospective study was based on 344 fatal cases (1950-1973) and an equal number of controls. In a subsequent publication [1982], these authors reported a similar association for the incidence of adult cancer (1179 cases). In a 1988 follow-up study, Savitz et al essentially confirmed the findings of Wertheimer. Feychting [1992, 1993] of the Swedish Karolinska Institute found in a case-control study that children exposed to higher MFs in their homes had close to four times the expected rate of leukemia. Their exposure assessment (see results below) was the most detailed ever attempted, reconstructing long-term MF exposures for those living next to high voltage power lines.

Child Leukemia	Relative Risk	Relative Risk
Control	> 200 nT	> 300 nT
1	2.7*	3.8*
Trend Test	p = 0.02	p = 0.005

In June 2001, following two pooled analyses of childhood leukemia studies, the International Agency for Research on Cancer classified ELF MFs as 2B (*possibly carcinogenic to humans*), based on consistent statistical associations of high level residential MFs with a doubling of risk of childhood leukemia. **Increased risk for childhood leukemia starts at**

levels almost one thousand times below the safety standards favored by industry.

Leukemia risks for young boys are reported to double at only 140 nT and above [Green 1999]. Most other studies combine older children with younger children (0 to 16 years), so that risk levels do not reach statistical significance until exposure levels reach 200 or 300 nT.

Epidemiologic studies have consistently shown increased risk for childhood leukemia associated with ELF MFs [Feychting 2005; Kokate 2016].

Núñez-Enríquez et al [2020] provide the following dose-response for childhood acute lymphoblastic leukemia.

Magnetic Field	Adjusted Odds-Ratio
200 nT	1.26 (95% CI: 0.84-1.89)
300 nT	1.53 (95% CI: 0.95-2.48)
400 nT	1.87 (95% CI: 1.04-3.35)
500 nT	1.80 (95% CI: 0.95-3.44)
600 nT	2.32 (95% CI: 1.10-4.93)

Children who have leukemia and are in recovery (prospective study) have poorer survival rates if their ELF exposure is between 100 and 200 nT in one study; over 300 nT in another study [Foliart, 2006; Svendsen, 2007].

4.5.2.2. Adult Leukemia

Leukemia in adults is rare (1/10,000 per year) and often fatal. Little is known about the actual causes of the various forms, acute myeloid, chronic myeloid, acute lymphocytic and chronic lymphocytic. Large exposures to ionizing radiation and benzene are known risk factors. About half of studies dealing with EMF exposure have found higher rates of leukemia in the exposed [Kheifets 1995]. The association appears stronger for acute leukemia, but chronic forms are sometimes found.

In study using 1950-1982 data from Washington State, Milham [1982] indicated an increase in deaths (proportional mortality ratio) due to leukemia in 486,000 men whose occupations were associated with electric or MFs. The groups considered to have electromagnetic field exposure were: *electrical and electronics technicians, radio and telegraph operators, radio and television repairmen, telephone and power linemen, power station operators, welders, aluminum reduction workers, motion picture projectionists and electricians*. The highest PMR (1.62) increases were found for leukemia for 8 of the 9 exposed occupations, and for the “other lymphoma” category in seven (1.64).

Wright [1982] used *proportional mortality ratios* derived from the Cancer Surveillance Program registry for Los Angeles County (1972-1979). He found a significantly higher incidence of acute leukemia among power linemen, and of acute myelogenous leukemia among power linemen and telephone linemen.

McDowall [1983] found a slight trend for acute myelogenous leukemia incidence in electrical occupations in England and Wales. Comparable findings were reported by Coleman [1983]. A number of other studies will only be referenced here: [Flodin 1986, Stern 1986, Cartwright 1988, Bastuji-Garin 1990, Juutilainen 1990, Tönqvist 1991 and Guénel 1993].

An excess of leukemia among 546 male electrical workers was noted in a case-control study (1979-1983) conducted in New Zealand [Pearce 1985]. There were 2184 controls. An odds ratio of 1.7 was found in occupational groups involving potential exposure to electric and MFs.

A study (below) by Floderus [1992] of the Swedish National Institute of Occupational Health showed that men exposed to MFs had increased incidence of chronic lymphocytic leukemia and leukemias.

Chronic Lymphocytic Leukemia

<0.150 nT	160 - 190 nT	200 - 280 nT	> 290 nT
1	1.18	2.46*	3.08*

Leukemias

< 150 nT	160 - 190 nT	200 - 280 nT	> 290 nT
1	0.94	1.23	1.63*

McGill’s Department of Occupational Health has conducted a survey of cancer incidence among electric utility personnel [Thériault, 1994], a pool of 223,000 men observed over the period 1970-1989. Using a case-control design, the results were produced from 4,151 new cases of cancer.

This study was followed by another performed on U.S. utility workers by Savitz [1995]. In a cohort of 138,000 men who had worked for utilities between 1950 and 1986, a compilation was made of the causes of death, and individual cases were assigned to 28 exposure groups using about 3,000 workshift MF measurements. The study controlled for solvents and polychlorinated biphenyls, which are associated with leukemia and brain cancer.

>3100 nT-yrs (median)	Low 95% CI Limit	Odds Ratio	High 95% CI Limit
Acute Non-Lymphoid Leukemia	1.07	2.41	5.44
Acute Myeloid Leukemia	1.20	3.15	8.27

>200 nT mean exposure	Low 95% CI Limit	Odds Ratio	High 95% CI Limit
Acute Non-Lymphoid Leukemia	1.00	2.36	5.58
Acute Myeloid Leukemia	0.79	2.25	6.46

Higher exposures to MFs were not related to a higher risk of total leukemia or to any subtype of leukemia in this study, although chronic lymphocytic leukemia was associated with work in an exposed job. In contrast, brain cancer mortality was increased for exposed men and specifically for linemen and electricians (relative risks around 1.5 for five or more years in those jobs).

When MF exposure level was assessed, a stronger association was found. Compared to the lowest exposure group, the middle exposure groups had relative risks around 1.5 and the highest group had relative risks of 2.3 to 2.5, somewhat more than double the risk in the lowest category. Many other studies have been conducted since [Villeneuve 2000; Huss 2018]

4.5.2.3. Brain Cancer

Brain cancer has an incidence of about 6 per 100,000 per year. It results from transformation of cells within the brain or spinal cord. Few causes are known.

Lin [1985] found, in a case-control study of men in electricity-related occupations, a significantly higher incidence of primary brain tumors (gliomas and astrocytomas).

A case-control investigation of the association between childhood neuroblastoma and paternal occupation was conducted by Spitz [1985]. A significant odds ratio was found (2.13) for fathers in occupations exposing them to electroMFs. For electronics workers specifically, the odds ratio was **11.75**.

A case-control study conducted by Tomenius [1986] in the county of Stockholm (716 matched cases) investigated the fields in the homes of tumor patients. Tumor dwellings showed a significant excess of visible electrical constructions. A significant relationship was found for the nervous system tumor group. The tumor rate for dwellings with visible 200 kV

wires increased **2** fold for birth dwellings and **2.3** fold for diagnosis dwellings.

Thériault [1994] found that workers with the highest cumulative exposure to MFs had an elevated risk of brain cancer (1.95).

Savitz [1995] reported a consistent association between MFs and brain cancer (2.3), with evidence of a dose-response relationship.

Li reported results suggestive of an association between maternal occupational ELF-MF exposure and certain brain tumors in their offspring [Li 2009].

Turner reported [2014] positive associations between cumulative ELF 1 to 4 years before the diagnosis/reference date and glioma (odds ratio (OR) > 90th percentile vs. < 25th percentile, 1.67; 95% confidence interval (CI), 1.36–2.07) and, somewhat weaker associations with meningioma (OR > 90th percentile vs. < 25th percentile, 1.23; 95% CI, 0.97–1.57). This suggest that occupational ELF exposure may play a role in the later stages (promotion and progression) of brain tumorigenesis.

A case-control study on occupational exposure to extremely low-frequency MFs and glioma risk using cumulative exposure and astrocytoma grade IV (glioblastoma multiforme) in the time window 1-14 years gave an odds ratio of 1.9 and in the time window 15+ years an OR of 0.9 in the highest exposure categories 2,750+ and 6,590+ nT years, respectively [Carlberg 2017]. No association was found for acoustic neuroma [Carlberg 2020].

4.5.2.4. Breast Cancer

Incidence of breast cancer in women is 1 in 1000 annually, and increasing. The etiology of the majority of cases is unknown. The reduction of melatonin levels caused by MFs suggests a link with female breast cancer, due to estradiol over-exposure. Tynes and Andersen [1990] found a significant 2.1 RR of breast cancer in Norwegian men potentially exposed to EMF, while Demers [1991] found a RR of 1.8.

Positive associations have been observed in rats between exposure to MFs, reduced melatonin levels, and increased incidence of mammary tumors [Löscher 1995], thereby confirming the physiologic pathway [Mevissen 1995]. A case-control study was conducted among women older than 19 in electrical occupations, who died of breast cancer between 1985 and 1989 in 24 US states. After adjustment for age, race and social class, the women in electrical occupations showed a higher risk from breast cancer, in the table below [Loomis 1993].

Women's Breast Cancer	Odds Ratio	Confidence Interval
Electrical Workers	1.38	1.04-1.82
Electrical Workers, 45-54 yrs old	2.15	1.17-3.98
Electrical Workers, managers & professionals	1.84	0.98-3.46
Engineers	1.73	0.92-3.25
Technicians	1.28	0.79-2.07
Telephone line installers	2.17	1.17-4.02

A massive long-term study in Sweden found no support for a connection between ELF MFs and breast cancer [Forssen 2005]. However, there may be a connection to electric lighting [Blask 2005] because of melatonin suppression.

4.5.2.5. Other Cancers

The table below summarizes some epidemiological associations between MFs and other cancers.

Author	Tumor
Tynes, 2003	Melanoma.
Weiderpass, 2003	Stomach, pancreatic cancers.
Villeneuve, 2002	Glioblastoma multiforme.
Hakansson, 2002	Kidney, pituitary gland, biliary passages, liver cancers, astrocytomas.

4.5.3. Chronic Nervous System Diseases

Epidemiological investigations of ELF MFs have linked them to Alzheimer's disease [Sobel 1995] and amyotrophic lateral sclerosis [Davanipour 1995; Koeman 2017; Filippini 2020; Jalilian 2020]. Finnish and US researchers have discovered that seamstresses and tailors run a three-fold risk of Alzheimer's disease, possibly from decades of exposure to the MFs from sewing machines [Sulkava 1996]. Other studies find some link with many chronic neurodegenerative diseases at the same time [Gervasi 2019].

The following incidence rate ratios for the highest level of exposure (≥ 1000 nT) of 1.44, 1.78, 1.40 and 1.34 were reported for dementia, motor neuron disease, multiple sclerosis and epilepsy, respectively [Pedersen 2017].

4.5.4. Nervous System Function

Effects on more subtle functional impacts of EMR seems to be emerging [Prichard 2019; Deruelle 2020].

There has been a long string of investigations into increased reaction time and other variables in human subjects exposed to electromagnetic radiation [Medvedev 1976; Shestakov 1982; Graham 1985, 1987; Bonnell 1986; Ghadamgahi 2016].

It has also been proposed that EMR can enhance **depression**, suicide, anger, rage, violence, homicide, and neurological disease [Cherry 2002], whereas more recent studies find depression, stress, anxiety, job burnout and poor sleep quality [Hosseinabadi 2019a, 2020b].

4.5.5. Reproductive and Developmental Effects

Infertility is increasing at an alarming rate in human populations, halved in the last 40 years, but no one knows why [Levine 2017]. EMFs have been associated with alterations of the reproductive system: male germ cell death, the estrous cycle, reproductive endocrine hormones, reproductive organ weights, sperm motility, early embryonic development, and pregnancy success [Gye 2012].

Significant associations were observed between female infertility and living less than 600 m from a power line [Esmailzadeh 2019, 2019a].

There have also been a number of animal studies which have suggested a link between MFs and **development**. Slight developmental alterations are documented; birth defects were observed in specific experiments, while others showed no effects [Nordstrom 1983; Bonnell 1986; Sikov 1987; Handcock 1992; Lindbohm 1992; Li 2002; Wang 2016; Sadeghi 2017]. In humans, prenatal ELF MF was associated with decreased fetal growth in girls, but not in boys [Ren 2019]. Miscarriage risks have been reported in proximity of power lines [Ebadi 2020].

Wertheimer [1986] investigated the effect of electric blankets and heated waterbeds, using a retrospective study correlating *fetal growth* and *abortion rate* with month of conception. *Low birth weight infants were born more frequently in the exposed group (46%) than in control groups (21%)*. Congenital defects appeared at a rate of 1 in 335 (0.3%) in the unexposed and at a

rate of 5 in 193 (2.6%) in the exposed. MFs from electric blankets are about 400 nT. Water beds rate about 1,500 nT.

When measured on typical days for 913 pregnant women, MFs were associated as below for **miscarriage** risk [Li 2017].

99th Percentile MF (nT)	Total N	Miscarriage N (%)	cHR (95% CI)	aHR (95% CI)
1st quartile, <250 nT	106	11 (10.4%)	Ref	Ref
2nd quartile, 250-360 nT	116	32 (27.6%)	2.87 (1.45–5.70)	3.29 (1.59–6.79)
3rd quartile, 370–620 nT	119	31 (26.1%)	2.70 (1.36–5.39)	3.01 (1.48–6.12)
4th quartile, ≥630 nT	112	21 (18.8%)	1.83 (0.88–3.79)	2.02 (0.95–4.28)

cHR: crude (unadjusted) hazard ratio; aHR: adjusted hazard ratio.

Another concern relating to **teratology** (malformation of newborns) was materialized at about the same period, partly based on reports from Sweden [Nordstrom 1983] on incidence of malformations in the children of High Voltage switchyard workers and on a *miniature swine study* [Sikov 1984, 1987]. The use of electrical appliances, which would provide short exposures of high intensity, were reported to increase congenital heart disease [Zhao 2019].

Power frequency MFs have been linked with increased incidence of asthma in offspring: every 100 nT increase in average exposure of the mother during pregnancy yielded a 15% increase in asthma rate. Fields of 200 nT and above have a 3.5 times rate of asthma [Li 2011].

Children of mothers exposed to higher levels of MF had more than twice the risk of ADHD (adjusted hazard ratio, 2.01; 95%CI, 1.06-3.81). The association was stronger for ADHD that persisted into adolescence (>12 years of age), with an adjusted hazard ratio of 3.38 (95%CI, 1.43-8.02). When the subtypes of ADHD were examined, the association existed primarily for ADHD with immune-related comorbidities (asthma or atopic dermatitis), with an adjusted hazard ratio of 4.57 (95%CI, 1.61-12.99) for all ADHD cases and an adjusted

hazard ratio of 8.27 (95%CI, 1.96-34.79) for persistent cases of ADHD [Li 2020].

4.5.6. Electromagnetic Hypersensitivity

Electromagnetically sensitized people develop symptoms and health problems when exposed to ELF or RF-MW fields. Prevalence is less than 1.5% for severe cases, 1.5 to 5% for moderate cases and 5 to 30% of the population for mild cases [Bevington 2019].

This syndrome is known as electrical hypersensitivity (EHS) and is often coupled with *chemical* hypersensitivity, suggesting that chemicals and fields may share biological targets.

The syndrome can be triggered by large exposures to field or chemicals or by chronic overexposures inducing ROS generation.

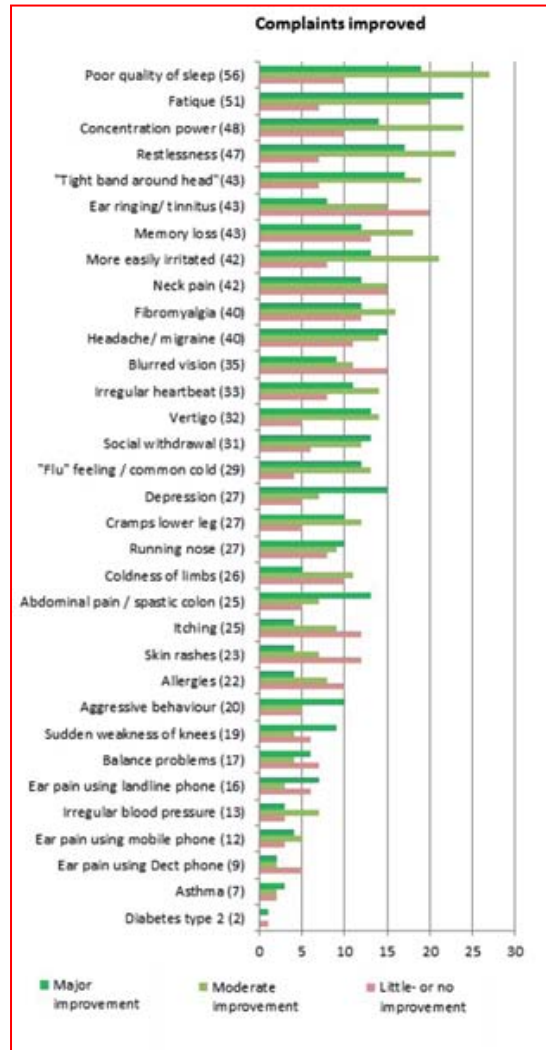

Victims usually report more than one symptom, and may be sensitive to specific field types. Reducing exposures seemed favorable, but there is no single EMF reduction measure which satisfied every individual. The reduction methods that proved most effective included replacement of DECT phones by corded phones, reducing use of mobile phones, disconnecting WiFi routers, and reducing PC and TV time. Other protection methods included removal of energy saving lamps, earthing electrical devices, reducing personal computer radiation, use of shielded electrical cables, conductive wall paint, shielded clothing, EMF reflecting glass panes, replacing thermostats and disabling electrical beds and chairs. Some sufferers get relief from installation of demand switches which turn off all electrical power except for specific times, filtering “dirty electricity”, earthing of electrical outlets and wiring [Schooneveld 2015].

But some EHS people are extremely sensitive to very small fields, suggesting involvement of the immune system. Therefore EHS people sit at the bottom range of sensitivity, far below fields in the common environment, and even further below the heating thresholds promoted by industry. From a 708 adult sample of the general population, it seems that a subgroup of the population is different from the whole, as characterized by its perception threshold of 50-Hz electric currents [Leitgeb 2003]. Some individuals appear physiologically disturbed by 60-Hz electric fields [McCarty 2011].

4.5.7. Dirty Electricity

When lower dc voltages are generated from power outlet ac voltages (120 or 220 V) using semi-conductors, harmonics of the base frequency (50 or 60-Hz are generated, generally ranging from power frequencies to 100 kHz, reaching to as much as 1 MHz. Emissions of this kind are becoming prevalent

in the environment, because of the use of switched mode power supplies. There has been relatively little research on this subject [de Vocht 2010]. LED lighting is also a source, although some designs seem to emit relatively little radiation [Milham 2018].

Electrosmog reduction has been reported in 64 patients to improve the symptoms of chronic inflammatory and autoimmune diseases: a silver-threaded cap designed to protect the brain and brain stem from microwave resulted in 90% reporting “definite” or “strong” changes in their disease symptoms [Marshall 2016].

4.6. Occupational Situations

Very high exposures are often relatively rare and brief, and some specific such cases will be mentioned below. MFs around induction furnaces and heavy motors may be as high as 100 μ T, but rarely exceed 1,000 μ T.

4.6.1. Schools

Because Wertheimer’s first publication singled out cancer in children (children have high metabolic rates, and are perceived as more vulnerable), a substantial emphasis has been placed on abatement of EM fields in schools. Graduating students of the Occupational Health program at McGill conducted a MF

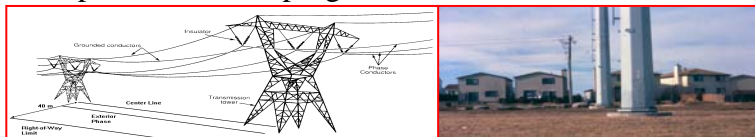

control study at the Carleton Board of Education in Ottawa in 1995. MFs were monitored with the aim of comparing MFs in schools to those in the general environment, determining what aspects of school construction influence fields in schools, the ability of buildings to shield MF applied from the outside (H.V. power lines), and in the management of strong MF sources

within the schools [Sun 1995]. In the construction of new schools, a target TLV for MFs should be 100 nT, a value which would involve only very modest supplementary costs in construction, if any.

4.6.2. Cars

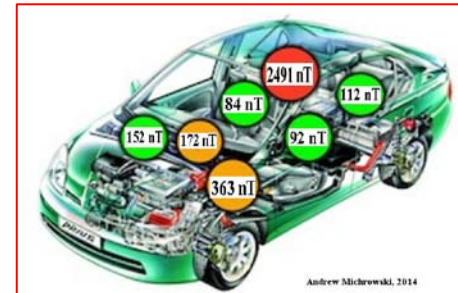

Many workers have to use cars or vehicles continuously or intermittently in their work. The general population is also a big user of vehicles that increasingly present

hybrid or full-electrical characteristics. The designers of such vehicles have not used the most appropriate safety limits to engineer their products.

In view of the evolution of car design, most electrosensitive people look for old cars, and some even care to have the steel in their tires demagnetized (rotation induces MFs sweeping up in frequency as car accelerates).

Simple car design changes are needed: use twisted pairs of wires positioned away from passengers. Use steel rather than aluminum to channel MFs away from passengers. Inverter and motor should be close together to minimize cable length. Positioning and connection configuration of batteries is important. User control over elective sources of radiation should be included in designs.

4.6.3. Portable and Laptop Computers

These popular units have not been designed to minimize MF exposures, particularly to the genitals, because of their placement [Brodic 2017]. Both the unit itself and the associated power supplies are strong sources.

4.6.4. Electric Power Workers

The ratio between average occupational and domestic exposures for *electric and MFs* is approximately **10**. The same ratio for *electrical transients* (5-20 MHz) was **180** [Héroux 1991]. A table (below) summarizing the measured MF exposures of various electrical utility occupations was obtained by Deadman [1988].

It is clear the EMF impacts do not follow a climbing dose-response to very high exposures, otherwise, certain populations would have provided compelling risk evidence.

Occupation	nT
Distribution Lineman	1450
Transmission Lineman	1310
Apparatus Electrician	344
Splicer	208
Apparatus Mechanic	118
Generating Station Operator	114

Problem 43. Why do Electromagnetic Dosimeters contain 3 magnetic coils but only 1 electric field transducer?



4.6.5. Maglev Trains

Maglev trains [Dietrich 1992], specifically the German TR07, expose passengers to strong MFs between dc and 2.5 kHz). The MFs have a complex spectrum that is highly variable in time. In the passenger

compartment, the dc MF is dominated by the geoMF (50 μ T) at head level of a standing person, with higher fields (83.5 μ T) at floor level, reflecting contributions from the vehicle. In the band between 2.5 Hz and 2 kHz, magnetic flux density ranged from approximately 10,000 nT near floor level to 2000 nT at standing head level. The MFs produced by the TR07 specifically in the power frequency range are a small part of the overall fields. The higher frequencies have a frequency range comparable to that of the distorted harmonics of power transformers.

4.6.6. Interference with Cardiac Pacemakers

Some early models of pacemakers showed unacceptable susceptibility to electromagnetic interference at ELF or higher frequencies. This susceptibility was dependent on the models used. The problems arose mostly with the advent of the more complex *demand pacemakers*. With electric sensing obtained from implanted unipolar electrodes, those units synchronize themselves with spontaneous heartbeat, in order to achieve *synchronous pacing*.

Refinements in technology have reduced the susceptibility of these pacemakers to extraneous influences, although newly designed units are occasionally showing susceptibility. When exposed to continuous interference, the units safely switch to a preset, fixed pacing stimulation (revert to the “*asynchronous*” mode). This occurs when potentials as high as 1 mV reach the unit’s amplifiers, but such events are rare because the body mostly shields the unit from high potentials. Rate of pacemaker wearer sensitivity to EM interference is about 0.5% [Ohm, 1976].

Some weapon detection gates used at airports have recently been found to use fields capable of impairing the function of pacemakers. There is therefore a need for insuring the

electromagnetic compatibility of such detection equipment with pacemakers. The ACGIH TLVs for workers wearing cardiac pacemakers should be reduced by a factor of 10 from that of normal workers. For example, the 60-Hz limit would be 100,000 nT for pacemaker wearers [ACGIH 2009].

Pacemakers have reportedly been affected by the following equipment:

- pulsed fields from domestic or industrial arc welding equipment,
- radio frequencies from high power broadcasting towers and antennas,
- radio frequencies from industrial dielectric and induction heaters,
- short-wave or radio frequency diathermy devices,
- electric fields from high voltage power lines,
- NMR devices, and
- fields from some theft or weapon detectors.

What the hygienist should do:

1. identify the possible sources of interference (type of field, frequency, power, duty cycle),
2. take measurements at the worker's position if possible,
3. reduce the fields, and
4. consult the pacemaker's manufacturer.

4.7. Standards



The Story of Procrustes

Procrustes, whose name means "he who stretches", kept a house by the side of the road where he offered hospitality to passing strangers, who were invited in for a pleasant meal and a night's rest in his very special bed. Procrustes described it as having the unique property that its length exactly matched whomsoever lay down upon it. What

Procrustes didn't volunteer was the method by which this "one-size-fits-all" was achieved. As soon as the guest lay down, Procrustes went to work upon him, stretching him on the rack if he was too short for the bed, and chopping off his legs if he was too long.

A *Procrustean Approach* forces science into a belief when it doesn't fit, just as Procrustes violently adjusted his guests to fit the bed.

The International Commission on Non-Ionizing Radiation Protection (ICNIRP) has promoted for a long time very high limits⁵ that are compatible with the desires of the power industry, and ignore health impact observations. ICNIRP has never accepted the possibility that there may be any type of cancer or other risk—to the breast, brain or blood—from EMFs or RF radiation. But many countries ignore the ICNIRP recommendations [Stam 2011].

Countries with *binding* national legislation: **Czech Republic, Estonia, Greece, Hungary, Luxembourg, Portugal and Romania. Luxembourg** also has a ministerial recommendation not to create any new living spaces in the immediate vicinity of overhead power lines (within 20 meters for 65 kilovolt lines, and 30 meters for 100 to 220 kilovolt lines). In **France** the limits only apply to new or modified installations.

Countries with *non-binding* recommendations: **Austria, Cyprus, Denmark, Finland, Ireland, Latvia, Malta, Netherlands and United Kingdom**. In some of these countries, a precautionary policy has been advised, to which electricity companies and government can voluntarily conform. **Spain** has

⁵ The International Radiation Protection Association has contributed a very strange standardization proposal to this debate by evolving safety limits applicable for *chronic* EM fields exposures which are essentially based on levels at which *acute* physiological reactions to body currents occur (for example, fibrillation currents of Chapter 1) [IRPA, 1990]. IRPA's maximum occupational exposure limit for power frequency magnetic fields is 500 μ T, the corresponding population exposure being 100 μ T. Short term occupational exposures lasting less than 2 hours per day should not exceed 5,000 μ T.

no federal legislation for exposure of the general public to EMF of 50 hertz, but some regional governments prohibit construction of new power lines near homes, schools and public spaces.

Countries with limits lower than ICNIRP, are based on the precautionary principle or due to public pressure: in Flanders, Belgium, since 2004, indoor environments cannot exceed 10% of the ICNIRP MFs in homes and buildings accessible to the public.

Bulgaria: minimal distances between homes and power lines or substations are in force depending on voltage. Emission by video screens: at a distance of 50 centimeters from video screens, the limit for the MF is 0.25% of the ICNIRP limit.

Denmark: the Danish National Board of Health recommended in 1993 not to build new homes or children's institutions close to power lines or new power lines close to homes or children's institutions. The Danish electricity sector has agreed that measures at reasonable cost to reduce the MF must be investigated if the average exposure per year is higher than 400 nT (0.4% of ICNIRP).

Italy: a 'quality goal' of 3% of the ICNIRP level applies to new construction of homes, playgrounds or schools near power lines, substations or transformers (or vice versa). An even stricter limit for MFs (0.2% of ICNIRP) was adopted in three regions before the federal law came into force.

Lithuania: for electric fields of 50 hertz a limit of 10% of the ICNIRP applies to homes and a limit of 20% of the ICNIRP level outside the home.

Netherlands: the Ministry of Infrastructure and the Environment has recommended avoiding situations with long-term stay of children in areas close to overhead high-voltage power lines with annually averaged magnetic flux density greater than 400 nT (0.4% of ICNIRP).

Poland: a limit of 20% (electric field) or 75% (MF) of the ICNIRP level applies to homes, hospitals, schools and kindergartens.

Slovenia: a limit of 10% of the ICNIRP level applies for new or modified sources near homes, schools, kindergartens, hospitals, sanatoria, playgrounds, parks, recreational areas, public buildings and buildings with a tourist destination.

Sweden: for existing situations, exposure to a magnetic flux density that differs strongly from natural background (0.1% of the ICNIRP level) must be reduced when possible at reasonable cost and with reasonable consequences.

In **Russia**, the exposure limit for electric and magnetic fields of 50 hertz is 10% of the ICNIRP level.

In **Switzerland**, a limit on MFs of 1% of the ICNIRP level applies to new installations, unless the owner can prove that the phase order has been optimized and all technically possible and economically viable measures to reduce exposure have been taken.

In the **United States**, no federal legislation is in force. In some states (Colorado, Connecticut, Hawaii, Maryland, Ohio), variations on the 'prudent avoidance' principle have been adopted. This means that exposure of the public to EMF of 60-Hertz must be limited at reasonable cost. In other states, fixed limits for the electric or MF of power lines are set, varying from 20% to 240% of the ICNIRP (Florida, Minnesota, Montana, New Jersey, New York, Oregon).

In **Canada**, there are currently no governmental health standards for ELF fields.

In the long term, the only sensible decision is that of supporting a long-term transformation to dc systems, which would emit fields barely noticeable in the environment, under most circumstances.

The most useful reference (below) for health-based limits against ELF exposures, including protection of electro-sensitive people are from the **Austrian Medical Association** [AG-EMF, 2012].

Low-Frequency Power Magnetic Fields

≥400 nT	very far above normal
100-400 nT	far above normal
20-100 nT	slightly above normal
≤20 nT	within normal limits

It is noted that “Long-term measurements should be carried out

- also and especially during the night,
- if intense and frequent field variations occur over time; in such cases, evaluation should be based on the arithmetic mean over the period of exposure.”

4.7.1. 60-Hz Electric fields

4.7.1.1. Public Exposures

Although many sources of electric fields exist in our everyday environment, by far the most intense fields can be found near high voltage transmission lines. Canada does not have a standard for 60-Hz electric field exposure although a *de facto* technical limit is already in place under high voltage lines (10 kV/m) and at the limit of the right-of-way (1 kV/m). The groups subjected to these particularly intense fields are relatively small: the utility’s maintenance personnel, and workers farming the land beneath the lines. For the rest of the population, high intensity exposures should be of short duration.

4.7.1.2. Occupational Exposure

Hydro-Québec’s network only exceeds a value of 10 kV/m within the perimeter of its own substations. Fields bordering on

10 kV/m can in fact only be found directly under the highest voltage (735 kV) transmission lines. This is the case for most electrical transmission networks worldwide.

A protection philosophy has already been in use in the USSR since 1974:

“The time of presence of workers in the zone of effects of the 750 kV line should be limited to a total duration of 1.5 hours per day, independently of whether the work is performed continuously or in segments [DSIH 1974].”

The ACGIH TLV for electric field exposure between frequencies of 0 to 100 Hz is 25 kV/m. Between 100 Hz and 30 kHz, a TLV formula is given as

$$E_{TLV} = \frac{2500}{f} \text{ kV / m}$$

where f is in Hz. At 4 kHz, the limit is 625 V/m (ACGIH 1990-1991). The logic of this formula is simple: it attempts to limit induced currents to a specific value. Since coupling to the field source will be capacitive (that is, current varies as $1/2\pi fC$), dividing the TLV by f establishes a current limit independent of frequency.

The ACGIH document claims that the recommendation is based on adverse health effects. This is certainly not true. The standard is based on a conglomerate of practical engineering considerations. In the case of electric fields, technological limits are much more accurately defined than health limits, which tend to include a large number of effects with poorly defined thresholds and consequences.

Problem 44. Describe in a few words the syndrome associated with long hours of exposure under high electric field conditions described in the early 70s by the Soviets? What countermeasures were adopted in the USSR?

Standards for Occupational Exposures in kV/m

Jurisdiction	Electric Field (kV/m)	Duration (min/day)
Czechoslovakia	15	
Germany	30	
Hungary	10	180
Poland	15	
UK	30	
USSR	25	0
	20-25	10
	5-20	(50/E - 2) x 60

4.7.2. 60-Hz Magnetic fields

4.7.2.1. Public Exposures

MRI operators have a dc field strength limit, 10,000 μT for whole body exposure, working day.

But Canada has no 60-Hz MF exposure regulation.

ICNIRP adopted limits for MFs as determined by **acute** physiological effects thresholds (magnetophosphenes), mainly because they produced the desired high values, and ignored other biological effects. The political struggle over standards is fierce: some epidemiologists would like very conservative values adopted, while utilities want the present situation legalized.

Contrary to the case of the electric field, where high intensities are almost only found near high voltage lines, powerful MF sources in the environment are not limited to a very specific class of objects: the high voltage lines are not exceptionally intense sources, and their MFs are comparable to those of distribution lines. But the exposure they contribute is sustained over time. The protests of the public relating specifically to high voltage line MFs are also related to the visual impact of

the structures, and by a desire to exclude them from residential areas, for fear of reduced property values.

But power installations near schools (child leukemia) have been under considerable scrutiny. In Boca Raton, Florida, for example, a judge ruled that an elementary school could not use a schoolyard adjacent to a transmission line.

In New York State (New York Public Service Commission), the magnetic field at the edge of the right-of-way of high voltage lines has to follow the following levels.

B field	Max	L99%	L90%	L50%	L10%
Limit	20 μT	5.5 μT	4.5 μT	3.0 μT	1.5 μT

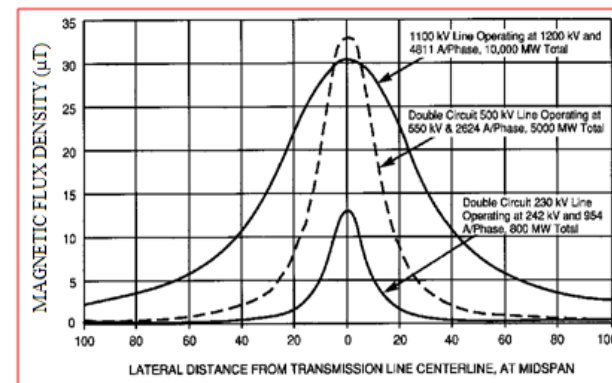

The graph shows magnetic flux density profiles at a height of 1 m and at mid-span for three different line configurations (BPA, 1985).

General population standards are under consideration at levels near 200 to 400 nT. A 200 nT standard would mean right-of-way limits for a 400 kV power line of approximately 200 m, which could be reduced to 100 m with special reconfiguration strategies. These standards would be up to 100 times more stringent than those supported by New York State and Florida, 500 stricter than the ICNIRP guidelines, and up to 2,500 times stricter than IRPA's occupational standard.

The Swedish Confederation of Professional Employees argues that MFs in new office buildings should be brought down *as much as possible*.

The EUROPAEM EMF Guideline (2016) for the prevention of EMF-related health problems and illnesses recommends a limit of 100 nT and 30 nT for sensitive populations [Belyaev 2016].

4.7.2.2. Occupational Exposure

Between **0 and 1 Hz**, the ACGIH TLV (2009) is 60,000 μT .

Between **1 Hz and 300 Hz**, the formula is

$$B_{TLV} = \frac{60}{f} \text{ mT}$$

where f is in Hz. At 60-Hz, therefore, the ceiling limit is 1000 μT . Arms and legs = 300,000 $\mu\text{T} / f$, Hands and feet = 600,000 $\mu\text{T} / f$.

For **50/60 Hz** fields specifically, the occupational exposure for an 8 hr workday is 500 μT . For pacemaker users, at 60 Hz specifically, the limit is 100 μT .

From **300 Hz to 30 kHz**, the ceiling whole or partial body exposure should not exceed 200 μT .

Here again, the formula attempts to limit induced **currents** to a specific value. Since coupling to the field source will be electromagnetic (that is, current induced is proportional to f), dividing the TLV by f establishes a current limit independent of frequency.

The ACGIH document states that the recommendation is based on adverse health effects. The truth is that it is based on **some acute** adverse health effects known a while ago; the limit is inappropriate in the context of chronic health effects (cancer).

A municipality is worried about fields in a park adjoining a high voltage line. A survey of the park shows that in a

substantial portion of the park bordering the right-of-way, the field is near 2300 nT.

Would you close the park, or move it to another location?

ACGIH limits

Calculate the ACGIH TLVs for electric and MF exposures at 1000 Hz.

$$E_{TLV} = \frac{2500}{f} \text{ kV} / m = \frac{2500}{1000} \text{ kV} / m = 2.5 \text{ kV} / m$$

$$B_{TLV} = \frac{60}{f} \text{ mT} = \frac{60}{1000} \text{ mT} = 60 \mu\text{T}$$

ELF EMF Exposure Guidelines and Reference Levels

EMF Emission Standard or Guideline	Performance Measure	Reference Level Band 1 ELF 5 Hz-2 kHz Magnetic field
CA EMF EMF Project Survey of 89 schools- 5,403 school rooms	20% of measured areas had average magnetic fields	100 nT
EMF Working Group of the Austrian Medical Association – Exposure greater than 4 hours per day	Within normal limits	20nT
	Slightly above normal limits	20-100 nT
	Above normal limits	100-400 nT
	Far above normal limits	≥400 nT
Austrian Sustainability Building Council (2009) – Total Quality Building Assessment Rating System	Excellent	100 nT
	Very good	100-200 nT
	Good	200-400 nT
	Satisfactory	≥400 nT
IEQ Project Committee Recommendation of the U.S. National Institute of Building Sciences (2006)	Preferably All occupied areas	100 nT 250 nT
TCO Criteria "Mandate A.4.2": – International sustainability standard for IT equipment (since 1992)	At 12-20' distance from equipment	200 nT
Federal Safety Guideline of Russia for Computer Workstations, including schools (2003)	At 20" distance from equipment	≤250 nT
International Agency for the Research on Cancer/WHO (2002)	Possibly carcinogenic Group 2B	>300-400 nT Increased childhood leukemia risk

Austrian Sustainability Building Council (2009) – Total Quality Building Assessment Rating System

4.8. Control Measures

NIOSH recommends informing workers and employers about possible hazards of magnetic fields, increasing workers' distance from EMF sources, using low-EMF designs wherever possible (e.g., for layout of office power supplies), and reducing EMF exposure times (NIBS 2005).

Most recent scientific evaluations of ELF health effects [ANSES, 2018] recommend protection for sensitive populations: children and sick, pregnant women, specifically that no school or hospital be built near a power line.

In premature births, exposition from incubators is a concern. Likely strong sources of ELF MFs are utility equipment (transmission and distribution lines, substations, transformers, switching equipment and electrical cables), the wires hidden in buildings (either commercial or private), and appliances (fluorescents and ballasts, pencil sharpeners, motors, aquarium pumps, office equipment, soda machines, sewing machines, shop machines, mixers, microwave ovens).

In the absence of national or provincial norms considering the chronic health effects of MFs, a number of corporations have taken local administrative action.

There is little reason at the moment to seek **electric field** abatement, since there is no epidemiological evidence supporting substantial health effects of electric fields. Unfortunately, while electric fields can be cheaply and effectively shielded, MFs are expensive and difficult to shield. The control measures for **MFs** follow the general rules of hygiene. Try to control the source. If impossible, attempt a physical separation between source and subject. And, last, attempt to shield the subject or source. Complete software is already commercialized for the modeling of emissions from High Voltage power lines. See the video:

Electromagnetism/EM Videos/23 3D EMF Calculator.mp4

4.8.1. Source Control for Power Utilities

In practice, the first rule of MF abatement in electrical wiring is to **keep the neutral returns as close as possible to the power feeds**. Infractions to electrical wiring code within a house, for example, are very likely to result in increased MF exposures due to this mechanism [Adams 2004].

Currents stray from the utility distribution system by connection techniques such as the multigrounded neutral system and others, that have favored cost cutting over electrical safety, but have also increased substantially population exposures to MFs. Circuits in which the earth or an equivalent conducting body is utilized to complete the circuit allows the current circulation back to its current source through structures

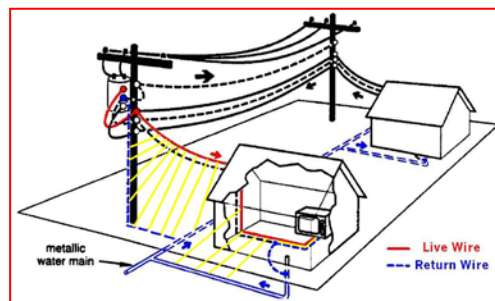

that are not only unpredictable, but also include private grounding connections. These techniques use the grounding of domestic customers to buttress deficient

systems, resulting in uncontrolled ground currents both in normal exploitation, and during transients, such as lightning strokes. Utilities can improve phase balancing for transmission and distribution lines, such that little current needs to return through the ground.

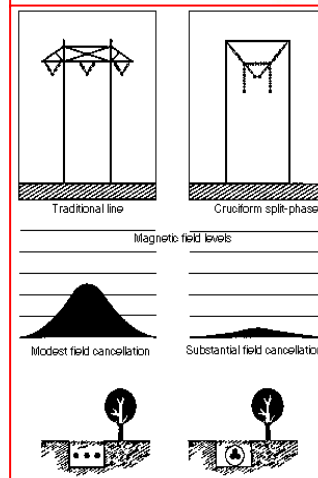

The electric industry could explore low-field transmission line configurations, new residential wiring and grounding methods, and new concepts for shielding personnel from fields in the workplace [Zipse 2003].

Low-field transmission line systems may reconfigure the existing phase conductors, use more than one conductor per phase (sharing the total current), called “split phase”, or use 6 to 12-phase configurations.

In the case of **distribution lines**, one low-field configuration is the “Hendrix Aerial Cable” where conductors are centered on a diamond shape, 20 cm apart.

Undergrounding, because it brings the three phases of a transmission line close together, reduces fields considerably.

4.8.2. Source Control for Schools and Home

For example, in an electrical box in a home, it is important to



control neutral returns. If currents do not return to the electrical box following the appropriate wire, magnetic fields in the building will be considerably augmented. Such leakage currents can be detected with clip-on transformers circling the outgoing wires at the electrical box. In case where the fault is

downstream in a 3-way switch circuit, a magnetic field measurement will detect the fault.

Some suggestions for Safe Buildings require low MFs that are near the average levels found in homes. The Planetary Association for Clean Energy recommends levels below 65 nT and mentions that health concerns occur at 100 nT [Safe Housing Ottawa, 2009].

The following precautions have been suggested for schools:

- Fix Improperly wired subpanels (neutral-to-ground bond);
- Fix Incorrect three-way switch wiring;
- Fix Incorrect wiring of switched outlet circuits;
- Avoid neutrals from separate branch circuits that are connected anywhere beyond the panel of origin for the circuits;
- Avoid neutral-ground shorts (intentional or inadvertent) anywhere in the system.

It is possible, even completely unwittingly, to build schools respecting levels of 100 nT, and with the capability of attenuating MFs originating outside the school. If the “hot spots” due to various internal electrical devices can also be controlled, low MF environments can indeed be provided at very low cost.

“The correctness of the wiring shall be checked in each room and the ELF MF exposure measured levels (true RMS) comply with 100 nT in new construction and 200 nT in existing school modernizations.” Collaborative for High Performance Schools

The US National Electrical Code requires that electricians ground the electrical neutral wire as it enters a residence by connection to a **metal pipe** or to a metal spike driven into the soil. This is a safety feature aimed at making sure that

individuals who touch elements of both the plumbing and electrical system frames receive no shock. Because of this connection, however, some of the current that should go back through the electrical neutral is actually carried by the pipes to the utility's ground connection at the foot of the electrical poles, increasing MFs levels. The ground currents flowing back to power sources must be minimized by reducing the role of water pipes as a ground return. To achieve this, a current-interrupting plastic water pipe segment (30 cm) in the water main of a building [Maurer 1993] can be inserted, but at least 3 m from the entrance point to the building (to maintain shock safety grounding).

4.8.2.1. Wire Twisting

In some cases, it may be appropriate to use twisted conductors rather than parallel pairs. It is easy to obtain reductions of irradiated field by a factor of 10 by such twisting. Best residential wiring and grounding methods aim at keeping return currents close to power currents, and use twisting of conductor pairs to obtain further reductions [H eroux 1990]. At least two large manufacturers of electric blankets have altered their designs based on these principles.

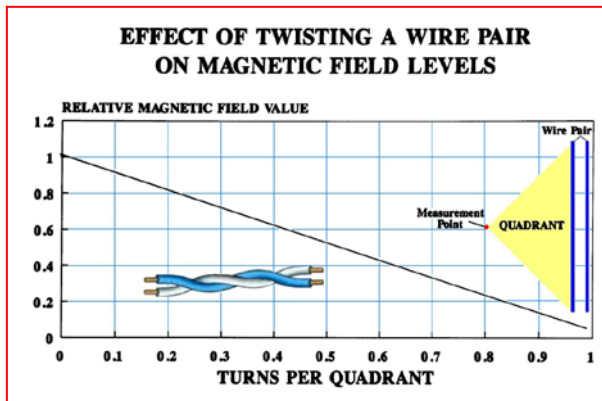

4.8.2.2. Co-Axial Cable

If one is willing to accept some wiring cost increase, **coaxial cable** can essentially eliminate radiated MFs within a respectable bandwidth.

Ranking by Best Atten. Perf.	Ranking by Best Shielding Perf.	Ranking by Best Physical Toughness	Ranking by Flexibility	Outer Conductor Style
1	1 >100 dB	4	3	 Wrapped Foil + Woven Round Braid
2	2 >90 dB	1	5	 Woven Flat Braid + Wrapped Foil + Woven Round Braid
3	3 >80 dB	2	4	 Woven Flat Braid + Woven Round Braid
4	4 >65 dB	3	2	 Two Woven Round Braids
5	5 >40 dB	5	1	 One Single Woven Round Braid

4.8.2.3. Other Methods

Unshielded motors and transformers (no steel enclosure) are light and cheap, but are strong sources of MFs, and wasteful of energy.

4.8.3. Increasing Distance

The fields from **transformers, switching equipment** and other sources can be reduced best by distance (use of trees, bushes and fences outside, marking of areas with paint or furniture arrangement, inside). Remember that walls generally contribute no attenuation for MFs.

The utility Stockholm Energi in Sweden has in at least one instance **moved** a transmission line in response to health concerns.

Long **fluorescent lights** combined with low ceiling heights tend to create large MF exposures.

4.8.4. Shielding

Shielding of MFs with conductive or magnetic envelopes is generally an expensive measure. The effectiveness of various thicknesses of materials such as iron, aluminum and copper at various frequencies are documented in detail [Hemming 1992].

In the case of tools which contain magnetic sources (coils), and need the mechanical integrity typical of metal, there is an obvious opportunity to optimize a metallic casing for many types of equipment. As well, a metallic core can be imbedded in plastic casings provided for the purpose of double insulation.

In a smelter, workers stand on a platform near an induction furnace to control the pouring of metal. Dosimetric

measurements on workers show that both the all-day and pouring operation field levels are appreciable (nT):

	All-Day Mean	Pouring Metal
A	1810	7170
B	5350	12300
C	2070	1430
D	1820	4240

Simple measures marking the hot spots around the furnace with visible and lasting markings yield a reduction in exposures ranging from 1.7 to 5.

4.8.5. Field Cancellation

In order to protect a volume of space from undesirable MFs, it is possible to attenuate exposure by introducing an artificial opposing field. In order to apply the field to the volume to be protected, it is necessary to build large wire coil structures as shown in red-blue-green in the figure. Cancellation is not perfect, because the counterpoise field has its own spatial

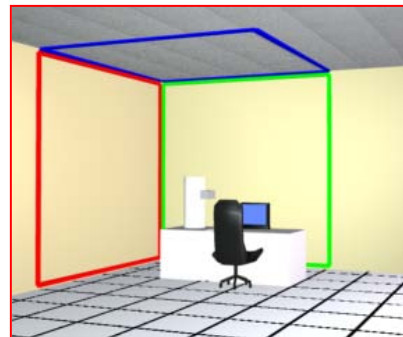

variation, which compensates only approximately the original field. In practice, good compensation can only be achieved for a relatively small volume. In most situations, if it is worthwhile to construct such a structure, it is also a good idea to make the

injected field adaptive, so that field fluctuations in the source can be automatically matched by the counterpoise.

A sensor placed in the volume to be protected relays information to an electronic system (above) which is designed to minimize the resulting field in real-time.

4.8.6. Practical Situations

According to Riley [1995], who conducted extensive surveys on MF mitigation, many high levels are connected to electrical code violations, in grounding especially. Essentially, neutral conductors are being grounded in various points within a building, rather than being all brought to a single neutral point in the main electrical box. This causes a separation between power feed and power return, enhancing the fields.

Most elevated field situations are caused by such violations, followed by power lines, among which the distribution primaries are the main culprits.

4.8.7. Survey Procedures



Generally, surveys can be *Emission*, *Exposure* or *Area* measurements.

An *Emission* survey documents the fields emitted by a particular device:

fields vs distance from the device, taking into account the function and characteristics of the device.

An *Exposure* survey attempts to document human exposure in a given environment, as a dosimeter would do automatically,

but manually documenting readings as connected to specific placements or activities.

An *Area* survey documents the fields within a given space. An *Area* survey can be *device oriented* or *occupant oriented*, depending on whether it concentrates its measurements on expected high intensity sources, or whether it attempts to cover the spaces most often occupied ("where people are").

A survey report includes:

1. A drawing of the property (floor diagram) and of electrical sources (a wiring diagram may be available for industrial sites).

The choice and pattern of measurement points is according to the aims of the survey (population to be protected, type and use of building). Areas of particular concern may be emphasized (areas occupied by a child), but the impact of any sampling bias in the measurements must be taken into account in the final evaluation.

2. MF measurements of areas and selected equipment.

The time-of-day and year of the survey must be noted to take into account diurnal and seasonal variations in general electrical consumption, and from distribution lines and variations in facility use.

If possible, survey first the property while its own electrical supply is turned off at the main breaker switch. This allows the surveyor to distinguish between field contributions emanating outside the site, as opposed to within it.

After obtaining reasonable amounts of data, brief analysis (sometimes with analysis of peak, mean and standard deviation) should allow the surveyor to identify specific sources and to classify them as movable (ex. table radio) or unmovable (ex.

electrical heating board), an information of practical consequence for mitigation.

3. Identification of locations with unusually large fields, specifically suspected grounding and plumbing current problems, as well as electrical code violations (neutral to ground shorts, parallel neutrals).

Most large fields are due to high power devices. At times, alternate device types may provide remediation, while in other cases, only insuring distance of the exposed to the source will prove effective mitigation.

In industrial sites, a profitable field management method is often to assign highly exposed rooms to uses that minimize human presence.

4. If the MF levels are significant, then recommendations should be made:
 - ✚ correcting electrical code violations (grounding and wire-loops),
 - ✚ use of distance by re-localization of facilities or people,
 - ✚ insulating pipe segments on water service lines to minimize grounding currents through plumbing,
 - ✚ magnetic shielding and MF cancellation techniques.

Some clients will also request risk assessment comments. This is particularly sensitive if the survey was triggered as a result of an illness in the workplace.

4.8.8. DC Systems would Eliminate Risks

The Time-Weighted-Average ELF MF values relevant to the present EM environment are mostly 0 to 1000 nT domestically, and perhaps up to 5000 nT in most industries. It is clear that

such values are much smaller than the static field of the Earth (~50 μ T). Therefore, it is expected that a wholly dc power system would emit dc fields of values less than 10% of the field of the Earth, even without a specific effort to improve field cancellations, and this variation is comparable to natural variations at the Earth's surface. The proximity of metals, particularly ferro-magnetic ones (in building and bed structures, for example), produces significant perturbations of the Earth's MF, which means that there have been such variations for a long time in our environment. Also, as we rotate, the direction of the Earth's field relative to our body changes. Since we are obviously adapted to this, significant biological effects are unlikely from a dc power system. Therefore, all costs of ac MF mitigation would vanish in a transition to dc power.

4.9. Risk Assessment

4.9.1. Risk Quantification

A somewhat arbitrary lowest level of risk to be considered in policy decisions (below which, risks are "acceptable") is **10^{-6} per lifetime**. A risk scale based on the simple **\log_{10} of the risk per lifetime** can be established: "- 6" is the smallest risk limit that the EPA considers, while an extremely high risk, such as that of dying in your lifetime from any cause, would rate as 0. The scale can be detailed as follows. The number of childhood leukemia cases added by ELF MF exposures depends on the exposed population size, the baseline unexposed leukemia rate, and the relative risk associated with a given MF exposure.

Considering that the effect of MFs would be small at 10 nT, that epidemiology shows a risk of 2.7 at 200 nT (Feychting), and that the median exposure in homes is about 100 nT, a reasonable figure would be that MF exposures double the number of leukemia cases. With a childhood leukemia incidence of 50 per 1,000,000 per year, with half due to MF

INDEXES FOR SELECTED CAUSES OF DEATH

Cause of Death	Lifetime Risk Index
Death from any cause	0
Spanish flu epidemic, most exposed groups	- 0.6
Cardiovascular disease	- 0.6
All cancers	-0.85
Motor vehicle accident	- 2
Murder	- 2.5
Fire	- 2.9
Firearm accident	- 3.4
Electrocution	- 3.7
Asteroid/Comet impact	- 4.3
Passenger aircraft crash	- 4.3
Flood	- 4.4
Tornado	- 4.8
Venomous bite or sting	- 5
EPA lowest risk	- 6
Fireworks accident	- 6
Food poisoning by botulism	- 6.4
Drinking water with EPA limit of trichloroethylene	- 7

exposures, the risk is sizable, and should be controlled, even if only childhood leukemia risk is taken into account.

The risk would be even more important if other cancers and diseases were also magnified by exposure to ELF MFs [Li and Héroux 2012, 2013, 2019].

4.9.2. Prudent Avoidance

The most difficult element that the hygienist has to deal with is the persistence of relatively high exposure standards, together with the recent epidemiological evidence dealing with cancer. A risk assessment specialist stated [Morgan 1993] that “If anyone should be faulted for the poor quality of responses to risk, it is probably not the public, but rather risk managers in government and industry.” Corporations and governments have

often shown poor performance in dealing with emerging risks associated with commercial products (ie, global warming).

It is a shock for the producer of any substance or device to learn of new deleterious health effects. In the most extreme situations, the stages of resolution closely parallel those of a dying individual: shock and denial, anger, bargaining, fear and anxiety, depression and acceptance.⁶

While the “emerging risks” are emerging, the science documenting them can seem unreliable. Often, the laboratory techniques necessary to document “emerging risks” are being developed as the risks are being recognized. Epidemiological studies become increasingly sensitive only as study designs are refined to address a specific risk component.

In this uncertain situation, Morgan has promoted the concept of “Prudent Avoidance” to describe his recommendations towards EMF health risks. In the presence of uncertainty, protection should be provided when possible. “Prudent Avoidance” simply means that in the face of a risk of uncertain magnitude, measures that are not too onerous should be taken to mitigate the risk. In practice, then, in the absence of a “clean slate” solution, all simple and economical means of avoiding ELF field exposures are acceptable, as long as they do not involve unduly large costs or large time investments by the people to be protected.

Landmark values, such as the feasibility of reducing fields to 50 nT or less in school buildings, as well as the exposure threshold of 3100 nT-year for occupational exposures, can be used as guides.

⁶ Managers of the U.S. tobacco industry apparently felt completely at ease in April 1994 while testifying to the U.S. Congress that the link between smoking and lung cancer was merely a statistical correlation, and that smoking was, in fact, a non-addictive habit.

The hygienist should be aware that many organizations frequently adapt to new situations with reactionary attitudes: spotlighting older assessments which concluded to safety of products, casting doubts on the new scientific or epidemiological evidence, and generally developing an internal culture which tends to discredit the evidence of risks.

Some organizations may try to evade responsibilities which would involve increased costs and, consequently, reduced profits. A frequent strategy in such organizations is to appoint risk managers who go slowly in addressing the problems. In the end, the basic beliefs of the people involved in this process play an important role in the outcome because in management, there are many opportunities to re-order priorities, especially when problems are chronic, complicated and costly.

The flip side of this process is that there are few things that the public is more perceptive to than self-interest. Consequently, there is a blanket suspicion of the actions of corporations when it comes to internally generated safety assessments.

The role of government is, of course, to impose safety and exposure limits. One of the most difficult decisions is how much to restrict products when there is not yet definitive evidence of danger, but when disturbing data is available. This role has often been played by the courts in the US. It should be realized that approved safety limits do not necessarily shield from responsibility. In spite of legal protection afforded by the various standards, a key legal case was settled in April 1993 involving six-year old Mallory Zuidema and the San Diego Gas and Electric Co. Her rare case of kidney cancer was attributed to prenatal exposure to EMF emitted by power lines.

4.10. Summary

Power systems radiate electric and MFs, nEMFs, which are elements added to the electromagnetic environment of the body. Most of the attention has been concentrated on MFs, with typical environmental values at around 100 nT. Dosimeters and field meters are available for recognition of the EM environment. Effects on water, melatonin, neuro-hormones, protein synthesis, enzymes, ROS, ATPS, and calcium efflux have been documented in the laboratory. Epidemiological evidence has been gathered on risks related to childhood and adult leukemia, brain cancer, while others, such as breast cancer and Alzheimer's disease, are emerging [Jalilian 2017].

Standards of MFs do not address the present health concerns because of the unacceptable situation that would be created if fields had to be severely controlled overnight, particularly in industry. Industry has slowly moved to evaluate mitigation techniques that could be applied with some success to power distribution. Perhaps a move to a dc network is the ultimate solution to the problem.

4.11. Appendix: a New DC Power Grid

4.11.1. Statement

The time seems right to start the replacement of the electrical utility ac power system by a dc system for transmission, distribution and consumption of electrical power.

The present ac system has long had many fundamental problems. Over long distances, cables had to overcome their capacitance, while overhead lines had to overcome their inductance, making power transmission inefficient or more expensive.

Another problem is that in an ac system, generators and electrical machines must be synchronized for power transfer to be effective. This is the network *stability* problem which makes it difficult to re-power electrical grids after a shutdown, and makes interconnection of large power networks difficult.

Another serious problem is that ac MFs have been linked to cancer, particularly leukemia in children, which creates difficult implantation problems for new power corridors. Epidemiological data gives opponents of power line projects powerful arguments to stop them.

Our own research at the Royal Victoria Hospital in Montreal has recently produced data supporting the role of extra-low-frequency MFs in enhancing leukemia, as well as other cancers (<http://www.invitroplus.mcgill.ca/>). The effect is based on a disruption of metabolism by MFs. We have also provided a physical mechanism to explain the effect, thereby removing the oldest and most powerful argument aimed at discrediting epidemiological observations on the biological impacts of MFs.

ELF MFs are biologically active, and we believe that it is not prudent to expose the general population to such fields. For years, the electrical industry argued that ionizing action on molecules was necessary for any biological action, while in fact, very low field levels can act directly on electrical charges (electrons and

protons) freed in enzymatic reactions.

We argue in the present article that the electrical industry can avoid a protracted implication in MF health questions if it accelerates its implementation of a dc grid. If the past is a guide, the scientific community takes prodigious amounts of time to reach unanimity on similar complex questions. For example, 21 years elapsed between the initial observation by Wertheimer linking leukemia in children to cancer in 1979, and confirmation that the effect was genuine by the International Agency for Research on Cancer in 2001

(<http://monographs.iarc.fr/ENG/Monographs/vol80/mono80.pdf>). Science is rich in diversity, but poor in unanimity. Uncertainty on this question is deleterious to society and to the electrical industry.

The electrical engineering community can act decisively such that it will remove the health risks of ac fields, while accelerating its own technical developments and modernization of the electrical grid.

Elimination of extra-low-frequency MFs to levels of 10 or 20 nT (such as recommended by the Austrian Medical Association) to avoid biological action is impractical for wide-scale, and in particular, industrial applications. Ac high voltage lines would need right-of-ways of 2 km to reduce fields to safe values. The power distribution systems produce MFs of hundreds of nT, comparable to the contribution of home wiring and appliances. Although coaxial conductors could be used to reduce MF emissions, the alternative of distributing and consuming electricity as dc is far more practical. Already, parts of the electrical industry have been gearing up for a change to dc, based on a simple motive of energy conservation.

4.11.2. AC and DC Magnetic Fields in the Environment

Pre-industrial ac MFs were vanishingly small compared to the ac MFs in the present environment, and even more compared to the 1000 nT typically found at the border of a transmission line. If the

line was converted to dc, a similar static field would only rate as 1/50th of the Earth's MF.

All living systems have evolved to tolerate static MF variations. Rotation of the human body on the Earth's surface changes the direction of the MF within tissues. Proximity to any ferromagnetic object, such as a car, perturbs static MFs. For example, the static field in my laboratory is about 37,000 nT, but in close proximity to a sink, the field rises by a factor of 4. The static MF impact of electrical power would then be in the same league as the Earth's, comparable to magnetic perturbations that have been with us at least since the iron age.

4.11.3. Advantages to the Power Industry

4.11.3.1. Transformers to Power Electronics

The power industry adopted ac because transformers were an efficient way of altering voltage levels without large energy losses, which could not at that time be done for dc. Transformers made transmission of electrical power possible over long distances. But there are many practical problems with transformers. They are bulky and heavy, expensive to make, contain flammable materials, and are non-modular. Delivery lead times for very high power units are a year or more. Like the internal combustion engine, transformers have served us very well, but should be mostly retired.

Since the development of semiconductors such as large-power thyristors, integrated gate-commutated thyristors, MOS-controlled thyristors and insulated-gate bipolar transistors, it has become possible to alter dc voltage levels with an energy efficiency that rivals that achieved by transformers. The semi-conductors act as switches that charge groups of capacitors in series, and discharge them in parallel, to reduce voltages. Output voltage can be fine-tuned by altering the charging time. Semi-conductor power electronics also present a supplementary opportunity to manage the magnitude and direction of power flow.

Power dc converters can be assembled from components and

modular circuitry, similar to a computer. This modularity means that power electronic systems can be assembled comparatively rapidly in many configurations from components or modules, and can be much more easily repaired, reducing downtime following failures. By comparison, transformers must be assembled as a single block surrounded by a steel oil reservoir, which makes them very difficult to repair.

4.11.3.2. DC for Long Transmission Lines

The electrical industry, to serve economic expansion, has been looking at alternatives to ac power to strengthen its power grid. Most of the popular techniques are based on dc power, which offers a low environmental impact both electromagnetically (dc MF vs ac MF), and visually (more compact structures).

Electrical utilities are currently managing an unprecedented growth in dc installations worldwide. Back-to-back dc links have allowed the connection of large asynchronous ac networks, while avoiding stability problems.

High-voltage direct current has been used for the past 40 years to transmit bulk power over long distances, to feed power to islands, and across north-south (climate) and East-West (time-zone) boundaries, to attenuate crests in power demand. In 2008, 8% of electrical energy was exchanged across borders, but this is expected to increase sharply in the future. Europe needs wind and hydro-electric power from the north, and solar energy from North Africa, over long dc lines and cables. A dc grid is, so to speak, *ready for export*.

According to a February 2011 article in IEEE Spectrum, up-front costs are about equal between ac and dc, but dc systems' simpler components provide cheaper, more reliable power.

The transition to dc power is possible without compromising present structures. Ac transmission corridors can integrate dc lines, so-called *hybrid transmission* corridors.

An ac line, when re-configured to dc with minimal investments, can accommodate much more power flow. To understand why

this is so, one considers that a dc power line (1) is always working at its maximum voltage (a gain of 30%), (2) has no skin effect (the tendency of ac current to form a doughnut on the section of conductors), and (3) does not need reactance compensation.

In an ac-to-dc line conversion, a tripole dc configuration uses all three ac phases, without the need for earth return. Conversion from ac to bipolar dc is simple, and a well-known solution.

Monopole and bipole convertors are used in parallel, such that the

full thermal rating of all three ac phases is used for dc. This can be accomplished without requiring the use of any unproven equipment. During the conversion, it is even possible to keep an ac line in operation, while dc-rated insulators are installed.

As transmission capacity requirements increase, dc transmission is becoming steadily more popular, as dc is the only effective means of increasing power flow on a corridor originally built for ac transmission.

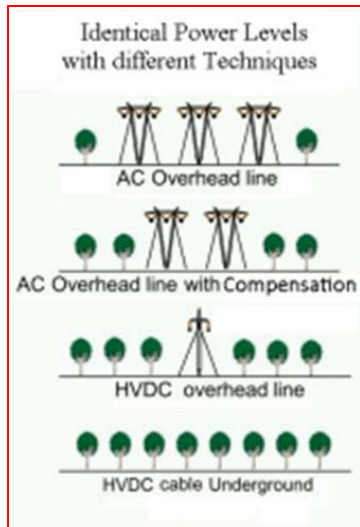

There is, of course, one aspect where ac power is superior: activation of a switch on an ac circuit benefits from periodic passage of current to zero. On a dc system, the switch has to absorb the arc's full energy to interrupt the current. This is not a problem for relatively small voltages, but utility high voltage dc circuit breakers are difficult to build, because a system must be included to force current to zero. In November 2012, the company Asea Brown Boveri announced development of the world's first high voltage dc circuit breaker. Until such breakers become inexpensive, it will remain economical to rely on the present ac

high voltage grid components for interruption. But industry is ripe to meet the challenge, with most companies at the ready to fill dc systems demands.

dc will also increase the use of underground cables. The cost for an underground cable has traditionally been ten times the cost of an overhead line. However, it is claimed that the cost of a dc cable approaches the cost of an overhead line, if all factors are taken into account. A dc cable has an environmental impact of 64.5 kg of CO₂-equivalents per meter, while the ac overhead line has an impact of 365.4 kg of CO₂-equivalents per meter. In other words, the material used in the dc cable has only 17.6 percent of the environmental impact of the ac line. The right-of-way for a buried cable can be 4 m, as opposed to 60 m for an overhead power line: a sidewalk, as compared to an autoroute (see figure).

Although the traditional practice has been to use dc circuits for bulk transport of large amounts of power between distant locations, new developments have extended the economical use of dc to a few tens of megawatts (about 1000 houses), and lines as short as 40 km. There are already many commercial systems available: HVDC Light (ABB Group), HVDC PLUS (Siemens) and HVDC MaxSine (Alstom).

dc facilitates energy exchanges not only between high level networks, but also between all types of sources, as only voltage level needs to be matched, rather than voltage *and* phase for ac. The magnitude and direction of dc power flow can be directly controlled, inciting many power system operators to contemplate wider use of dc for its stability and simplicity benefits alone. dc improves compatibility of electrical networks with a number of smaller green sources such as wind and solar energies. Tomorrow's power system may still depend on large central-station generation, but it should also integrate renewable energy generation, both at the commercial and private levels.

Energy storage is essential for critical applications, such as airports, broadcasting, hospitals, financial services, data and

telecommunications centers, and many finely tuned industrial processes. These businesses maintain generators at the ready when power quality and reliability are compromised. Such backup systems would be more economical under dc. More energy storage would be deployed by electric utilities, commercial operations and end users, due to the lower cost of energy storage systems. Present commercial and industrial systems can supply power for up to 8 hours at 75% efficiency, and maintain performance through more than 5000 charge-discharge cycles. Residential versions typically involve two hour durations at 75% efficiency.

Utilities could implement in their networks fast active power controllers using power electronics that include bidirectional dc/dc converters for the enhancement of stability based on fast energy storage systems such as Superconducting Magnets, Super capacitors and Flywheels.

Rather than utilities shutting off systems within an individual's home using *smart meters*, it may be preferable to offer consumers a means of avoiding crest-power costs and of contributing power to the grid through their own Home Energy Management system, already being marketed by Comcast, AT&T and ADT. In this scheme, you may be able to re-sell to the utility electrical power stored in your home batteries or electric vehicle at a profit at certain times, thereby increasing consumer participation. Homes with a battery or car-based power autonomy could support the electrical network during crest periods, and widespread deployment of such systems would considerably simplify routine maintenance operations in the distribution system by allowing many hours of de-energized maintenance without inconvenience to consumers.

4.11.3.3. DC for Distribution

Conventional transformers have poor energy efficiency at partial loads, use liquid dielectrics that can result in costly spill cleanups,

and provide only one function: stepping voltage. They do not, in particular, provide real-time voltage regulation.

Models of different ratings are required to cover a range of powers, do not allow supply of three-phase power from a single-phase circuit, and are not parts-wise repairable.

By contrast, power electronics equivalents eliminate the majority of the inductance and, along with it, all of the oil used as coolant, resulting in a substantial reduction in losses. They also offer a great deal more flexibility in voltage control.

The Electric Power Research Institute in the US has developed a first-generation power-electronic replacement of conventional distribution transformers. It includes a bi-directional power interface that provides direct integration of photovoltaic systems, storage systems, and electric vehicle charging. It provides an architecture that allows the operation of reliable local energy networks. Deployment is expected to grow rapidly, from 10,000 25-kW units in 2015 to 1 million in 2030.

4.11.3.4. DC for Consumption

Most electrical devices are native dc devices. Lighting, heating and computing use dc. Large motors should (and already are) dc powered, and smaller ac motors can be economically upgraded to variable-speed power motors with increased effectiveness by power inverters. dc promises simpler equipment and significant energy savings. After more than a dozen beta installations worldwide, dc wiring is going commercial, as manufacturers have already started selling the first products challenging ac's 120-year dominance.

Standardization efforts are set to accelerate dc's commercial adoption. The EMerge Alliance (<http://www.emergealliance.org/>), representing more than 100 manufacturers of power equipment, electronics, and building components, certified the first commercial products meeting its standard for 24-volt dc circuits, aimed initially at overhead lighting systems. LED lights running on 24-V dc lines will require up to 15 percent less energy than the

same lights running on fixture-level rectifiers. 24 V is for short distances (10 m), and below the shock hazard level, reducing human risks, so a second 380 V level is planned to cover entire buildings. Even the telecommunications industry (European Telecommunications Standards Institute, ETSI) is expected to join in, issuing draft standards for 380-V dc wiring for building-wide power distribution, thus making it potentially a world standard.

4.11.3.5. DC for Computing

Telecommunications firms and data centers are likely to adopt 380-V dc immediately. The energy costs of mammoth data processing facilities are steep, requiring their own power plants and cooling facilities. In 2010, Google's servers alone used 2.3 million megawatt-hours, comparable to 200,000 homes. Today, data centers take 480-V ac from the grid, and convert it to dc to charge the battery of an uninterruptible power supply. The secure dc is then converted back to ac and transformed to 208-V ac for distribution, only to be rectified back to 380-V dc by the first stage of each server's power supply, to charge power-smoothing capacitors. Dc distribution offers a comparatively simple scheme where 380-V dc can both charge the uninterruptible power supply and supply the servers. A data center in Charlotte, North Carolina, measured a 15 percent reduction in power consumption in a test of a 380-V dc distribution system. Net energy savings could be twice that, once the cooler-running equipment's reduced air-conditioning is factored in. Distributing dc enables replacement of ac-dc converters within individual devices with a smaller number of larger, more efficient converters. In effect, power losses are likely to be reduced by a factor of 5. The advantage of dc in feeding the population explosion of computers worldwide and of the Internet means that whatever improvements are made in ac power systems, dc will always remain superior, a cheaper, more reliable power source. A

domestic electrical network based on co-axial cable would allow a computer to connect into a network without any problems of electromagnetic compatibility (no emissions), with a single wire acting both as a data and a power conduit.

4.11.3.6. Implementation of the New DC Grid

Given the natural tendency of industries to maintain habits, it is impressive that the dc movement is already spontaneously gaining credibility. It seems probable that communities that anticipate the change, and invest in future, as opposed to obsolete techniques, will ultimately gain a strategic advantage. In view of the long lifetime of electrical infrastructures, we propose that for reasons of public health, energy conservation (a global energy consumption reduction of 20%) and strategic industrial positioning, we impose a moratorium on the construction of any new ac systems (at any voltage), and instead direct utilities to invest in a new dc grid. This solution is extremely effective in reducing extra-low-frequency MF exposures, and would lead most electrical devices to slim down in size and weight by losing the weighty transformers that have served us until now. The electrical grid would be more effective, reliable and dependable, to the benefit of all.

4.12. Bibliography

- Aarholt 1981** et al. Effects of Low-Frequency Magnetic Fields on Bacterial Growth Rate. *Phys Med Biol* 26(4):613-621.
- Aaron 1999** et al. Power frequency fields promote cell differentiation coincident with an increase in transforming growth factor- β expression. *Bioelectromagnetics* 20(August):453.
- Adams 2004 et al.** Importance of Addressing National Electrical Code Violations that result in Unusual Exposure to 60-Hz Magnetic Fields. *Bioelectromagnetics* 25:102-106.
- AG-EMF 2012.** Guideline of the Austrian Medical Association for the diagnosis and treatment of EMF related health problems and illnesses (EMF syndrome).
- Ahuja 1997** et al. Comet assay to evaluate DNA damage caused by magnetic fields. Proceedings of the International Conference on Electromagnetic Interference and Compatibility, December, Hyderabad, India, pp. 273-276.
- Ahuja 1999** et al. In vitro effects of low-level, low-frequency electromagnetic fields on DNA damage in human leucocytes by comet assay. *Indian J Biochem Biophys* 36:318-322.

- Albert 1984** E et al. Bioelectromagnetics Society, 6th Electron Microscopic Observations On Rat Cerebellum And Hippocampus After Exposure To 60-Hz Electric Fields (meeting abstract). Annual Meeting, 15-19 July, Atlanta, GA, p. 4.
- Anderson 1982** et al. Pineal Gland Response In Rats Exposed To 60-Hz Electric Fields (meeting abstract). Bioelectromagnetics Society, 4th Annual Meeting, June 28 - July 2, 1982, Los Angeles, CA, p. 15.
- Anderson 1989**. Interaction of Elf Electric and Magnetic Fields with Neural and Neuroendocrine Systems. Extremely Low Frequency Electromagnetic Fields: The Question of Cancer. B. W. Wilson, R. G. Stevens, L. E. Anderson, eds., Columbus, OH: Battelle Press, p. 139-157.
- ANSES 2018**. Hypersensibilité électromagnétique ou intolérance environnementale idiopathique attribuée aux champs électromagnétiques (382 pages). <https://www.anses.fr/fr/system/files/AP2011SA0150Ra.pdf>
- Asanova 1966 et al.** The Health Status of People Working in the Electric Field of Open 400-500 kV Switching Structures. Russian. Gig Tr Prof Zabol 10(5):50-52.
- Bagkos 2014 et al.** A new model for mitochondrial membrane potential production and storage. Med. Hypotheses 2014, 83, 175–181.
- Bagkos 2015 et al.** Mitochondrial emitted electromagnetic signals mediate retrograde signaling. Med. Hypotheses 2015, 85, 810–818.
- Barnes 1986** FS. Extremely Low Frequency (ELF) and Very Low Frequency Electric Fields: Rectification, Frequency Sensitivity, Noise, and Related Phenomena. Handbook of Biological Effects of Electromagnetic Fields, Polk, C.; Postow, E., eds. Boca Raton, FL: CRC Press, Inc.; 121-138.
- Bastuji-Garin 1990 et al.** Acute leukemia in workers exposed to EMF. Eur J Cancer 26:1119-20.
- Bawin 1975** SM, Adey WR. Effects of Weak Low Frequency Electric Fields on Calcium Efflux from Isolated Chick and Cat Brain (meeting abstract). International Union of Radio Science, 1975 Annual Meeting, 20-23 Oct. 1975, Univ. of Colorado, Boulder, CO. USNC/URSI (Washington, DC): 267.
- Belliemi 2012 et al.** Is newborn melatonin production influenced by magnetic fields produced by incubators? Early Human Development 88 (2012) 707–710. doi:10.1016/j.earlhumdev.2012.02.015.
- Belyaev 2016 et al.** EUROPAEM EMF Guideline 2016 for the prevention, diagnosis and treatment of EMF-related health problems and illnesses. Rev Environ Health 2016, DOI 10.1515/reveh-2016-0011.
- Beniashvili 1991 et al.** Low-Frequency Electromagnetic Radiation Enhances The Induction Of Rat Mammary Tumors By Nitrosomethyl Urea. Cancer Lett 61(1):75-79.
- Bevington 2019**. The Prevalence of People with Restricted Access to Work in Manmade Electromagnetic Environments. J Environ Health Sci 5(1): 01- 12. DOI: 10.15436/2378-6841.19.2402.
- Blackman 1979 et al.** Induction of Calcium-Ion Efflux from Brain Tissue by Radiofrequency Radiation: Effects of Modulation Frequency and Field Strength. Radio Sci 14(6S):93-98.
- Blackman 1993 et al.** Evidence for direct effect of magnetic fields on neurite outgrowth. FASEB J 7(9):801-806.
- Blask 1999 et al.** Melatonin inhibition of cancer growth in vivo involves suppression of tumor fatty acid metabolism via melatonin receptor-mediated signal transduction events. *Cancer Research* 59(Sept. 15):4693.
- Blask 2005 et al.** Melatonin-depleted blood from premenopausal women exposed to light at night stimulates growth of human breast cancer xenografts in nude rats. *Cancer Research* 65(Dec. 1):11174-11184. Abstract available at <http://cancerres.aacrjournals.org/cgi/content/abstract/65/23/11174>.
- Bouché 2019**. Melatonin Levels and Low - Frequency Magnetic Fields in Humans and Rats: New Insights From a Bayesian Logistic Regression. *Bioelectromagnetics* 40:539-552. DOI:10.1002/bem.22218.
- Bracken 1989 et al.** Evaluation of the Amex II and Emdex C Monitors of Personal Exposure to Magnetic Fields in Epidemiologic Studies (meeting abstract). DOE Annual Review of Research on Biological Effects of 50 and 60-Hz Electric and Magnetic Fields, 13-16 November 1989, Portland, OR, p. P-22.
- Brodic 2017 et al.** Self-Organizing Maps Classification with Application to the Low Frequency Magnetic Field Emitted by Portable Computers. International Conference on Applied and Theoretical Computing and Communication Technology.
- Burch 2000 et al.** Melatonin metabolite levels in workers exposed to 60-Hz magnetic fields. *JOEM* 42:2 (Feb), pp. 136-142.
- Byus 1984 et al.** Alterations In Protein Kinase Activity Following Exposure of Cultured Human Lymphocytes to Modulated Microwave Fields. *Bioelectromagnetics* 5(3):341-351
- Cain 1987 et al.** Effects of 60-Hz Fields on Ornithine Decarboxylase Activity in Bone Cells and Fibroblasts (meeting abstract). Bioelectromagnetics Society, 9th Annual Meeting, 21-25 June, Portland, OR, p. 42.
- Calle 1985 et al.** Leukemia in Occupational Groups with Presumed Exposure to Electrical and Magnetic Fields (letter). *N Engl J Med* 313(23):1476-1477.
- Cameron 1985 et al.** Retardation of embryogenesis by extremely low frequency 60-Hz electromagnetic fields. *Phys Chem Med NMR* 17:135-138.
- Carlberg 2017**. Case-control study on occupational exposure to extremely low-frequency electromagnetic fields and glioma risk. *Am J Ind Med.* 2017 Apr 10. doi: 10.1002/ajim.22707.
- Carlberg 2020**. Case-control study on occupational exposure to extremely low-frequency electromagnetic fields and the association with acoustic neuroma. *Environmental Research* 187 109621. <https://doi.org/10.1016/j.envres.2020.109621>.
- Carpenter 2019**. Extremely low frequency electromagnetic fields and cancer: How source of funding affects results. *Environmental Research* 178 108688. <https://doi.org/10.1016/j.envres.2019.108688>.
- Cartwright 1988 et al.** Acute myeloid leukemia in adults: a case-control study in Yorkshire. *Leukemia* 2:687-90.
- Chambers 2015 et al.** High-throughput sequencing of DNA G-quadruplex structures in the human genome. *Nature Biotechnology* 33, 877–881, doi:10.1038/nbt.3295.
- Chartier 1984 et al.** BPA Study of Occupational Exposure to 60-Hz Electric Fields, IEEE Paper 84 SM 693-8.
- Chartres 2022 et al.** Conducting evaluations of evidence that are transparent, timely and can lead to health-protective actions. *Environmental Health* (2022) 21:123. <https://doi.org/10.1186/s12940-022-00926-z>
- Chen 2000 et al.** Effect of EMF exposure on chemically induced differentiation of Friend erythroleukemia cells. *Env Health Persp.* Vol 108, Num 10, October.
- Cherry 2002**. Actual or potential effects of ELF and RF/MW radiation on enhancing violence and homicide, and accelerating aging of human, animal or plant cells. <https://hdl.handle.net/10182/4006>
- Coleman 1983 et al.** Leukaemia Incidence In Electrical Workers (letter). *Lancet* 1(8331):982-983.
- Coleman 1990** MP, Cardis E, Héroux P et al. Extremely-Low-Frequency Electric and Magnetic Fields and Risk of Human Cancer. *Bioelectromagnetics* 11:91-99.
- Davanipour 1995 et al.** Amyotrophic lateral sclerosis and occupational exposure to electromagnetic fields. *Bioelectromagnetics*, Volume: 18, 1, 1997. [https://doi.org/10.1002/\(SICI\)1521-186X\(1997\)18:1<28::AID-BEM6>3.0.CO;2-7](https://doi.org/10.1002/(SICI)1521-186X(1997)18:1<28::AID-BEM6>3.0.CO;2-7)

- de Vocht 2010.** Dirty electricity: what, where, and should we care? *Journal of Exposure Science & Environmental epidemiology* volume 20, pages399–405(2010).
- Deadman 1988** JE, Camus M, Armstrong BG, Heroux P, Cyr D, Plante M, Theriault G. Occupational And Residential 60-Hz Electromagnetic Fields And High-Frequency Electric Transients: Exposure Assessment Using A New Dosimeter. *Am Ind Hyg Assoc J* 49(8):409-419.
- Delgado 1982** et al. Embryological changes induced by weak, extremely low frequency electromagnetic fields. *J. Anat* 134:533-551.
- Demers 1991** et al. Occupational exposure to EMF and breast cancer in men. *Am J Epidemiol* 143:340-47.
- Deruelle 2020.** The different sources of electromagnetic fields: Dangers are not limited to physical health. *Electromagnetic Biology and Medicine.* 2020, vol. 39, no. 2, 166–175. <https://doi.org/10.1080/15368378.2020.1737811>.
- Dietrich 1992** F, Feero WE (Volume I). Dietrich F, Robertson D, Steiner G (Volume II). Safety of High Speed Magnetic Levitation Transportation Systems: Final Report on Magnetic Field Testing of the TR07 Maglev System. Volumes I & II. U.S. Dept. of Transportation Report No. DOT/FRA/ORD-92/09.I, 190 pp. (Volume I); Report No. DOT/FRA/ORD-92/09.II, 366 pp. (Volume II).
- Dihel 1985** et al. Effects Of An Extremely Low Frequency Electromagnetic Field On The Cell Division Rate And Plasma Membrane Of Paramecium Tetraurelia. *Bioelectromagnetics* 6(1):61-71.
- Dixey 1982** et al. 3H-Noradrenaline Release Potentiated in A Clonal Nerve Cell Line by Low-Intensity Pulsed Magnetic Fields. *Nature* 296(5854):253-256.
- DSIH, 1974.** Temporary Rules for Operations by the Personnel of Outside Organizations and the Public in the Zone of Effect of the 750 kV Donbass-Western Ukraine Transmission Line. Department of Safety and Industrial Hygiene, and Ministry of Energy and Electrification of the USSR, Effective date October 1, 1974.
- Duffy 1982** et al. Effects of Intermittent 60-Hz Electric Field Exposure: Circadian Phase Shifts, Splitting, Torpor, and Arousal Responses in Mice (meeting abstract). *Bioelectromagnetics Society, 4th Annual Meeting, June 28 - July 2, 1982, Los Angeles, CA, p. 61.*
- Ebadi 2020** et al. Relationship between the Exposure to Magnetic Fields during Pregnancy and Risk of Abortion: A Review Article. *Int J Pediatr* 2020; 8(8): 11813-818. DOI: 10.22038/ijp.2020.50416.4013.
- Ehret 1980** et al. Circadian and Ultradian Functions in Rats Exposed to High Voltage Electric Fields (meeting abstract). *Bioelectromagnetics Society, 2nd Annual Meeting, 14-18 September, 1980, San Antonio, TX. Bioelectromagnetics* 1(2):200.
- EPRI 1993.** Electric and Magnetic Field Fundamentals. Resource Paper BR-103745. Electric Power Research Institute.
- Esmailzadeh 2019** et al. Electromagnetic Fields Exposure from Power Lines and Human Fertility. *Iran J Public Health.* Vol. 48, No.5, May 2019, pp.986-987.
- Esmailzadeh 2019a** et al. Exposure to Electromagnetic Fields of High Voltage Overhead Power Lines and Female Infertility. www.theijoem.com Vol 10, Num 1; January, 2019.
- Bonnell 1986** et al. Research on Biological effects of Power Frequency Fields. *International Conference on Large High Voltage Electric Systems. FASEB J* 7(9):801-806, Paper 36-08.
- Feychting 1992** et al. Cancer and Magnetic Fields in Persons Living Close to High Voltage Power Lines in Sweden. *Swedish. Lakartidningen* 89(50):4371-4374.
- Feychting 1993** et al. Magnetic fields and cancer in children residing near swedish high-voltage power lines. *Am J Epidemiol* 138(7):467-480.
- Feychting 2005** et al. EMF and Health. *Annu. Rev. Public Health* 2005. 26:165–89.
- Filippini 2020** et al. Environmental and Occupational Risk Factors of Amyotrophic Lateral Sclerosis: A Population-Based Case-Control Study. *Int. J. Environ. Res. Public Health* 2020, 17, 2882; doi:10.3390/ijerph17082882.
- Floderus 1992** et al. Increased Risk of Leukemias and Brain Tumors in Occupational Exposure to Magnetic Fields. *Swedish. Lakartidningen* 89(50):4363-4366.
- Flodin 1986** et al. Background radiation, electrical work, and some other exposures associated with acute myeloid leukemia in a case-referent study. *Arch Environ Health* 41:77-84.
- Foliart 2006.** Magnetic field exposure and long-term survival among children with leukemia. *British Journal of Cancer* 94(1):161-4. DOI: 10.1038/sj.bjc.6602916
- Forssén 2005** et al. Occupational magnetic fields and female breast cancer: A case-control study using Swedish population registers and new exposure data. *American Journal of Epidemiology* 161(Feb. 1):250-259. Abstract available at <http://www.aje.oupjournals.org/cgi/content/abstract/161/3/250>.
- Frazier 1982** et al. Effect of 60-Hz A.C. Electric Fields on CHO-K1 Cells (meeting abstract). *Bioelectromagnetics Society, 4th Annual Meeting, June 28 - July 2, 1982, Los Angeles, CA, p. 50.*
- Free 1981** et al. Endocrinological Effects of Strong 60-Hz Electric Fields on Rats. *Bioelectromagnetics* 2(2):105-121.
- Frydman 1994** et al. Folding of nascent polypeptide chains in a high molecular mass assembly with molecular chaperones, *Nature* 370:111-117.
- Fulton 1980** et al. Electrical Wiring Configurations and Childhood Leukemia in Rhode Island. *Am J Epidemiol* 111(3):292-296.
- Gallagher 1989** et al. Occupational Electromagnetic Field Exposure, Solvent Exposure and Leukemia. *J Occup Med* 32(1):64-65
- García-Minguillán 2019** et al. CT2A Cell Viability Modulated by Electromagnetic Fields at Extremely Low Frequency under No Thermal Effects. *Int. J. Mol. Sci.* 2020, 21, 152; doi:10.3390/ijms21010152.
- Gavalas-Medici 1977.** Effects of Weak Electric Fields on Behavior and EEG of Laboratory Animals. *Neurosci Res Program Bull* 15(1):27-36.
- Gervasi 2019** et al. Residential distance from high-voltage overhead power lines and risk of Alzheimer's dementia and Parkinson's disease: a population-based case-control study in a metropolitan area of Northern Italy. *International Journal of Epidemiology*, 2019, 1949–1957 doi: 10.1093/ije/dyz139.
- Ghadamgahi 2016** et al. Memory loss risk assessment for the students nearby high-voltage power lines-a case study. *Environ Monit Assess.* 2016 Jun;188(6):355. doi: 10.1007/s10661-016-5358-4. Epub 2016 May 18.
- Glaves 2004** et al. Molecular Dynamics Study of Proton Transfer in an Acetylcholinesterase Model. October 2004. *Lehrstuhl für Theoretische Chemie. Ruhr-Universität Bochum.* <http://cpmd.org/downloadable-files/no-authentication/cpmd-tutorial-files/additional-material/triade-report.pdf>
- Goff 1985** et al. Production of abnormal proteins in E. coli stimulates transcription of Ion and other Heat Shock Genes. *Cell* 41:587-595.
- Goodman 1979** et al. Bioeffects of Extremely Low-Frequency Electromagnetic Fields: Variation with Intensity, Waveform, and Individual or Combined Electric and Magnetic Fields. *Radiat Res* 78(3):485-501.
- Goodman, 1986** et al. Sine Waves Enhance Cellular Transcription. *Bioelectromagnetics* 7(1):23-29.
- Goodman 1987** et al. Induction of The Expression of C-MYC Following Exposure of Cultured Cells to Low Frequency Electromagnetic Fields (meeting abstract). *Bioelectrical Repair and*

- Growth Society, Seventh Annual Meeting 11-14 October 1987, Toronto, Ontario, Canada, p. 85.
- Goodman 1988** et al. Exposure of Salivary Gland Cells to Low-Frequency Electromagnetic Fields Alters Polypeptide Synthesis. *Proc Natl Acad Sci U S A* 85(11):3928-3932.
- Goodman 1995** et al. Effects of EM fields on molecules and cells. *International review of cytology* 158, pp. 279-338.
- Gowrishankar 1992** et al. Frequency Dependent Rectification of Surface Receptor Transport in Sinusoidal A.C. Electric Fields (meeting abstract). *Biophys J* 61(2 Part 2):A147.
- Graham 1985** et al. Influence of 60-Hz Fields on Human Behavior Physiology Biochemistry. New York State Power Lines Project, Wadsworth Center for Laboratories and Research, Albany, NY 12201; 129 pp.
- Graham 1987** et al. Further Research on Human Exposure to 60-Hz Fields (meeting abstract). Bioelectromagnetics Society, 9th Annual Meeting, 21-25 June, Portland, OR, p. 28
- Green 1999** et al. A case-control study of childhood leukemia in southern Ontario Canada and exposure to magnetic fields in residences. *Int J Cancer* 82: 161–170.
- Grellier 2014** et al. Potential health impacts of residential exposures to extremely low frequency magnetic fields in Europe. *Environment International* 62 (2014) 55–63.
- Guénel 1993** et al. Incidence of cancer in persons with occupational exposure to EMF in Denmark. *Br J Ind Med* 50:758-64.
- Gundersen 1985** et al. The Effects of ELF Magnetic Fields on Synaptic Function (meeting abstract). Bioelectromagnetics Society, 7th Annual Meeting, 16-20 June, San Francisco, CA, J-22.
- Gundersen 1986** et al. Effects of 60-Hz Electromagnetic Fields on Calcium Efflux and Neurotransmitter Release. New York State Power Lines Project, Wadsworth Center for Laboratories and Research, Albany, NY 12201; 45 pp.
- Gye 2012** et al. Effect of electromagnetic field exposure on the reproductive system. *Clin Exp Reprod Med* 2012;39(1):1-9. <http://dx.doi.org/10.5653/cerm.2012.39.1.1> pISSN 2233-8233 - eISSN 2233-8241.
- Håkansson 2002** et al. Cancer incidence and magnetic field exposure in industries using resistance welding in Sweden. *Occup Environ Med* 59(7):481–486.
- Handcock 1992** et al. Statistical Review of The Henhouse Experiments: the Effects of a Pulsed Magnetic Field on Chick Embryos. *Bioelectromagnetics* 13(5):429-433.
- Hansson 1983**. Power Frequency Electromagnetic Fields Affect the Nervous System. An Experimental Study (meeting abstract). Bioelectromagnetics Society, 5th Annual Meeting, 12-17 June, Boulder, CO, p. 102.
- Hardeland 1993** et al. The significance of the metabolism of the neurohormone melatonin: antioxidative protection and formation of bioactive substances. *Neuroscience and Behavioral Reviews*, 17:347-357.
- Hemming 1992**. Architectural Electromagnetic Shielding Handbook, IEEE Press, New York.
- Heydari 1993** et al. Expression of heat shock protein 70 is altered by age and diet at the level of transcription. *Molecular and Cellular Biology*, May 1993, p. 2909-2918.
- Héroux 1987 P**. 60-Hz Electric and Magnetic Fields Generated by a Distribution Network. *Bioelectromagnetics* 8:135-148.
- Héroux 1987a P**. "Electromagnetic Dosimeter Instruction Manual". Institut de Recherche d'Hydro-Québec. March 1987.
- Héroux 1987b** et al. Electromagnetic dosimeter for investigation of 60-Hz bioeffects. American Industrial Hygiene Association Conference, Montreal, June 1987.
- Héroux 1988 P**. Electromagnetic Exposure Assessment in Epidemiological Health Studies. Meeting of the International Agency for Research on Cancer, Lyon, May 2nd-3rd 1988.
- Héroux 1990 P**. Power Lines and Schools. Canadian Electrical Association Symposium on Health Effects from Electric and Magnetic Fields: Managing the Issue, Montréal, March 29th, 1990.
- Héroux 1991 P**. A Dosimeter for the Assessment of ELF Exposure. *Bioelectromagnetics* 12:241-257.
- Héroux 1992 P.**, Retrospective Magnetic Field Adjustment, Letter to Gilles Thériault, 92/09/23.
- Hosseiniabadi 2019** et al. DNA damage from long-term occupational exposure to extremely low frequency electromagnetic fields among power plant workers. *Mutat Res Gen Tox En* 846 (2019) 403079. <https://doi.org/10.1016/j.mrgentox.2019.07.007>.
- Hosseiniabadi 2019a** et al. The effect of chronic exposure to extremely low-frequency electromagnetic fields on sleep quality, stress, depression and anxiety. *Electromagnetic Biology and Medicine* vol. 38, no. 1, 96–101. <https://doi.org/10.1080/15368378.2018.1545665>
- Hosseiniabadi 2019b** et al. Effect of long-term occupational exposure to extremely low-frequency electromagnetic fields on proinflammatory cytokine and hematological parameters. *International Journal of Radiation Biology*, vol. 95, no. 11, 1573–1580. <https://doi.org/10.1080/09553002.2019.1642542>.
- Hosseiniabadi 2020** et al. The Effects of Antioxidant Vitamins on Proinflammatory Cytokines and Some Biochemical Parameters of Power Plant Workers: a Double - Blind Randomized Controlled Clinical Trial. *Bioelectromagnetics* 00:1-9. DOI:10.1002/bem.22294.
- Hosseiniabadi 2020a** et al. The effect of vitamin E and C on comet assay indices and apoptosis in power plant workers: A double blind randomized controlled clinical trial. *Mutat Res Gen Tox En* 850 - 851 (2020) 503150.
- Hosseiniabadi 2020b** et al. Investigating the effects of exposure to extremely low frequency electromagnetic fields on job burnout syndrome and the severity of depression; the role of oxidative stress. *J Occup Health*. 2020;62:e12136. DOI: 10.1002/1348-9585.12136.
- Huss A 2018**. Occupational extremely low frequency magnetic fields (ELF-MF) exposure and hematolymphopoietic cancers - Swiss National Cohort analysis and updated meta-analysis. *Environ Res*. 2018 Mar 24;164:467-474. doi: 10.1016/j.envres.2018.03.022.
- IRPA 1990**. Interim Guidelines on Limits of Exposure to 50/60-Hz Electric and Magnetic fields. *Health Physics*, Vol 58, no 1, 113-122.
- Ishido 2001** et al. Magnetic fields (MF) of 50-Hz at 1.2 μT as well as 100 μT cause uncoupling of inhibitory pathways of adenylyl cyclase mediated by melatonin 1a receptor in MF-sensitive MCF-7 cells. *Carcinogenesis*, Vol. 22, No. 7, 1043-1048, July 2001.
- Jaffe 1983** et al. Perinatal Exposure to 60-Hz Electric Fields: Effects on The Development of The Visual-Evoked Response in Rats. *Bioelectromagnetics* 4(4):327-339.
- Jalilian 2017**. Occupational exposure to extremely low frequency magnetic fields and risk of Alzheimer disease: A systematic review and meta-analysis. *Neurotoxicology*. 2017 Dec 24. S0161-813X(17)30239-5. doi: 10.1016/j.neuro.2017.12.005.
- Jalilian 2020** et al. Amyotrophic lateral sclerosis, occupational exposure to extremely low frequency magnetic fields and electric shocks: a systematic review and meta-analysis. *Rev Environ Health* 2020; aop.<https://doi.org/10.1515/reveh-2020-0041>.
- Jbireal 2018** et al. Disturbance in haematological parameters induced by exposure to electromagnetic fields. *Hematol Transfus Int J*. 2018;6(6):242–251.
- Juutilainen 1990** et al. Incidence of leukemia and brain tumors in Finnish workers exposed to ELF magnetic fields. *Int Arch of Occupational Environ Health* 62:289-93.
- Kapri-Pardes 2017**. Activation of Signaling Cascades by Weak Extremely Low Frequency Electromagnetic Fields. *Cell Physiol Biochem*. 2017 Oct 16;43(4):1. doi: 10.1159/000481977.

- Kato 1993** et al. Effects of exposure to a circularly polarized 50-Hz magnetic field on plasma and pineal melatonin levels in rats. *Bioelectromagnetics* 14:97-106.
- Kaune 1985** et al. Current densities measured in human models exposed to 60-Hz electric fields. *Bioelectromagnetics* 6:13-21.
- Kaune 1987** et al. Residential Magnetic And Electric Fields. *Bioelectromagnetics* 8(4):315-335.
- Kercher 1980**. The Effects of Low Intensity, Extra-Low Frequency Electromagnetic Fields on Time Perception and The Electroencephalogram. *Diss Abstr Int (B) Sci Eng* 40(8):3997-3998.
- Kheifets 1995**. Occupational electric and magnetic field exposure and brain cancer: a meta-analysis. *J. Occ. Environ. Med.*, 37: 1327-1341.
- Kivrac 2017**. Effects of electromagnetic fields exposure on the antioxidant defense system. *J. Microsc. Ultrastruct.* 2017, 5, 167–176.
- Koeman 2017**. Occupational exposure and amyotrophic lateral sclerosis in a prospective cohort. *Occup Environ Med* 2017;0:1. doi:10.1136/oemed-2016-103780.
- Kokate 2016**. Extremely Low Frequency Electromagnetic Field (ELF -EMF) and childhood leukemia (CL) near transmission lines: a review. *Advanced Electromagnetics*, Vol. 5, No.1, April 2016.
- Kurtz 1986** et al. An ancient developmental induction: heat shock protein induced in sporulation and oogenesis. *Science* 231:1154-1157. March 7th.
- Kwee 1995** et al. Changes in cell proliferation due to environmental non-ionizing radiation ELF electromagnetic fields. *Bioelectrochemistry and Bioenergetics* 36, 109-114.
- Lai 2004** et al. Magnetic-Field–Induced DNA Strand Breaks in Brain Cells of the Rat. *Environmental Health Perspectives*, Volume 112, Number 6.
- Lai 2019**. Exposure to Static and Extremely-Low Frequency Electromagnetic Fields and Cellular Free Radicals. *Electromagnetic Biology and Medicine*. vol. 38, no. 4, 231–248 <https://doi.org/10.1080/15368378.2019.1656645>.
- LeBars 1983** et al. Les effets biologiques des champs électriques: effets sur le rat, la souris, le cobaye. *Recueil de Médecine Vétérinaire*, Octobre 1983, 823-837.
- Lednev 1991**. Possible Mechanism for the Influence of Weak Magnetic Fields on Biological Systems. *Bioelectromagnetics* 12(2):71-75.
- Lee 1994** et al. Electric field-induced concentration gradients in lipid monolayers. *Science*, vol 263, 4th Feb., 655-658.
- Leitgeb 2003** et al. Electrosensitivity and electromagnetic hypersensitivity. *Bioelectromagnetics* 24:387-394.
- Levine 2017** et al. Temporal trends in sperm count: a systematic review and meta-regression analysis. *Human Reproduction Update*, Volume 23, Issue 6, November-December 2017, Pages 646–659, <https://doi.org/10.1093/humupd/dmx022>
- Li 2002** et al. A Population-Based Prospective Cohort Study of Personal Exposure to Magnetic Fields during Pregnancy and the Risk of Miscarriage. *Epidemiology* 13:9-20.
- Li 2009** et al. Maternal occupational exposure to extremely low frequency magnetic fields and the risk of brain cancer in the offspring. *Cancer Causes Control*. DOI 10.1007/s10552-009-9311-5.
- Li 2011**. Maternal Exposure to Magnetic Fields During Pregnancy in Relation to the Risk of Asthma in Offspring. *Arch Pediatr Adolesc Med*. Vol 165 (No. 10), Oct 2011.
- Li 2012 Y**, Héroux P, Kyrychenko I. Metabolic Restriction of Cancer Cells in vitro causes Karyotype Contraction - an indicator of Cancer Promotion? *Tumor Biology* 33(1):195-205. doi: 10.1007/s13277-011-0262-6.
- Li 2012 Y**. The Effects of Hypoxia, Metabolic Restriction and Magnetic Fields on Chromosome Instability and Karyotype Contraction in Cancer Cell Lines. PhD thesis, McGill University, January 2012.
- Li 2013 Y**, Héroux P. Extra-Low-Frequency Magnetic Fields alter Cancer Cells through Metabolic Restriction, *Electromagnetic Biology and Medicine*, DOI:10.3109/15368378.2013.817334, 2013.
- Li 2019Y** and Paul Héroux. Magnetic Fields Trump Oxygen in Controlling the Death of Erythro-Leukemia Cells. *Appl. Sci.* 2019, 9, 5318.
- Li 2020** et al. Association Between Maternal Exposure to Magnetic Field Nonionizing Radiation During Pregnancy and Risk of Attention-Deficit/Hyperactivity Disorder in Offspring in a Longitudinal Birth Cohort. *JAMA Network Open*. 2020;3(3):e201417. doi:10.1001/jamanetworkopen.2020.1417.
- Liboff 1984** et al. Time-Varying Magnetic Fields: Effect On DNA Synthesis. *Science* 223(4638):818-820.
- Liboff 1985**. Cyclotron Resonance Mechanism For Electromagnetic Energy Transfer To Cells (meeting abstract). *Bioelectromagnetics Society*, 7th Annual Meeting, 16-20 June, San Francisco, CA, I-3.
- Liburdy 1992** et al. ELF Magnetic Fields And Melatonin-Induced Growth Inhibition Of ER+ Breast Cancer Cells (meeting abstract). *Annual Review of Research on Biological Effects of Electric and Magnetic Fields from the Generation, Delivery and Use of Electricity Meeting*, 8-12 November, San Diego, CA, U.S. Dept. of Energy, p. A-19.
- Lin 1985** et al. Occupational Exposure to Electromagnetic Fields and the Occurrence of Brain Tumors. An Analysis of Possible Associations. *J Occup Med* 27(6):413-419.
- Lindbohm 1992** et al. Magnetic Fields of Video Display Terminals and Spontaneous Abortion. *Am J Epidemiol* 136(9):1041-1051.
- Litovitz 1994** et al. Super-imposing spatially coherent EM noise inhibits field-induced abnormalities in developing chick embryos. *Bioelectromagnetics* 15:105-113.
- Loomis 1993** et al. Case-Control Study of Breast Cancer Mortality among Female Electrical Workers (meeting abstract). *Annual Review of Research on Biological Effects of Electric and Magnetic Fields from the Generation, Delivery and Use of Electricity*, Savannah, Georgia, October 31st, 1993, p. 115.
- Loscher 1995**, Mevissen. Linear relationship between flux density and tumor copromoting effect of magnetic field exposure in a rat breast cancer model, *Bioelectromagnetics Society Annual Meeting* 95, Boston, p. 78.
- Lyle1983** et al. Suppression of T-Lymphocyte Cytotoxicity Following Exposure to Sinusoidally Amplitude-Modulated-Fields. *Bioelectromagnetics* 4(3):281-292.
- Lyle 1986** et al. Inhibition Of CTL-1 Allogeneic Cytotoxicity In The Presence Of A 60-Hz Sinusoidal Electric Field (meeting abstract). *Bioelectromagnetics Society*, 8th Annual Meeting, 1-5 June 1986, Madison, WI, p. 29.
- Lymangrover 1983** et al. 60-Hz Electric Field Alters the Steroidogenic Response of Rat Adrenal Tissue, in Vitro. *Life Sci* 32(7):691-696.
- Madreperla 1985** et al. Induction of Heat-Shock Protein Synthesis in Chondrocytes at Physiological Temperatures. *J Orthop Res* 3(1):30-35.
- Marron 1983** et al. Cell-Surface Effect Of 60-Hz Electromagnetic Fields. *Radiat Res* 94(1):217-220.
- Mahaki 2019** et al. A review on the effects of extremely low frequency electromagnetic field (ELF-EMF) on cytokines of innate and adaptive immunity. *Electromagnetic Biology and Medicine*. 2019, VOL. 38, NO. 1, 84–95. <https://doi.org/10.1080/15368378.2018.1545668>.
- Mahaki 2019a** et al. The effects of extremely low-frequency electromagnetic fields on c-Maf, STAT6, and ROR α expressions in spleen and thymus of rat. *Electromagnetic Biology and Medicine*, vol. 38, no. 2, 177–183. <https://doi.org/10.1080/15368378.2019.1608832>.
- Mahlum 1977**. Biomagnetic Effects: A Consideration In Fusion Reactor Development. *Environ Health Perspect* 20:131-140.

- Marshall 2016** et al. Electromog and Autoimmune Disease. *Immunol Res* (2016). doi:10.1007/s12026-016-8825-7.
- Maurer 1993.** *Ground Current Magnetic Field Study*. Report of Project EP 90-57. Empire State Electric Energy Research Corporation, New York.
- McCarty 2011** et al. Electromagnetic Hypersensitivity: Evidence for a Novel Neurological Syndrome. *IntematotJal Journal of Neuroscience*, 121 , 670-676, DOI: 10.3109/00207454.2011.608139.
- McDowall 1983.** Leukemia Mortality In Electrical Workers In England And Wales (letter). *Lancet* 1(8318):246.
- Medvedev 1976** et al. Influence of Static and Low-Frequency Magnetic Field on Behavioral and Vegetative Reactions of Human Operator. *Russian. Zh Vyssh Nerv Deiat* 26(6):1131-1136.
- Mevisen 1993** et al. Effects of Magnetic Fields on Mammary Tumor Development Induced by 7,12-Dimethylbenz(a)Anthracene in Rats. *Bioelectromagnetics* 14(2):131-143.
- Mevisen 1995** et al. Possible mechanisms of the tumor copromoting effect of magnetic field exposure in a rat breast cancer model, *Bioelectromagnetics Society Annual Meeting 95*, Boston, p. 50.
- Mikolaichik 1987.** Response of the Endocrine System to Electromagnetic Fields (meeting abstract). *Mechanisms of Biological Action of Electromagnetic Fields*. 27-31 October 1987, Pushchino, USSR, USSR Acad. of Sciences, Res.Center for Biological Studies, Inst. of Biological Physics. Coordination Council of Comecon Countries and Yugoslavia for Res. in the Fields of Biological Physics: 33-34.
- Milham 1982.** Mortality From Leukemia in Workers Exposed to Electrical and Magnetic Fields (letter to editor). *N Engl J Med* 307(4):249.
- Milham 1985.** Mortality in Workers Exposed to Electromagnetic Fields. *Environ Health Perspect* 62:297-300.
- Milhand 2018.** The electronics in fluorescent bulbs and light emitting diodes (LED), rather than ultraviolet radiation, cause increased malignant melanoma incidence in indoor office workers and tanning bed users. *Medical Hypotheses* 116 (2018) 33–39.
- Miller 1991.** Miniature-Probe Measurements of Electric Fields and Currents Induced by a 60-Hz Magnetic Field in Rat and Human Models. *Bioelectromagnetics* 12:157-171.
- Morgan 1993.** Risk Analysis and Management. *Scientific American*, July, pp. 32-41.
- Munro 1984** et al. Use of peptide tagging to detect proteins expressed from cloned genes: deletion mapping functional domains of *Drosophila hsp70*, *The EMBO Journal*, vol 3, p 3087-3093.
- Munro 1985** et al. What turns on heat shock genes ? *Nature* 317:477-478. Oct 10th
- National Institute of Building Sciences 2005.** Indoor Environmental Quality Final Report.
- Noda 1987** et al. Effect of Electric Currents on DNA Synthesis in Rat Osteosarcoma Cells: Dependence on Conditions that Influence Cell Growth. *J Orthop Res* 5(2):253-260.
- Nordenson 1984** et al. Clastogenic effects in human lymphocytes of power frequency electric fields: in vivo and in vitro studies. *Radiat Environ Biophys* 23:191-201.
- Nordenson 1988** et al. Chromosomal Effects in Lymphocytes of 400 kV-Substation Workers. *Radiat Environ Biophys* 27(1):39-47.
- Nordstrom 1983** et al. Reproductive Hazards Among Workers at High Voltage Substations. *Bioelectromagnetics* 4(1):91-101.
- Núñez-Enríquez 2020** et al. Extremely Low - Frequency Magnetic Fields and the Risk of Childhood B - Lineage Acute Lymphoblastic Leukemia in a City with High Incidence of Leukemia and Elevated Exposure to ELF Magnetic Fields. *Bioelectromagnetics* 41:581-597. DOI:10.1002/bem.22295.
- Nussbaum 1989** JH, Grodzinsky AJ. Theoretical Models For Interaction Of Electromagnetic Fields With Biological Tissues. Final Report 1 July 86 - 1 July 88. NTIS Document No. AD-A206 923/5/XAB; 28 pp.
- Ohm 1976** OJ. Interference With Cardiac Pacemaker Function. *Acta Med Scand* 596(Suppl.):87-95.
- Olin 1985** et al. Mortality Experience Of Electrical Engineers. *Br J Ind Med* 42:211-212.
- Ossenkopp 1988** et al. Inhibitory Effects of Acute Exposure to Low-Intensity 60-Hz Magnetic Fields on Electrically Kindled Seizures in Rats. *Brain Res* 442(2):255-260.
- Özgün 2019** et al. Extremely low frequency magnetic field induces human neuronal differentiation through NMDA receptor activation. *Journal of Neural Transmission* (2019) 126:1281–1290. <https://doi.org/10.1007/s00702-019-02045-5>.
- Pearce 1985** et al. Leukaemia In Electrical Workers In New Zealand (letter). *Lancet* 1(8432):811-812.
- Pedersen 2017.** Occupational exposure to extremely low-frequency magnetic fields and risk for central nervous system disease: an update of a Danish cohort study among utility workers. *Int Arch Occup Environ Health*. DOI 10.1007/s00420-017-1224-0.
- Phillips 1986** et al. Transferrin Binding To Two Human Colon Carcinoma Cell Lines: Characterization and Effect of 60-Hz Electromagnetic Fields. *Cancer Res* 46(1):239-244.
- Phillips 1986a** et al. In Vitro Exposure to Electromagnetic Fields: Changes in Tumour Cell Properties. *Int J Radiat Biol* 49(3):463-469.
- Phillips 1986b** JL. Transferrin Receptors and Natural Killer Cell Lysis. A Study Using Colo 205 Cells Exposed To 60-Hz Electromagnetic Fields. *Immunol Lett* 13(6):295-299.
- Phillips 1997** et al. Exposure of molt-4 lymphoblastoid cells to a 1 G sinusoidal magnetic field at 60-Hz: effects on cellular events related to apoptosis, In: 1997 Annual Review of Research on Biological Effects of Electric and Magnetic Fields from the Generation, Delivery, and Use of Electricity; Frederick, MD:W/L Associates, Ltd.
- Pickard 1988.** How to beat KT (meeting abstract). *Bioelectromagnetics Society, 10th Annual Meeting, 19-24 June, Stamford, CT*, p. 27.
- Prichard 2019** et al. Are rises in Electro-Magnetic Field in the human environment, interacting with multiple environmental pollutions, the tipping point for increases in neurological deaths in the Western World? *Medical Hypotheses* 127 76-83. <https://doi.org/10.1016/j.mehy.2019.03.018>.
- Ramirez 1983** et al. Oviposition and development of *Drosophila* modified by magnetic field. *Bioelectromagnetics* 4:315-326.
- Ramon 1981** et al. Inhibition of Growth Rate of *Escherichia Coli* Induced by Extremely Low-Frequency Weak Magnetic Fields. *Bioelectromagnetics* 2(3):285-289.
- Reiter 1992** RJ. Alterations of the Circadian Melatonin Rhythm by the Electromagnetic Spectrum: A Study in Environmental Toxicology. *Regul Toxicol Pharmacol* 15(3):226-244.
- Reiter 1993** et al. Antioxidant capacity of melatonin: a novel action not requiring a receptor. *Neuroendocrinol. Lett* 15:No 1+2, 103-116.
- Ren 2019** et al. Prenatal exposure to extremely low frequency magnetic field and its impact on fetal growth. *Environmental Health* (2019) 18:6. <https://doi.org/10.1186/s12940-019-0447-9>.
- Riley 1995.** Tracing EMFs in Building wiring and grounding, *Magnetic Sciences International*, Tucson, AZ.
- Rozencaiwaj 1987** et al. The role of melatonin and serotonin in aging. *Med. Hypotheses*, 23:337-352.
- Russell 1982** et al. The Effect of Electric Field Exposure on Rat Circadian and Infradian Rhythms (meeting abstract). *Bioelectromagnetics Society, 4th Annual Meeting, June 28 - July 2, 1982, Los Angeles, CA*, p. 101.

- Sadeghi 2017.** Preterm birth among women living within 600 meters of high voltage overhead Power Lines: a case-control study. *Rom J Intern Med.* 2017 Apr 18.
- Safe Housing Ottawa, 2009.** Safe building electromagnetic field design guidelines.
- Salzinger 1987** et al. Behavioral Effects of ELF. New York State Power Lines Project, Wadsworth Center for Laboratories and Research, Albany, NY 12201; 137 pp.
- Sauer 1999** et al. 13-Hydroxyoctadecadienoic acid is the mitogenic signal for linoleic acid-dependent growth in rat hepatoma 7288CTC in vivo. *Cancer Research* 59(Sept. 15):4688.
- Savitz 1988** et al. Case-Control Study Of Childhood Cancer And Exposure To 60-Hz Magnetic Fields. *Am J Epidemiol* 128(1):21-38.
- Savitz 1995** et al. Magnetic Fields in Relation to Leukemia and Brain Cancer Among U.S. Electric Utility Workers. Preliminary study release.
- Schooneveld 2015** et al. Electromagnetic field reduction restores health of electro-sensitive people. Update of Suppl. 9 in EHS Bulletin nr. 42, June 2013.
- Schwan 1980** et al. RF-Field Interactions With Biological Systems: Electrical Properties And Biophysical Mechanisms. *Proc IEEE* 68(1):104-113.
- Seegal 1989** et al. Chronic Exposure Of Primates To 60-Hz Electric And Magnetic Fields: ii. Neurochemical Effects. *Bioelectromagnetics* 10(3):289-301.
- Semikhina 1981** LP, Kiselev VF. Effect of weak magnetic fields on the properties of water and ice. *Russian Physics Journal* 31:5351-54.
- Semikhina 1988** LP, Kiselev VF, Levshin LV, Saletskii AM. Effect of weak magnetic fields on the luminescence-spectral properties of a dye in an aqueous solution. *Journal of Applied Spectroscopy* 48:556-9.
- Seto 1984** et al. Investigation of Fertility and In Utero Effects in Rats Chronically Exposed to a High-Intensity 60-Hz Electric Field. *IEEE Trans Biomed Eng* 31(11):693-702.
- Shestakov 1982** et al. Industrial-Frequency Electromagnetic-Fields as a Factor in the Work Environment (meeting abstract). Russian. All-Union Symposium on the Biological Effects of Electromagnetic Fields, Pushchino, USSR, p. 118-119.
- Shivalingam 2015** A et al. The interactions between a small molecule and G-quadruplexes are visualized by fluorescence lifetime imaging microscopy. *Nature Communications* 6, Article number: 8178 (2015) doi:10.1038/ncomms9178.
- Sikov 1984** et al. Studies On Prenatal And Postnatal Development In Rats Exposed To 60-Hz Electric Fields. *Bioelectromagnetics* 5(1):101-112.
- Sikov 1987** et al. Developmental Studies Of Hanford Miniature Swine Exposed to 60-Hz Electric Fields. *Bioelectromagnetics* 8(3):229-242.
- Silva 1985** et al. Exposure to Transmission Line Electric-Fields During Farming Operations. *IEEE Trans Power Appar Syst* 104(9):2632-2640.
- Skyberg 1993** et al. Chromosome aberrations in lymphocytes of high-voltage laboratory cable splicers exposed to electromagnetic fields. *Scan J Work Environ Health* 19:29-34.
- Sobel 1995** E, et al. Occupational Exposure to Electromagnetic Fields is Associated with Increased Risk of Alzheimer's Disease University of Southern California, USA.
- Soffritti 2016** M et al. Life-span exposure to sinusoidal-50 Hz magnetic field and acute low-dose γ radiation induce carcinogenic effects in Sprague-Dawley rats. *International Journal of Radiation Biology* Vol. 92 , Iss. 4, 2016.
- Spitz 1985** et al. Neuroblastoma And Paternal Occupation. A Case-Control Analysis. *Am J Epidemiol* 121(6):924-929.
- Stam 2011** R. Comparison of international policies on electromagnetic fields (power frequency and radiofrequency fields). Laboratory for Radiation Research, RIVM 118/2011 LSO Sta, National Institute for Public Health and the Environment, the Netherlands. P.O. Box 1 3720 BA Bilthoven, The Netherlands, www.rivm.nl/en/.
- Stern 1986** et al. A case-control study of leukemia at a naval nuclear shipyard. *Am J Epidemiol* 123:980-92.
- Stern 1987** RM. Cancer Incidence Among Welders: Possible Effects Of Exposure To Extremely Low Frequency Electromagnetic Radiation (ELF) And To Welding Fumes. *Environ Health Perspect* 76:221-229.
- Stevens 1987** RG. Electric Power Use And Breast Cancer: A Hypothesis. *Am J Epidemiol* 125(4):556-561.
- Stevens 1992** et al. Electric Power, Pineal Function, And The Risk Of Breast Cancer. *FASEB J* 6(3):853-860.
- Stevenson 1985** et al. Potassium Ion Influx Measurements on Cultured Chinese Hamster Cells Exposed to 60-Hertz Electromagnetic Fields. *Bioelectromagnetics* 6(2):189-198.
- Stuchly 1989** et al. Exposure To Electromagnetic Fields In Arc Welding. *Health Phys* 56(3):297-302.
- Sulkava 1996** R. Update on Alzheimer's. *Work Health Safety* 1996. Finnish Institute of Occupational Health. P. 27.
- Sulzman 1986** et al. Effects of Electromagnetic Fields on Primate Circadian Rhythms. New York State Power Lines Project, Wadsworth Center for Laboratories and Research, Albany, NY 12201; 65 pp.
- Sun 1995** WQ, Héroux P, Clifford T, Sadilek V, Hamade F. Characterization of ELF Magnetic Fields in Schools at the Carleton Board of Education, accepted in *American Industrial Hygiene Association Journal*.
- Svedenstal 1999a** et al. DNA damage, cell kinetics and ODC activities studied in CBA mice exposed to electromagnetics fields generated by transmission lines. *In Vivo*, 13:507-514.
- Svedenstal 1999b** B-M et al. DNA damage induced in brain cells of CBA mice exposed to magnetic fields. *In Vivo* 13:551-552.
- Svendson 2007** et al. Exposure to magnetic fields and survival after diagnosis of childhood leukemia: a german cohort study. *Cancer Epidemiol Biomarkers Prev.* 2007 Jun;16 (6):1167-71.
- Swanson 1994** et al. Power-frequency fields and people. *Eng. Sc. & Educ. Jnl.*, April, 71-79.
- Swerdlow 1983.** Epidemiology of Eye Cancer in Adults in England and Wales, 1962-1977. *Am J Epidemiol* 118(2):294-300.
- Tan 1993** et al. Melatonin: a potent, endogenous hydroxyl radical scavenger. *Endocrine Journal* 1:57-60.
- Tan 1993a** et al. The pineal hormone melatonin inhibits DNA adduct formation induced by the chemical carcinogen safrole in vivo. *Cancer Letters* 70:65-71.
- Tenforde 1986** et al. Power-Frequency Magnetic Field Personal Dosimeter with Data Acquisition Capabilities (meeting abstract). *Bioelectromagnetics Society, 8th Annual Meeting*, 1-5 June 1986, Madison, WI, p. 17.
- Thériault 1994** et al. Cancer risks associated with occupational exposure to magnetic fields among electric utility workers in Ontario and Québec, Canada and France: 1970-1989. *Am. J. of Epidemiology*, 139 (6): 550-572.
- Tomenius 1986** L. 50-Hz Electromagnetic Environment and the Incidence of Childhood Tumors in Stockholm County. *Bioelectromagnetics* 7(2):191-207.
- Tönqvist 1991** et al. Cancer in the electric power industry. *Br J Ind Med* 43:212-3.
- Turner 2014.** Occupational Exposure to Extremely Low-Frequency Magnetic Fields and Brain Tumor Risks in the INTEROCC Study. *Cancer Epidemiology, Biomarkers & Prevention*; 23(9); 1863–72. *American Association for Cancer Research*, June 2014. DOI: 10.1158/1055-9965.EPI-14-0102
- Tynes 1990** et al. EMF and male breast cancer. *Lancet* 336:1596.
- Tynes 2003** et al. Residential and occupational exposure to 50-Hz magnetic fields and malignant melanoma: a population based study. *Occup Environ Med* 60(5):343–347.
- Vagero 1983** et al. Incidence of Cancer in the Electronics Industry: using the New Swedish Cancer Environment Registry as a Screening Instrument. *Br J Ind Med* 40:188-192.

- Vallejo 2019** et al. Effects of long-term exposure to an extremely low frequency magnetic field (15 μ T) on selected blood coagulation variables in OF1 mice. *ELECTROMAGNETIC Biology and Medicine* vol. 38, no. 4, 279–286. <https://doi.org/10.1080/15368378.2019.1641719>.
- van Wijngaarden 2000** et al. Exposure to electromagnetic fields and suicide among electric utility workers: a nested case-control study. *Western Journal of Medicine* 173, 94 - 100.
- Vasquez 1988** et al. Diurnal Patterns in Brain Biogenic Amines of Rats Exposed to 60-Hz Electric Fields. *Bioelectromagnetics* 9(3):229-236.
- Villeneuve 2000** et al. Non-Hodgkin's lymphoma among electric utility workers in Ontario: the evaluation of alternate indices of exposure to 60-Hz electric and magnetic fields. *Occupational and Environmental Medicine*. April 2000, pp. 249-257.
- Villeneuve 2002** et al. Canadian Cancer Registries Epidemiology Research Group. Brain cancer and occupational exposure to magnetic fields among men: results from a Canadian population-based case-control study. *Int J Epidemiol* 31(1):210–217.
- Wang 2016**. Effects of electromagnetic fields exposure on plasma hormonal and inflammatory pathway biomarkers in male workers of a power plant. *Int Arch Occup Environ Health* (2016) 89:33–42. DOI 10.1007/s00420-015-1049-7.
- Wang 2017**. Magnetic Fields and Reactive Oxygen Species. *Int J Mol Sci*. 2017 Oct 18;18(10). pii: E2175. doi: 10.3390/ijms18102175.
- Wartenberg 1998** D. Residential Magnetic Fields and Childhood Leukemia: A Meta-Analysis. *Am J Public Health* 88:1787-1794.
- Weaver 1990** et al. The Response of Living Cells to Very Weak Electric Fields-the Thermal Noise Limit. *Science* 247:459-462.
- Weiderpass 2003** et al. 2003. Occupational exposures and gastrointestinal cancers among Finnish women. *J Occup Environ Med* 45(3):305–315.
- Welker 1983** et al. Effects of an Artificial Magnetic field on Serotonin n-acetyltransferase activity and melatonin content of the rat pineal gland. *Experimental Brain Research* 50:426-432.
- Wertheimer 1979** N, Leeper E. Electrical Wiring Configurations and Childhood Cancer. *Am J Epidemiol* 109(3):273-284.
- Wertheimer 1982** N, Leeper E. Adult Cancer Related To Electrical Wires Near The Home. *Int J Epidemiol* 11(4):345-355.
- Wertheimer 1986** N, Leeper E. Possible Effects Of Electric Blankets And Heated Waterbeds on Fetal Development. *Bioelectromagnetics* 7(1):13-22.
- Williams 1982** GL. Electric Field Experiments On DNA Related Molecular Processes (meeting abstract). *Bioelectromagnetics Society, 4th Annual Meeting, June 28 - July 2, 1982, Los Angeles, CA, p. 87.*
- Wilson 1980** et al. Pineal Gland Function In Rats Exposed To 60-Hz Electric Fields (meeting abstract). *Bioelectromagnetics Society, 2nd Annual Meeting, 14-18 September, 1980, San Antonio, TX. Bioelectromagnetics* 1(2):236.
- Wilson 1986** et al. 60-Hz Electric-Field Effects on Pineal Melatonin Rhythms: Time Course for Onset and Recovery. *Bioelectromagnetics* 7(2):239-242.
- Winters 1984** et al. Enhancement of Human Tumor Cell Growth by Electromagnetic and Magnetic Fields (meeting abstract). *Bioelectromagnetics Society, 6th Annual Meeting, 15-19 July, Atlanta, GA, p. 9.*
- Winters 1986** et al. Virus Suppressor Factors Induced in Cultured Cells by Exposure In Vitro to 60-Hz Ac Magnetic Fields (meeting abstract). *Bioelectromagnetics Society, 8th Annual Meeting, 1-5 June 1986, Madison, WI, p. 31.*
- Wright 1982** et al. Leukemia In Workers Exposed To Electric And Magnetic Fields (letter to editor). *Lancet* 2(8308):1160-1161.
- Yakymenko 2016**. Oxidative mechanisms of biological activity of low-intensity radiofrequency radiation. *Electromagn. Biol. Med.* 2016, 35, 186–202.
- Yang 2019** et al. Involvement of Calcium in 50-Hz Magnetic Field-Induced Activation of Sphingosine Kinase1 Signaling Pathway. *Bioelectromagnetics* 40:180-187.
- Zaffanella 1993** LE. Survey of residential magnetic field sources. Report TR-102759, Electric Power Research Institute.
- Zendehdel 2019** et al. DNA effects of low level occupational exposure to extremely low frequency electromagnetic fields (50/60 Hz). *Toxicology and Industrial Health, Vol. 35(6)* 424–430. DOI: 10.1177/0748233719851697.
- Zhao 2019** et al. Risk of congenital heart disease due to exposure to common electrical appliances during early pregnancy: a case-control study. *Environmental Science and Pollution Research*. <https://doi.org/10.1007/s11356-020-10852-7>.
- Zipse 2003**. The Hazardous Multigrounded Neutral Distribution System and Dangerous Stray Currents. <https://ieeexplore.ieee.org/document/1242596>
- Zmyslony 2000 M et al**. DNA damage in rat lymphocytes treated in vitro with iron cations and exposed to 7 mT magnetic fields (static or 50-Hz). *Mutat Res* 453:89-96.

5. HEALTH EFFECTS OF RADIO-FREQUENCIES AND MICROWAVES 3

5.1. Electromagnetic Radiation Environment..... 3

5.1.1. Electromagnetic Fields are Waves 4
5.1.2. Propagation and Data Rate depend on Frequency 4
5.1.3. EMR Absorption 5
5.1.4. Near and Far Fields 5
5.1.4.1. Near Field..... 5
5.1.4.2. Far Field 7
5.1.4.3. Far-Field Computations..... 7

5.2. Instruments, Probes and Antennas..... 8

5.2.1. Wide Band Instruments 8
5.2.2. Narrow Band Instruments 9
5.2.3. Personal Instruments 9
5.2.4. Antennas..... 10
5.2.4.1. Field Polarization 10
5.2.4.2. Monopole Antennas 11
5.2.4.3. Dipole Antennas 12
5.2.4.4. Parabolic Antennas..... 12
5.2.4.5. Advanced Antenna Evolution..... 13
5.2.4.6. Patch Antennas 14
5.2.4.7. Magnetic Antennas..... 14
5.2.5. Electromagnetic Dosimeters 14
5.2.6. Field and Power Density Measurements 14

5.3. Biological and Health Effects of Electro-Magnetic Radiation 15

5.3.1. Early Regulations on EMR Exposures 16
5.3.1. Penetration of EMR in Biological Tissues 17
5.3.2. Biological Effects of EMR on Specific Organs 18
5.3.3. Effects of EMR on Metabolism 18
5.3.4. Effects of EMR on Reactive Oxygen Species 19
5.3.5. Genetic Effects of EMR 19
5.3.6. EMR Effects on Enzymes and Hormones 19
5.3.7. Cancer and EMR 20
5.3.8. Cancer Epidemiology and EMR 21
5.3.8.1. Brain Cancer..... 22
5.3.8.2. Thyroid Cancer..... 23
5.3.8.3. Breast Cancer 24

5.3.9. Nervous System..... 24
5.3.9.1. Blood-Brain Barrier 24
5.3.9.2. Central Nervous System 25
5.3.9.3. Radiowave Sickness 26
5.3.9.4. Electromagnetic Hypersensitivity 27
5.3.9.5. Memory 28
5.3.9.6. Behavior..... 29
5.3.9.7. Alzheimer’s Disease 29
5.3.9.8. Peripheral Nervous System..... 29
5.3.9.9. Protection of the CNS from EMR..... 29
5.3.10. Immunity 29
5.3.11. Reproduction, Growth and Development 30
5.3.11.1. Reproduction 30
5.3.11.2. Testes and Sperm..... 30
5.3.11.3. Implantation, Growth and Development..... 31

5.4. Applications of Radio-Frequencies and Microwaves 33

5.4.1. Heating using EMR 34
5.4.1.1. Ovens 35
5.4.1.2. Dielectric Heaters 35
5.4.1.3. Induction Heating and Welding 36
5.4.2. Damage due to Heat 38
5.4.2.1. Burns..... 38
5.4.2.2. Acute Heat 38
5.4.2.3. Chronic Heat..... 38
5.4.2.4. Cataracts 39
5.4.3. Electromagnetic Detectors..... 40
5.4.3.1. Metal Detectors..... 40
5.4.3.2. Identification (ID) Equipment 40
5.4.3.3. Electronic Article Surveillance (EAS)..... 40
5.4.3.4. Full-Body Scanners 40
5.4.3.5. Radar..... 41
5.4.3.6. Traffic Radar..... 42
5.4.4. Broadcasting 43
5.4.4.1. Broadcast Transmitters 43
5.4.4.2. Microwave and Satellite Communications 44
5.4.5. Cellular Telephone Deployments 44
5.4.6. Mobiles..... 45
5.4.6.1. SAR 46
5.4.6.2. Computed SARs 47
5.4.6.3. Measured SARs 47

5.4.6.4. SAR Reduction.....	51	5.6.8.3. Radars.....	72
5.4.7. Base Stations: the Killing Fields.....	52	5.6.8.4. Dielectric Heaters.....	73
5.4.7.1. Base Station Exposure Reduction (500 m).....	54	5.6.8.5. Microwave and Short-Wave Diathermy.....	73
5.4.8. Smart Meters.....	55	5.6.8.6. Protecting Explosives.....	73
5.4.9. Cordless Phones.....	55	5.6.9. Improving Data Transmission Techniques.....	74
5.4.10. Computers and Office Local Area Networks.....	55	5.6.9.1. Switching Off.....	74
5.4.11. Laptops.....	55	5.6.9.2. Better Cables.....	74
5.4.12. Internet of Things and 5G.....	55	5.6.9.3. Li-Fi.....	75
5.4.13. Electromagnetic Compatibility (EMC).....	56	5.6.9.4. Project Loon.....	75
5.4.14. Interference Sources.....	57	5.7. Summary.....	75
5.4.15. Filtering.....	57	5.8. Bibliography.....	76
5.4.16. Perspective on Wireless Risks.....	58	5.9. Answers To Problems.....	85
5.4.17. Internet of Things.....	59	5.10. Glossary.....	88
5.4.18. Health Care.....	59		
5.4.18.1. Diathermy.....	59		
5.4.18.2. Oncological Hyperthermia.....	60		
5.4.18.3. Electrosurgical Devices.....	60		
5.4.18.4. Pacemaker Sensitivity.....	60		
5.4.18.5. Nuclear Magnetic Resonance.....	60		
5.4.18.6. Transcranial Magnetic Stimulation (TMS).....	62		
5.4.18.7. Neonatal Incubators.....	63		
5.5. Exposure Standards.....	63		
5.5.1. Recommendations for Protection.....	64		
5.5.2. Protection against Heat.....	66		
5.5.3. Restricted Scope of Government Guidelines based on Heat...	67		
5.5.4. Canadian Guidelines.....	68		
5.6. Control Measures.....	68		
5.6.1. Shielding.....	68		
5.6.1.1. Electric Shielding.....	69		
5.6.1.2. Magnetic Shielding.....	69		
5.6.2. Enclosing Equipment.....	70		
5.6.3. Personal Shielding.....	70		
5.6.4. Increasing Distance.....	70		
5.6.5. Controlled Areas.....	70		
5.6.6. Worker Training.....	71		
5.6.7. Medical Monitoring.....	71		
5.6.8. Safety Procedures.....	71		
5.6.8.1. Children in Schools.....	71		
5.6.8.2. Cellular Phones.....	72		

5. HEALTH EFFECTS OF RADIO-FREQUENCIES AND MICROWAVES

5.1. Electromagnetic Radiation Environment

As measured by *Power Density*, the RF and MW (or ElectroMagnetic Radiation, EMR) environment [Sagar 2018; Birks 2018] is dominated by radio and television broadcasts, in the band of 0.5 to 900 MHz, and by emissions from cellular phone towers between 850 and 2600 MHz.

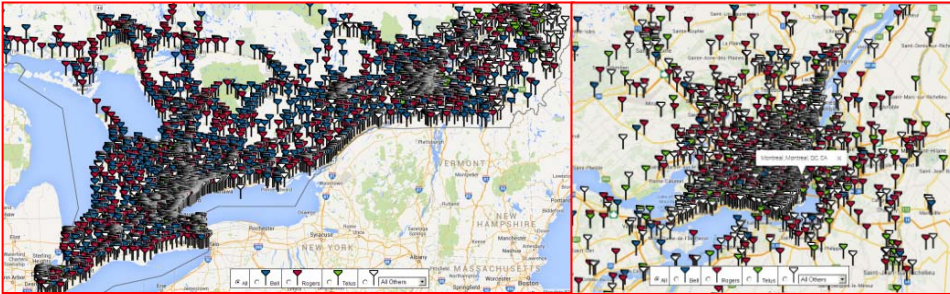

Provinces of Ontario, Quebec (left), and the city of Montreal (right) experienced a proliferation of cellular towers.

System	Power Density ($\mu\text{W}/\text{m}^2$)
AM and FM, Analog Signals	< 10,000
Digital TV (DVB-T)	3 - 40,000
GSM (2G), 900, 1800 MHz	0.2 – 20,000
UMTS (3G), 700, 3500 MHz	0.2 – 1,000, growing

Power Densities in the European Community

Domestic EMR exposures come from cordless phones (DECT, 120 mW at 1880-1900 MHz), WiFi (2.4, 2.48, 5.15, 5.35, 5.47,

5.72 GHz), and utility smart meters. The median exposure at the start of the century, about $50 \mu\text{W}/\text{m}^2$, is growing rapidly, due to the popularity of cellular communications, and the superposition of competing systems.

For example, the average exposure in France is about $2,700 \mu\text{W}/\text{m}^2$, with 90% below $1,300 \mu\text{W}/\text{m}^2$, and with crests of $270,000 \mu\text{W}/\text{m}^2$, all within regulation limits of 4,500,000 to $10,000,000 \mu\text{W}/\text{m}^2$.

In Switzerland, the average daily exposure to EMR has been estimated at $130 \mu\text{W}/\text{m}^2$ (range of 14 to $881 \mu\text{W}/\text{m}^2$), according to a study of 166 subjects monitored for one week.

Although Power Density ($\mu\text{W}/\text{m}^2$) is the simplest to describe the EMR environment, biologically relevant variables are modulation type and crest factor of the radiation. Note that the Power Density Limits are computed from the electric or magnetic field limits according to:

$$PDL = \frac{E^2}{377} = B^2 \times 377$$

where 377 Ohms stands for the impedance of free space (plane wave assumption).

Telecommunication systems require consideration of wavelength, which varies from 50 cm to millimeters. Since a certain level of signal is required at the receiver, wave propagation, reflection, and interference patterns are taken into account.

In AM and FM receivers, transmitted signal variations are compensated by Automatic Gain Control circuitry, while in cellular systems, rapid and automatic changes in *frequency* and *intensity* of the radiation manage to reliably maintain the needed signal level available at the receiver's location. This means that our exposure to these signals is highly variable, but that users are essentially unaware of these variations.

5.1.1. Electromagnetic Fields are Waves

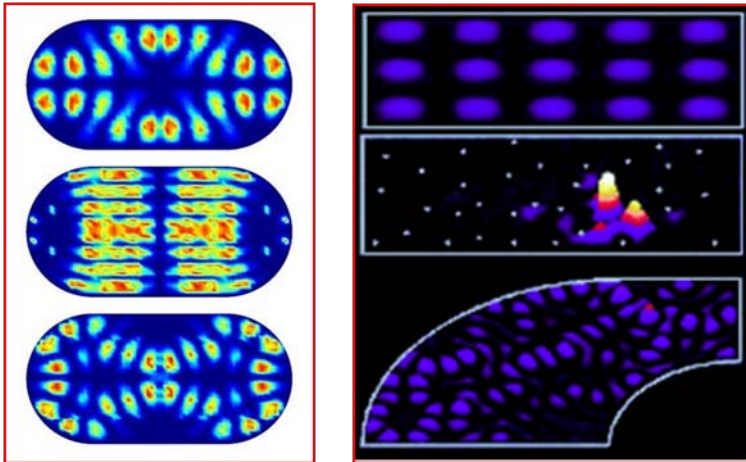

MWs trapped in a cavity seen from above can show a regular standing-wave pattern (as in the rectangular box at the top right), but if vertical electrical wires null the field at irregularly spaced locations (white dots), surprising concentrations occur. Odd-shaped boundaries at the bottom left, and right produce special patterns [Sridhar et al, Stein et al, 1992]. Peaks appear sharper than wavelength.

5.1.2. Propagation and Data Rate depend on Frequency

For AM broadcasting stations (540 to 1600 kHz), a maximum broadcast antenna gain of 10 is used, and the maximum antenna input power allowed is 50,000 W. For VHF TV and FM broadcasting stations, the maximum effective radiated power (ERP) is as follows: 100 kilowatts for channels 1 to 6, 316 kilowatts for channels 7 to 13, and 550 kilowatts for FM broadcast. For UHF TV stations, the maximum allowed is 5,000 kilowatts.

↑ broadcasting uniformity
- - -
data rate capacity ↓

AM Radio	0.5 – 1.7	MHz
CB Radio	26 – 27	MHz
Cordless Phones	43 – 50	MHz
TV Channels 2-6	54 – 88	MHz
FM Radio	88 – 108	MHz
TV Channels 7-13	174 – 216	MHz
Maritime	457	MHz
UHF TV Channels 14-51	470 – 698	MHz
700 MHz band	698 – 793	MHz
800 MHz Cellular NA (1G →)	824 – 891	MHz
900 MHz ISM Band NA	902 – 928	MHz
900 MHz GSM Band	880 – 960	MHz
1800 MHz GSM Band	1710 – 1880	MHz
1900 PCS NA (2G →)	1850 – 1990	MHz
3G →	1885 – 2200	MHz
4G: many bands between	1700 – 2100	MHz
2.4 GHz ISM Band NA Bluetooth, WiFi, cordless phones, point-to-point, ovens	2.4	GHz
2.5 GHz WiMax	2.5	GHz
5 GHz ISM Band NA WiFi, point-to-point	5.0	GHz

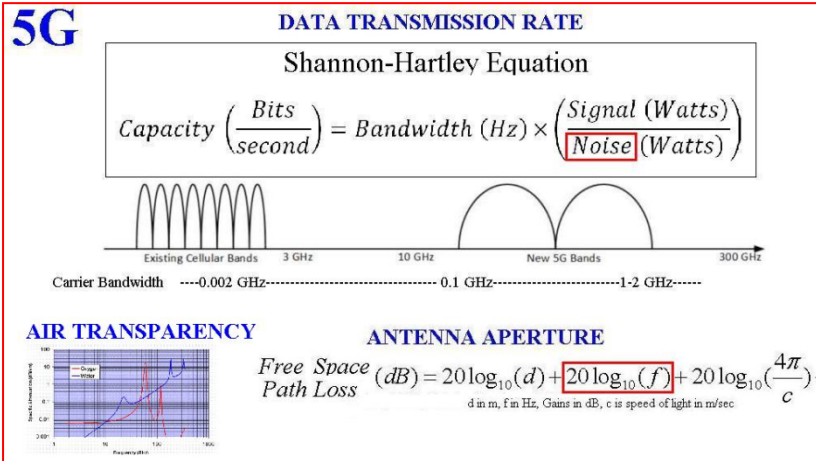

At higher frequencies (above, 5G), bandwidth is wider, but propagation is generally more difficult around obstacles and through structures, because radiation behaves more like light (line-of-sight).

5.1.3. EMR Absorption

Some military circumstances (stealth against radar) require surfaces with very low coefficients of reflection¹, supplied by materials with a dielectric constant and a magnetic permeability equal to that of free space. Ferrite tiles can provide 10-25 dB of absorption between 30MHz and 1GHz. Broadband foam absorbers are shaped as wedges that steadily increase impedance from "free space" at the incident surface of the absorber to a high impedance, lossy material at the rear surface.

¹ Some materials can be designed for very low coefficient of reflection to EM radiation. The US SR-71 Blackbird is a high performance spy-plane made almost entirely of titanium, and covered with a special epoxy coating reducing the reflection of radar waves, thus making it the original *stealth* plane.

At frequencies above a few GHz, water vapor and oxygen absorb some EMR. At higher frequencies, shorter wavelength also means lower energy transfer to antennas (lower “antenna aperture”).

Stealth planes:

SR-71A

F-117A



5.1.4. Near and Far Fields

A source of EMR is surrounded by a volume called the *near-field*. Beyond this volume, another region, the *far-field*, exists. In the *far-field*, the radiation is said to be of “plane wave” geometry (see also 3.1.1.2), **with a fixed ratio between E and B.**

Near and far field distinctions are relevant to exposures from personal equipment as opposed to environmental sources, such as the remote towers and antennas [Bhatt 2015; Bhatt 2016].

5.1.4.1. Near Field

In many occupational health situations involving a worker in close proximity to a source, the E and B fields are not simply coupled (*near field* condition). The electric and magnetic fields must be measured or computed separately.

In the *near field* of a radiating source (which extends from the source itself and out to a given distance), there is no simple relation between the E and B fields. In the *near field*, the decays are not intuitive, and may oscillate with distance: the

energy density present at every point can still be evaluated from electric and magnetic components as:

$$U = U_E + U_H = \frac{1}{2} (\epsilon E^2 + \mu H^2)$$

An example of such an energy evaluation is shown below.

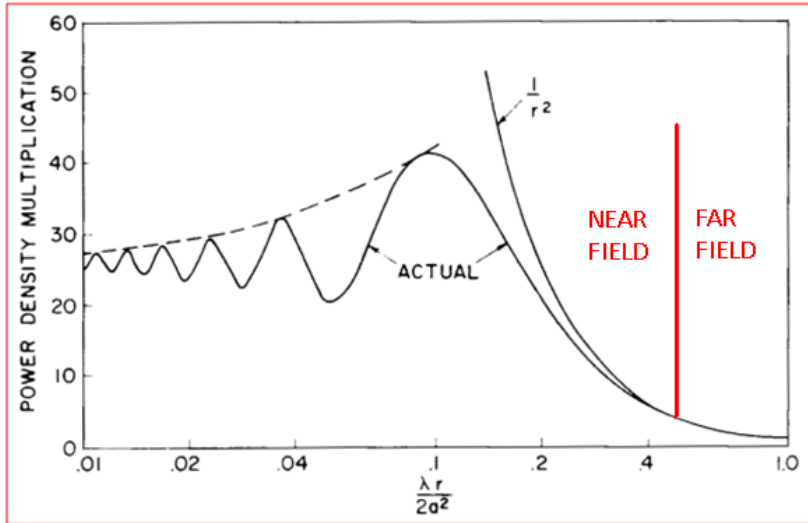

Power density vs distance (r) along the axis of an antenna of diameter “a”. λ is the wavelength of the radiation. The transition distance corresponds to the red bar [Polk, 1986].

The transition between near and far fields can be understood if one pictures a calm lake into which an object falls. Relatively near to the impact point, the waves induced by the object on the lake will be strongly influenced by the shape of the object. Much further away, the wave front will assume a spherical shape, and will be determined by the properties of the water, the distant object remaining only as the source of energy for the motion of the lake surface.



Problem 39. The maximum amplitude of the electric field vector in a plane wave in free space is 275 V/m.

(a) what is the amplitude of the magnetic field vector?

(b) what is the rms value of the electric vector?

(c) what is the power density, in mW/cm², in this EMR?

How does one know whether a given region is in the *far* or *near* field? The numerical criteria for the limit between the two fields:

When $D > \lambda$,
$$\text{Transition Distance} = 2 \frac{D^2}{\lambda}$$

D is the main dimension of the radiator, and λ is the wavelength.

A reasonably good approximation of the fields from *free field* equations is still valid as close as $0.33 D^2/\lambda$ from the antenna.

Note that the “radiator” can be a whip or dipole antenna, or the location of a leak in the door-seal of a MW oven.

When $D < \lambda$,
$$\text{Transition Distance} = \lambda/2\pi.$$

In the case of the radiation of a 100 km power line (60 Hz), the transition distance is 800 km.

In the case of a 1 cm opening in the door of a MW oven (2.45 GHz), the limit would be 1.95 cm. Therefore, the extent of the near field depends on the *dimension of the source, and on the frequency radiated.*

All these cautions should not give the impression that measurements in the near field are impossible. The factors that tend to work against accurate estimates in the near field must be recognized, however.

For example:

- since the ratio between E and B fields is not guaranteed in the near field, a low value obtained with a probe measuring one of the two fields may hide a high value of the other field,
- oscillating-wave patterns in the near field must be investigated by making measurements over many wavelengths of space, a practical difficulty when the wavelength is large,
- the probe measuring the field should not be excessively close to any object (not less than 20 cm), because the readings may be influenced by capacitive coupling between the source and the probe,
- an isotropic probe with 3 orthogonal transducers may not sum the vectorial components correctly in the near field, because the phase between vectorial components is not known.

Transition Distance

Find the Near-Far Field Transition Distance for a parabolic antenna 5 m in diameter uplinking to a satellite in orbit at a frequency of 8 GHz.

$$TD = 2 \frac{D^2}{\lambda} = \frac{2D^2 f}{c} = \frac{2 \times 5^2 m^2 \times 8 \times 10^9 \text{ sec}}{\text{sec} \times 300,000 \text{ km}}$$

$$TD = 1,333 \text{ m}$$

5.1.4.2. Far Field

In the far field, a tight coupling between electric and magnetic fields exists as a result of fundamental properties of space, and in that case, separate estimations for each field can be avoided.

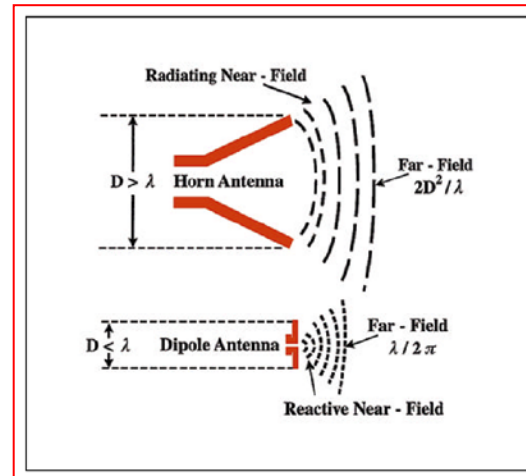

For so-called *plane EMR waves*, the magnetic field vector amplitude can be obtained from the electric field vector amplitude (and vice versa) simply by dividing the electric field amplitude value by the *impedance of free space*, 377 Ohms.

$$\frac{E (V/m)}{B (A/m)} = 377 \Omega$$

In that situation (*far field* condition), the electric field value *or* the magnetic field value will describe the radiation field completely.

Further properties of the *far field* are that the electric and magnetic fields are at right angles to each other, at right angle to the direction of propagation, and that **the power density decays as 1/r²**.

5.1.4.3. Far-Field Computations

When located in the **far-field** of a source, the plane-wave power density can be computed as:

$$P = \frac{E^2}{Z} = B^2 Z$$

P is the *power density* (Watts per square meter), E the electric field (Volts per meter), B the magnetic field (A/m) and Z = 377 Ohms.

Electric field values can be transformed into *plane wave power densities* through this expression. In practice, an approximate evaluation of near-field power densities from electric field data alone is often made in spite of the inaccuracy, and is referred to as the “**equivalent far-field power density**”.

Note on computing the properties of light and EMR radiation: the wavelength of EMR radiation in vacuum or in air can be computed as: $\lambda = c/f$, where λ is the wavelength in meters, c is the speed of light, 300,000 km/sec and f is the frequency in Hz (or 1/sec). For 60 Hz, $\lambda = 5,000$ km. The energy contained in a photon (grain of light) is computed as $W = hf$, where W is in Joule, h is 6.626×10^{-34} J.s and f is frequency in Hz.

A few unit conversions:

$$\begin{aligned} 1 \text{ W} &= 1000 \text{ mW} \\ 1 \text{ m}^2 &= 10,000 \text{ cm}^2 \\ 1 \text{ W/kg} &= 1 \text{ mW/g} \\ 1 \text{ W/m}^2 &= 0.1 \text{ mW/cm}^2 = 1,000,000 \text{ } \mu\text{W/m}^2 \\ 1 \text{ mW/cm}^2 &= 10 \text{ W/m}^2 \end{aligned}$$

5.2. Instruments, Probes and Antennas

5.2.1. Wide Band Instruments

Most instruments monitoring EMR are “Wide Band”. They do not provide detailed information about the EMR (frequency, modulation, etc), but integrate *power density* as $\mu\text{W/m}^2$ readings, irrespective of frequency. They can be sensitive to a wide range of frequencies², and are relatively inexpensive.

Measurements must take into account **sensor orientation if the sensor is not omnidirectional (isotropic)**. In other words, the direction of the electric or magnetic fields (*polarization*) must be determined from *different orientations of the sensor*. The omnidirectionality of a probe can be easily checked

² Dipole antennas are coupled to wide-bandwidth diode detectors.

experimentally by **turning it in an EMR**: *the reading should be unchanging if the measurement is truly omnidirectional*. Isotropic probes are made using **3 orthogonal dipoles**. Two axes of a 3-axis system are shown at left. The sensors are shielded from infra-red radiation by a spherical insulating shell, and against electrostatic charges by semi-conductive material.

Although the dipole sensors are basically frequency-dependent (because of their length), the bandwidth can be extended considerably by using “lossy-dipole” construction.

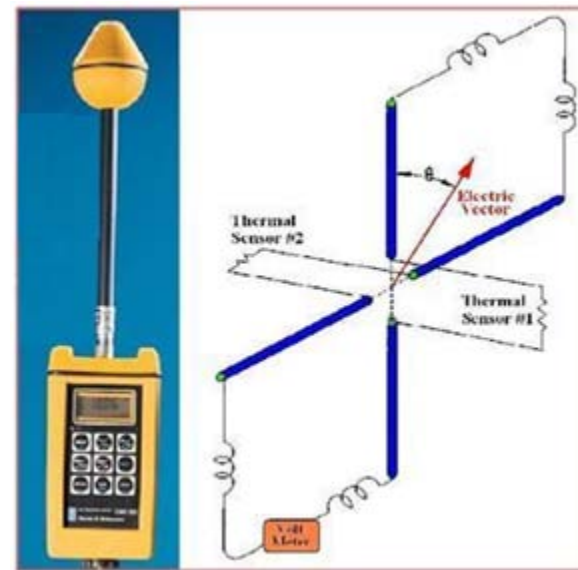

Narda EMR-20

Diagram of 2 (of 3) dipoles measuring the electric-field inside an EMR Survey Meter.

The probe used to measure the field may disturb the field. This is why many

probes feature electrically resistive leads which tend to minimize this disturbance, which can also be minimized by using a transducer of minimum size as compared to the wavelength of the radiation.

The Narda instrument illustrated here is an example of a wide-band detector (100 kHz- 3 GHz) for the isotropic measurement of electric fields. They operate from batteries, are portable and rugged. They can be applied to assess radiation from

equipment such as induction heaters, plastic welding machines, diathermy equipment and other medical instruments producing short-wave radiation, MW ovens, drying equipment in the tanning and timber industries, and radio, TV and cellular transmitters. These instruments also have averaging circuits to measure power density in modulated fields. To get accurate data from these survey instruments, insure that *frequency* and *dynamic range* are appropriate to the source surveyed.

Wide band instruments are incapable of resolving the fast modulation of the EMR signals (how the basic frequency of the carrier wave is altered in amplitude or frequency over time to carry information). The modulations may contain video (TV), audio (radio) or other digital (smart phones) information. Wide band instruments should be immune to infra-red and to atmospheric temperature variations.

5.2.2. Narrow Band Instruments



Rhode & Schwarz FSW85
2 Hz to 85 GHz.

A **narrow band instrument** is like a radio receiver, with a variable tuned frequency.

Narrow band instruments

are not used in health surveys because of their cost, but have great selectivity. As in any other measurement situation, *the hygienist must be aware of the frequency and amplitude limits of the instrument and probe available.*

Narrow band instruments should have a good rejection of sources of radiation other than the ones being monitored. A familiar example of interference is the noise in the AM radio of a car as a motorcycle passes by. The motorcycle may have exposed spark plugs which generate wideband noise.



A narrow bandwidth instrument allows identification of the contributions of different frequency components. In actual deployment of telecommunications systems, the co-location of many broadcasting antennas in certain sites (see photo)

creates the need to determine from which tower excessive radiation originates. New survey instruments like the Narda SRM-3000, illustrated following, have a frequency analysis capability that allows discrimination between co-located sources, which is relevant to modern regulation.



Problem 46. A MW survey meter that reads in dB is calibrated to read -8 dB in a field whose power density is 0.1 W/m^2 . It is then used in a radiation survey, and gives a reading of +2.5 dB at a certain point in a MW field. What is the power density at that point?

5.2.3. Personal Instruments

Electrically hypersensitive persons need to monitor their environment, as well as the locations where they go, to avoid debilitating exposures. Depending on individuals, these exposures can be from power frequency magnetic fields (50-60 Hz), electrical parasites (“dirty electricity”, in great part from switching power supplies), or telecommunications signals, or

all of them. A number of inexpensive instruments have been created to fill their need.



A modern unit with USB data download as well as memory for 1 sec interval measurements for ELF and RF fields over a day is the GQ-EMF-390.

Accuracy of measurements is impossible to maintain (except for ELF magnetic fields) in a hand-held instrument without a separate probe. The ability to such equipment to

measure and display accurately peak field values, important since most telecom signals have large crest factors, is limited. In inexpensive instruments, it is difficult to obtain very high frequencies, accuracy, or large dynamic range. Instruments may not detect accurately below 10 nT (ELF) or 10 $\mu\text{W}/\text{m}^2$. Nevertheless, such instruments can be perfectly adequate to protect a sensitive person from the environment, if exact field values are not needed. It should also be realized that ordinary AM-FM radios tuned between stations, and set at high volume, can be used to detect sources of “dirty electricity”.

Problem 45. How many dB attenuation of power density are required to reduce a 1 W/cm^2 field to 1 mW/cm^2 ?

5.2.4. Antennas

An antenna can emit or receive radiation. Every antenna has frequency-dependent sensitivity or emission efficiency. It also has a particular detection or emission pattern, according to direction (azimuth). It can also be horizontal or vertical (polarization). **Antennas that measure the electric field are mostly in the shape of dipoles or monopoles** (see below), while antennas that measure the magnetic field are in the shape of wire loops.

Isotropic Radiation

If a broadcasting antenna on top of a tower is emitting uniformly 35,000 W of power, what power density can be expected at a distance of 100 m from the source?

$$PDL = \frac{35,000 \text{ W}}{4\pi (100^2 \text{ m}^2)} = 0.278 \frac{\text{W}}{\text{m}^2} = 0.0278 \frac{\text{mW}}{\text{cm}^2}$$

5.2.4.1. Field Polarization

For line-of-sight communications, for which polarization can be relied upon (no reflections), it can make a large difference in signal quality to have the transmitter and receiver use the same polarization. In the early days of FM radio (88-108 MHz), stations broadcast horizontal polarization. In the 1960's, FM radios became popular in automobiles, which used vertical receiving whip antennas. Rules were then changed to allow FM stations to broadcast elliptical polarization (horizontal and vertical) to improve reception to vertical receiving antennas, as long as the horizontal component was dominant.

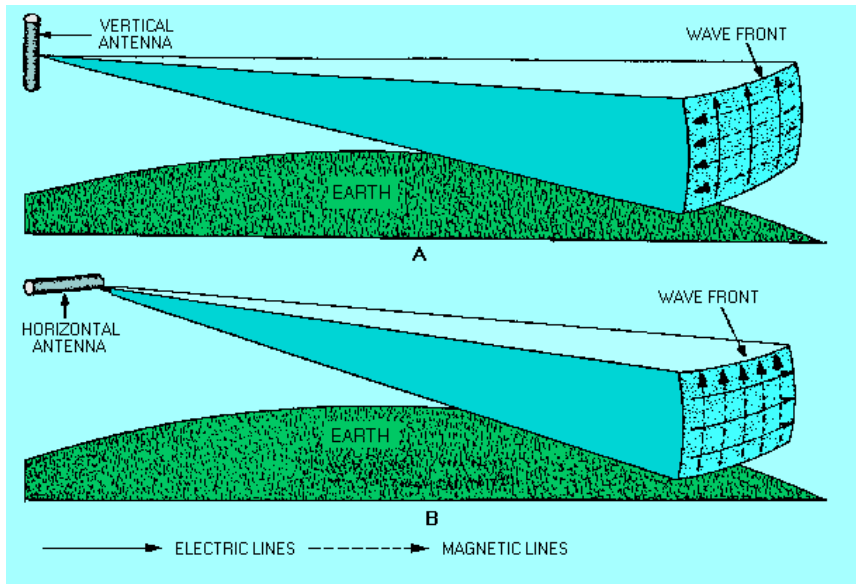

Vertical polarization is common for radio broadcasting and for mobile units. Vertical polarization also works well in the suburbs, or out in the country, especially where hills are present. Most two-way Earth to Earth communications in the frequency range above 30 MHz also use vertical polarization. **Horizontal polarization** is used to broadcast television in North America. This discriminates against vertically polarized stations, such as mobile radio. Also, man-made radio noise is predominantly vertically polarized, and the use of horizontal polarization provides some discrimination against interference from noise.

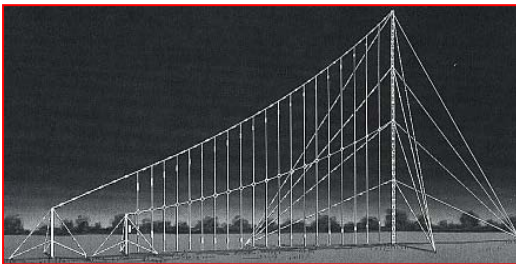

The figure shows an array of dipoles of various lengths used for broadcasting. The waves are vertically polarized.

Circular polarization (right-hand-circular, RHC, or left-hand-circular, LHC) is most often used on satellite communications. This is particularly desired since the polarization of a linear polarized radio wave may be rotated as the signal passes through any anomalies (Faraday rotation) in the ionosphere. Furthermore, due to the position of the Earth with respect to the satellite, geometries may vary, especially if the satellite moves with respect to the Earth-bound station. Circular polarization will keep the signal constant, regardless of these changes.



Hammerhead sharks searching for flatfish in the sand move their head back and forth, as if using a metal detector. Is the hammerhead's dipole detector more finely tuned directionally than the linear antenna [Wueringer 2012], of the sawfish?



5.2.4.2. Monopole Antennas

The whip antennas (Marconi antennas) installed on cars are good examples of monopoles. Because the voltage is applied to the antenna with reference to general ground potential (the metal car body), the results from this configuration are not completely predictable. It is used for omnidirectional reception and emission, and its main weakness, unpredictable gain, is compensated by *automatic gain control circuits* in the radio's electronic circuits.

5.2.4.3. Dipole Antennas

The dipole is also commonly used to emit or receive EMR. In the figure below, the Dipole Antenna (two red straight wires) is fed by a 2 conductor transmission line. The dipole is equivalent to an ideal Current Element source, that is, charges moving back and forth along a single straight wire.

Because voltage is applied between two elements of known geometry in a dipole, its emission or sensitivity can be known exactly. Dipoles have their maximum efficiency, either in emission or in reception, at a length of approximately 0.9 wavelength units. According to the orientation of the two poles, the dipole is directional. The maximum gain of a dipole is generally 2.5 dBi. An animated simulation of emissions from a vertical dipole is provided in the Study Guide.

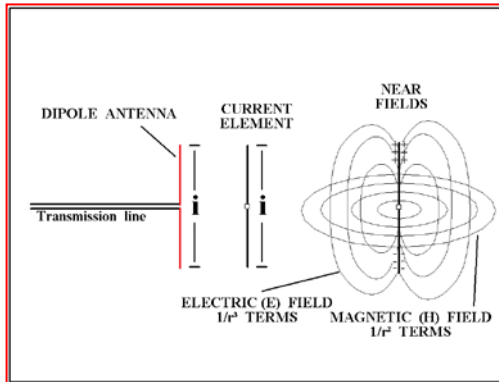

an animated simulation of emissions from a vertical dipole is provided in the Study Guide.

Electric and magnetic fields near to a dipole element, due to source current.

When a dipole is supported by a number of reflectors to amplify

its characteristics, a *Yagi antenna* is obtained, which is recognized as the most common form of an aerial TV antenna. A Yagi antenna (below) can be an emitter or a receiver. In a Yagi array, only one dipole, the active element, is energized, the others (reflector and directors) acting to focus the radiation beam, or to enhance sensitivity in a targeted direction. The gain of a Yagi antenna in one direction can be as high as 20 dBi. Highly directional antennas need to be significantly larger than the wavelength.

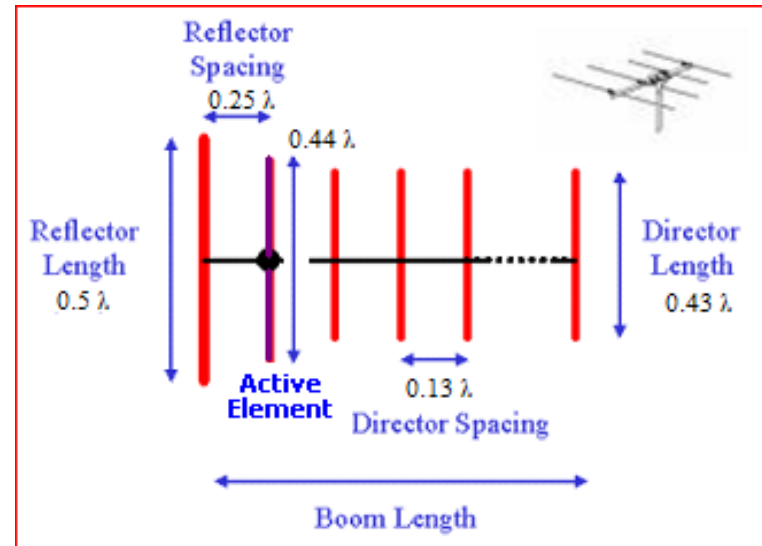

The polar (circular) plot is for a 10-element Yagi. The red numbers scale the radiation emitted towards each azimuth, relative to the main beam expressed in decibels (the main beam = 0 dB).

Antennas that are required to be very small compared to the wavelength sacrifice efficiency, and cannot be very directional. Fortunately at higher frequencies (UHF, MWs) trading off performance to obtain a smaller physical size is usually not required.

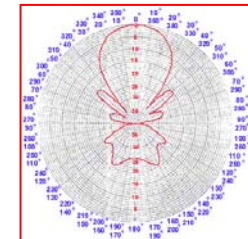

5.2.4.4. Parabolic Antennas

Parabolic antennas are now a common sight, as a result of the proliferation of MW relay stations, and especially of satellite TV dishes. Those antennas are designed for emission in a specific

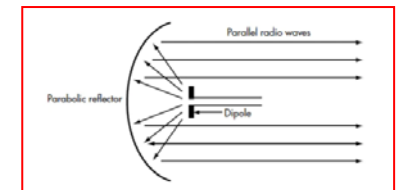

direction (MW relays) or for highly sensitive reception from a chosen source (such as in radio-astronomy). At their focus, emitters or receivers of various types can be placed, such as horns connected to waveguides, or dipoles.³

Antenna Gain

What would be the Effective Radiated Power (the apparent brightness) of a 35,000 W source at a distance of 100 m if the antenna had a maximum gain of 39 dB, and you stood right in the center of the beam?

$$PDL = \frac{35,000 \text{ W}}{4\pi (100^2 \text{ m}^2)} = 0.278 \frac{\text{W}}{\text{m}^2} = 0.0278 \frac{\text{mW}}{\text{cm}^2}$$

$$39 \text{ dB} = 10 \log \frac{PDL_1}{PDL_2}$$

$$\frac{PDL_1}{PDL_2} = 7,943$$

$$ERP = 0.278 \times 7,943 \text{ W/m}^2 = 2,208 \text{ W/m}^2 \text{ or } 221 \text{ mW/cm}^2$$

5.2.4.5. Advanced Antenna Evolution

The simplest radar antenna is the rotating parabolic reflector. The next key advance was the planar array, a much more capable design consisting of many radiators arranged to operate

³ Whenever use is made of radio frequency detection instruments, an antenna factor must be taken into account to calibrate between the field value detected and the mVolts of signal at the instrument input. The antenna factor usually varies with frequency, and must be compensated for, unless the instrument is designed to take its variation into account as:

$$E = V A_f$$

where E is the incident electric field strength (V/m), V is the antenna voltage at the receiver input terminal, A_f is the antenna factor (m⁻¹).

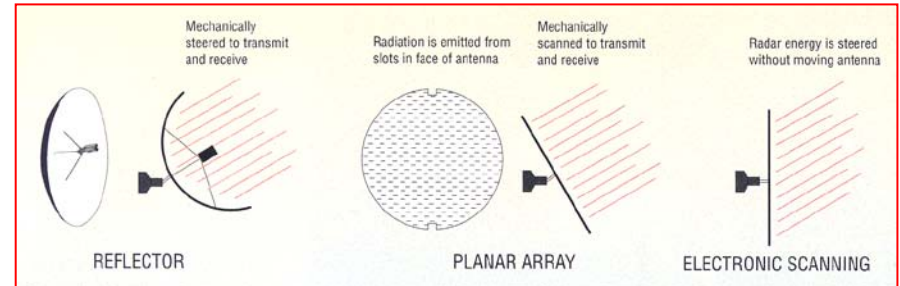

through apertures in a flat surface, but that still steers the beam mechanically.

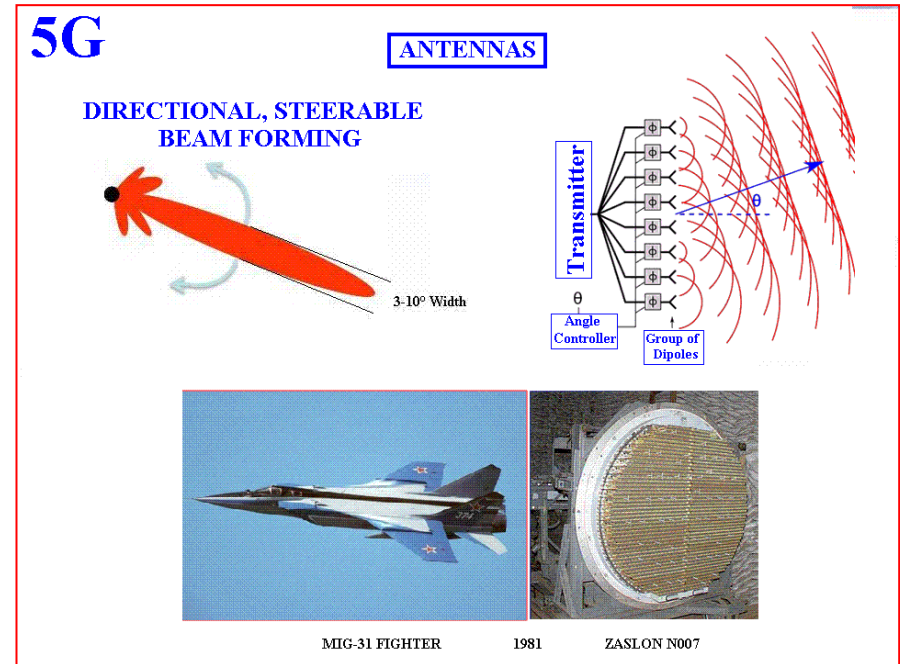

Then came electronic scanning radars, which can electronically steer the beam without moving the antenna, by shifting the phase of the individual dipole signals. Such phased-array radars can instantaneously direct beams of radar energy of various widths over a wide area by changing θ , yielding near-

instantaneous scanning, while a typical mechanically-scanned antenna can take 12-14 seconds to complete a scan. The first such radar to enter service was the N007 Zaslon for the MiG-31 fighter aircraft (1981). The 1.1 m diameter phased-array antenna weighs 300 kg. The whole radar weighs 1000 kg, and operates in the 9-9.5 GHz band. Maximum search range is 300 km for a large airborne target.

Advanced fighter aircraft radar antennas now use a collection (1500) of small transmitter/receivers called an *active array* that extends the capability even further, and allows brief and precisely targeted radar pulses that are very difficult to detect by the enemy.

5.2.4.6. Patch Antennas

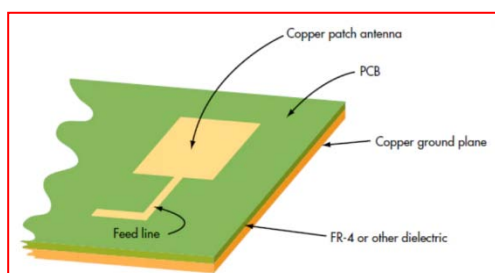

In cellular phones in particular, minaturization is critical. The patch or microstrip antenna is common at microwave frequencies (greater than 1 GHz). It's a

square or circular patch of conductive material about one half-wavelength across. It is usually implemented on a printed-circuit board.

5.2.4.7. Magnetic Antennas



Most antennas are designed to pick-up the electric component of EMR, but there are also some specialized for the magnetic components, as pictured here (Rhode & Schwarz HFN-2-Z2, 9 kHz-30 MHz range).

Problem 47. Broadband instruments are used in EMR hygiene to monitor exposure conditions. State two important technical characteristics of these instruments and indicate how these characteristics are implemented in the construction or taken into account in the use of the instruments.

5.2.5. Electromagnetic Dosimeters

Difficult problems with RF dosimeters are reliability of calibration, and difficulty in controlling the interaction of the unit with the body, depending on position [de Miguel-Bilbao 2018; Aminzadeh 2018]. Pocket systems can perceive radio signals between 50 MHz and 6 GHz, and divide radiation into channels of bandwidth of 10 MHz each. Dynamic ranges of 110 dB are attainable, with tolerance of radiated powers up to 300 W at a distance of one meter from the source. Accuracy is improved if devices are calibrated individually [Eeftens 2020].

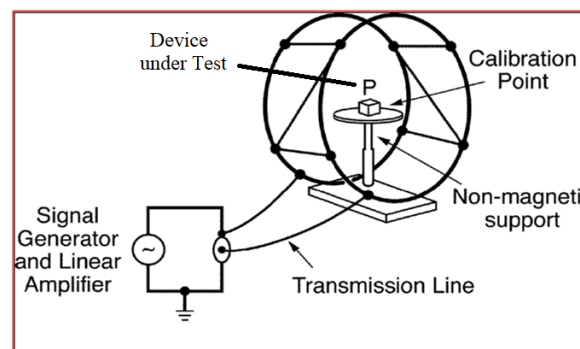

A magnetic system to calibrate sensors at frequencies below 10 MHz.

5.2.6. Field and Power Density Measurements

Measurement procedures for EMR radiation for the purpose of hygiene can be described as follows:

- ✚ gather information on source frequency, power, modulation, antenna orientation, emission pattern and scanning,
- ✚ find the acceptable power density, as well as electric and magnetic field limits at the exposed's location,
- ✚ with this information, turn again to the practical situation to compare by calculation the radiation of the source to the limits to be achieved,
- ✚ in case of doubt, perform measurements, using equipment appropriate to the bandwidth and intensity of the source.

Hygiene Measurements near Radiating Sources:

Below 30 MHz, assessment of situations may require measurements of both the E and B field.

Between 30 and 300 MHz, it may be sufficient to use computation of Power Density from only one field (electric or magnetic).

Beyond 300 MHz, only the E field is measured. Measurements should be performed more than 20 cm from any object, to avoid couplings with the probe, and in the absence of the body of the worker, if possible.

Multiple Sources

One of the great problems of the EMR environment is the multiplications of sources of radiation having diverse characteristics. Simultaneous exposure to EMR of different frequencies (for example, 50 Hz, 27 MHz, 280 MHz) and modulation (FM, 1G, 3G, WiFi and UMTS) can cause more pronounced and more numerous changes in biological parameters than a single exposure to EMR. With combined

exposures, biological impacts can be induced by very low Power Densities.

5.3. Biological and Health Effects of Electro-Magnetic Radiation

“Biological effects” have often been understood as a prelude to the determination of more concerning “health effects” in humans. But the breadth of influence of EMR on all living systems has given “biological effects” an expanded meaning. This is because all biota shares bio-molecular mechanisms, and because human life is influenced by the survival of pollinators and of vegetation, both of which are sensitive to EMR.

Evidence that WiFi exposures stress bacteria (*Escherichia coli* 0157H7, *Staphylococcus aureus* and *Staphylococcus epidermis*, *Pseudomonas aeruginosa*) and enhance their biofilm formation even has implications for the management of serious diseases caused by infectious bacteria [Said-Salman 2019; Movahedi 2019].

EMR, as most other agents, has multiple effects on living systems. It was predicted in 1968 that hydrogen bonds and molecular oscillations at frequencies between 100 and 1000 GHz are of biological significance [Frohlich 1968]. A few basic mechanisms can fan out into a large number of consequences, as biology is inherently complex.

Beyond hydrogen bonds and charge transitions, there are at least two non-thermal effects of EMR to worry about: disruptions in metabolism, and increased production of free radicals (ROS). These basic mechanisms in turn influence stress protein, calcium release, DNA damage, reproduction, chronic disease, and cancer.

The literature can be perceived as confusing because, in place of a reasonably simple chemical exposure, the physical variables of EMR studies are many: frequency, polarization

(direction of field vectors), modulation (AM, FM, pulse or continuous wave), power density, field pattern (near-field, far-field, uniformity of field), measuring and calibration techniques (dosimetry), radiating technique (antennas), chamber materials and dimensions (housing biological subjects) [Sánchez-Montero 2017; Tang 2018]. The baseline field conditions (zero exposure) are very rarely controlled across all frequencies, because of technical difficulties.

Window effects have been reported, and it is expected that classic dose-responses may not always apply to EMR, because it acts in part as a disturbance on homeostatic physiological systems, rather than as a simpler chemical aggressor [Hinrikus 2018]. Hormesis has also been detected [Sun 2016] in EMR effects. There is a large literature documenting non-thermal biological effects [Van Zandt 1987].

5.3.1. Early Regulations on EMR Exposures

By the late 1950s, when EMR technology was spilling into the industrial and civilian sectors, a need for some standard of exposure became apparent. That period also corresponded to detailed investigation of the health effects of ionizing radiation, following the atomic bomb. The scientific exploration that led to the conclusion that *ionizing* radiation could produce human cancers suggested to some that *non-ionizing* radiation (frequencies longer than UV) could not produce cancer, or any other biological effect, because it did not have the “energy to breakup molecules”.

The US standard setting process began around 1960 at a meeting between the American National Standards Institute, the US Navy and the Institute of Electrical and Electronics Engineers. At that time, a number of limits were being used since 1953 by various groups, as shown below.

US Air Force	100,000,000 $\mu\text{W}/\text{m}^2$
General Electric	10,000,000 $\mu\text{W}/\text{m}^2$
Bell Laboratories	1,000,000 $\mu\text{W}/\text{m}^2$
Soviets	100,000 $\mu\text{W}/\text{m}^2$

It took until 1966 for a first ANSI-IEEE standard to be issued, which supported the military level (100,000,000 $\mu\text{W}/\text{m}^2$).

Differences of opinion by a factor of 1000 existed between scientists in the East and the West. The Soviets based their cautiousness on observations of perturbations of the nervous system. The difference of opinion resulted from different philosophies, and on how the restoration of steady-state after an EMR challenge is interpreted. If a biological system can apparently recover from an insult within a short period of time, does this mean that the impact is innocuous or tolerable? By placing the focus on very short-term effects at the exclusion of anything else, a restricted view of toxicity satisfied the proponents of high limits.

The Western standard was under the influence of industrial producers and the military [Pockett 2019], and represents an excellent guide to avoid *hyperthermia*. It had considerable influence in the Western world in the sense that the lead of the ANSI-IEEE standard was followed in many Western countries [Polk 1986]. In contrast, the better USSR regulation was based on evidence of **perturbations of the nervous system and cardiovascular function by low-level radiation** (at 1,000,000 $\mu\text{W}/\text{m}^2$). But the USSR standard allowed incremental increases in occupational exposures, each by a factor of 10, for durations shorter than 2 hours and 20 minutes, so as to facilitate military applications.

In April 2013, the International Agency for Research on Cancer (IARC) classified EMR as *possibly carcinogenic to*

humans (Group 2B), because of positive associations between exposure from wireless phones and

- Glioma, a malignant type of brain cancer (40% increased risk of glioma in heavy users of wireless phones, 30 minutes per day, over a 10-year period) [Wang 2018], and
- Acoustic Neuroma.

Problem 48. A worker, 55 years old, has gone to the company's medical supervisor claiming compensation because his physician has diagnosed a cataract in his left eye. The worker relates the cataract to a full body exposure he believes he has received two weeks ago when there was a malfunction on a 22 kW, 1.5 GHz edge glue-dryer. The medical exam report simply states the observation of a cataract in the left eye, otherwise the examination is unremarkable. What are your recommendations to the company's medical supervisor?

5.3.1. Penetration of EMR in Biological Tissues

The penetration of EMR into biological tissues is quantified by an interfacial **coefficient of reflection**.

The more similar the properties of the two media, the more transmission occurs. The fraction of incident energy reflected by a boundary is given by the coefficient of reflection **squared**. Since the coefficient of reflection (R) between air and skin-muscle varies between 82 and 74% in the range of 0.43 to 10 GHz (see below), **approximately half of the incident EMR energy (R²) is transmitted at an interface between air and body surface**.

The radiation transmitted into the biological material is progressively attenuated. This is specified by the *penetration depth*, the distance within tissue where the wave has fallen to 14% of its original Power Density.

Penetration diminishes markedly with frequency, as shown in the table below. Since dielectric loss (heating) is proportional to frequency, higher frequencies have increased heating ability, but penetrate less.

F, GHz	Saline	Blood	Muscle (skin)	Lung	Fat (bone)
0.43	28	37	30	47	163
0.91	25	30	25	45	128
2.45	13	19	17	23	79
5.8	7	7	8	7	47
10	2	3	3	3	25

Depth of Penetration into Biological Tissues in mm

A MW oven using 2.45 GHz has a penetration depth into muscle of about 2 cm, a good value for cooking.

At 10 GHz, the penetration depth, the level at which 37% of the field intensity remains, is 4 to 6 mm. At 50 GHz, the penetration depth is 1 mm. Within the first mm of the skin, cells divide to renew the stratum corneum. UV light, known to cause skin cancer, has a penetration depth less than 0.1 mm.

Above 100 GHz (mm-waves), most absorption is in *cutaneous tissue*, 0.1 to 1 mm. Therefore, sensations are similar to infrared, which is detectable at 6,700,000 μW/m², 87,000,000 μW/m² being very warm or hot. Detection delay is about 1 sec.

An unusual sensation of typical MW warmth is its persistence following cessation of the stimulus, probably deriving from inertia of the heated tissues: greater penetration of heat allows in depth tissue heating

The first wide-scale application of EMRs was radar, during the Second World War. Within the context of the war effort, radar MWs were *universally perceived as innocuous*, and challenges to this notion were perceived as unpatriotic in the US, because the military depended heavily on radar applications. After the war, the invention of the high power *magnetron* allowed more powerful emitters to be designed.

TISSUE	REFERENCE
Bone	Guo [2018]
Brain	Lai and Singh [1995; 1996; 1997a; 2005] Lai [1997] Mausset [2001] Testylier [2002] Beason and Semm [2002] Maussset-Bonnefont [2004] Vorobyov [2004] Wang [2005] Bartieri [2005] Paulraj and Behari [2006] Xu [2006] Lopez Martin [2006] Mugunthan [2016] Al-Serori [2018] Alkis [2019] Asl [2020] Usman [2020]
Cancer cells	Phillips [1998]
Eye	Lixia [2006] Sun [2006]
Fibroblasts	Diem [2005]
Hearing	Kumar [2018] Yang [2020]
Heart	Usman [2020]
Kidney	Eslami [2019] Guo [2020] Türedi [2017] Mahmoudi [2018] Deniz [2017a]
Liver	Fahmy [2021] Guo [2020] [Postaci, 2018]
Lung	Zhang [2006]
Lymphocytes	Gandhi and Anita [2005] Markova [2005] Zhang [2002] Gulati [2020]
Pancreas	Masoumi [2018]
Progenitor cells	Grasso [2020]
Sperm	Aitken [2005] Sarkar [1994]
Stem cells	Nikolova [2005]

5.3.2. Biological Effects of EMR on Specific Organs

Non-thermal EMR biological effects have been documented to affect practically all organs, most often using variables connected to oxidative stress. Animal models are frequent, but there is plenty of human evidence as well (table below).

The nervous system, a target because of proximity of cell phones to the head, will be discussed more extensively below.

5.3.3. Effects of EMR on Metabolism

Li and Héroux [2013, Chapter 4] reported effects on the structure of water, based on changes in hydrogen bond dynamics (electrons and protons). The ATP Synthase channel

is filled with water, and its modification alters the activity of oxidative phosphorylation [Esmekaya 2016; Lasalvia 2018].

Effects on *free charges* (electrons and protons) means low thresholds of action that may extend in frequency as far as 10 GHz [Kiselev 1988]. This opens the possibility of wide interactions with enzyme activity, and points to potential targets, tissues that depend on large supplies of oxygen and ATP, such as cancer cells, heart, nervous system, spermatozoa, immune cells, kidney, pancreas, liver and any rapidly dividing tissues.

Responses starting at extremely low field intensities have been repeatedly observed in biological systems. For example, 6 GHz stimulation of Leghorn hybrid chickens at $0.0002 \mu\text{W}/\text{m}^2$ resulted in significantly higher fertility [Kondra 1970]. Recent work confirms that in human subjects, cellular phone radiation enhances glucose metabolism [Volkow 2011], which suggests the inhibition of oxidative metabolism expected through alteration of ATP Synthase's proton transparency.

Changes in ATP Synthase performance would have effects not only acutely (the release of calcium) but also chronically on metabolism, possibly affecting the rates of many chronic diseases. It should be remembered that alterations in atmospheric levels of oxygen (mostly consumed in mitochondria) had drastic influences on the course of biological evolution, and that an environment rich in EMR may alter evolution with comparable power. Because the nervous system, like immune system cells, is highly dependent on oxygen metabolism (thus, ATP supply), the brain endothelium would rate as a highly sensitive target [Chaitanya 2014], and this is why "Start of Permeability Loss of Blood-Brain Barrier" is in red in the "Landmarks and Limits" table of section 5.5.1.

5.3.4. Effects of EMR on Reactive Oxygen Species

There are extremely numerous reports documenting increases in ROS associated with EMR exposures [Yakymenko 2018]. Exposure to EMR can induce ROS [Kulaber 2017; Marjanovic 2017, 2017a; Novoselova 2017; Ertilav 2018] and compensating production of glutathione in the liver [Mortazavi 2017; Barnes 2018], which can nevertheless be overwhelmed [Kamali 2018; Kerimoglu 2018] or countered with anti-oxidants [Özsobaci 2018].

5.3.5. Genetic Effects of EMR

Many reports of effects occur at non-thermal levels. When one considers that there are many substantiated reports of occupational exposures *above* the thermally-based limits, the hygiene task to be accomplished is obvious.

A commonly reported lesion from EMR is DNA single strand breaks, likely as a result of ROS [Akdag 2018], and this effect was confirmed by the National Toxicology Program test on animals [NTP 2016; Smith-Roe 2019], with DNA damage significantly increased in the frontal cortex of male mice (with both CDMA and GSM), peripheral leukocyte of female mice (CDMA only) and hippocampus of male rats (CDMA only).

Another report showed that microwaves or EMR emitted from mobile phones (GSM at 915 MHz and UMTS at 1947 MHz) inhibited the formation of tumor suppressor TP53 binding protein 1 (53BP1) foci - a marker of DNA double-strand break repair activity in human primary fibroblasts and mesenchymal stem cells [Markova 2005; Markov 2010]. This is possibly related to repair activity seen as a reduction in karyotype instabilities elsewhere [Li 2013].

Micronuclei count was elevated in cells exfoliated from the mouth of human cell phone users [Vanishree 2020].

Comet Test

The Comet Test is often used in investigating DNA damage, either *in vivo* or *in vitro*. After exposure, cells are obtained as a suspension and laid down on a slide in a thin agarose gel. Once

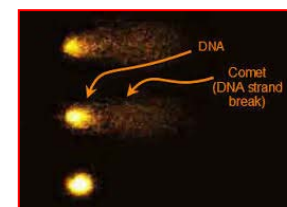

on the slide, the lysed cells are subjected to electrophoresis in neutral or basic medium. The pH, which influences the level of DNA uncoiling, determines in part whether single strand or double-strand DNA breaks are detected by the method. The nuclear material can be stained after electrophoresis, and breaks in DNA appear graphically as a tail from the round location of the nucleus, thus the name “Comet Test”. Study of the length of these tails is indicative of DNA damage. The comet assay, the standard in the measurement of genotoxicity, is exquisitely sensitive to the detection of DNA damage in individual cells. It was used initially to assess sulfuric acid-potassium permanganate mixtures in coordination with the Ames test. Applications followed with the insecticide lindane, organic mercury compounds, 1-chloro-methyl-pyrene, as well as documenting the anti-genotoxic activities of lactic acid bacteria. The test is able to provide information on individual cells and both on damage to DNA, and on alteration of the ability of cells to repair DNA. The test has been extensively used to document the effects of EMR radiation.

5.3.6. EMR Effects on Enzymes and Hormones

Modifications of hydrogen bonds has potential to alter many biological events. Beyond effects on ATP Synthase, other significant effects were reported on the structure of cytochrome P450 reductase [Tanvir 2016], NAD⁺-dependent Isocitrate dehydrogenase [Hagras 2016] and succinate-lactate

CANCER

Using laboratory experiments on cells, it has been obvious for years that the FCC limits do not protect us. Now, we have a succession of experiments on animals (rats and mice) that is entirely convincing.

Chou (1992)
Repacholi (1997)
Lerchl (2015)
NTP (2019)
Ramazzini (2019)

Experimenting on animals is the best method we have of predicting impacts on human populations. Take advice from 4,288 rats and 2,180 mice...or are they biased?

Not only is there overwhelming cell and animal evidence, but there is also human evidence from epidemiology.

dehydrogenase [Zakharchenko 2016]. Investigations of MW action on the enzyme acetylcholinesterase (AChE), an enzyme which catalyzes the hydrolysis of the neurotransmitter acetylcholine, have been numerous [Nikogosjan 1960; Baranski 1967; Servantie 1974; Nakas 1981; Lai 1987; Dutta 1982] and have generally concluded that as a result of prolonged action of low-level MW fields, the level of acetylcholine increased in brain tissue, and the activity of acetylcholinesterase decreased, an intriguing connection with electrical burns [Héroux 1993].

The acetylcholine system is involved in learning and wakefulness. Constant EMR (10-300 MHz) at an intensity of up to 200 V/m, as well as constant MW (2,880 MHz) with power densities ranging from 10,000 $\mu\text{W}/\text{m}^2$ to 10,000,000 $\mu\text{W}/\text{m}^2$ induced changes in LH and FSH levels in the rat pituitary. At first, EMR stimulated secretion of these hormones, but, after repeated exposures, the levels of these

hormones in the pituitary body were significantly diminished. Hypothalamus extracts from animals exposed to MWs stimulated LH and FSH secretion by the anterior hypophysis to a lesser degree than the hypothalamus extracts from control rats. The changes in LH and FSH levels in the pituitary body were detected for Power Densities ranging from 100,000 $\mu\text{W}/\text{m}^2$ to 100,000,000 $\mu\text{W}/\text{m}^2$.

There are reports of EMR effects on the endocrine system of children [Sangun 2014, 2015] and adults [Eskander 2012].

5.3.7. Cancer and EMR

A succession of animal studies have shown the carcinogenicity of EMR, the most recent the NTP study [National Toxicology Program 2018]. But each study, when released, was challenged by industry [Hardell 2020], and eventually forgotten in terms of enacting protection for users.

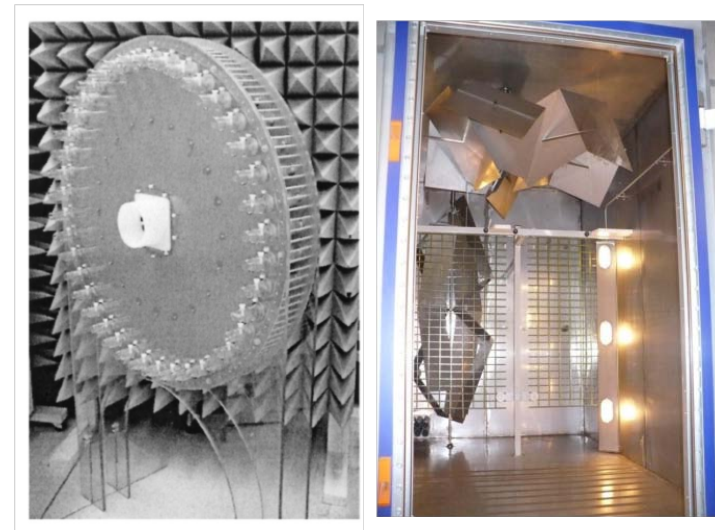

The US National Toxicology Program conducted experiments in rats and mice on health hazards from GSM- and CDMA-

modulated cell phone radiation. Rodents were exposed for 10-minute on, 10-minute off increments, totaling just over 9 hours a day from before birth through 2 years of age. This exposure found tumors in the brains and hearts of male rats [NTP 2018]. The tumors in the brain and heart observed are of a type similar to tumors observed in some epidemiology studies of cell phone use, supporting the International Agency for Research on Cancer (IARC) conclusions regarding the carcinogenicity of EMR. DNA was assessed using the Comet assay, and the frontal cortex is where the NTP saw the most significant increases in DNA breaks.

Considerable efforts to create a reverberation chamber exposure system: a shielded room with an antenna and a vertical and horizontal paddle to create a homogeneous 2G electromagnetic environment (below). Field exposure is from all directions and all polarizations. The NTP results have also been supported by a study focusing on far-field radiation from the Ramazzini Institute in Italy [Falcioni 2018].

This was not the first animal study to report such effects. A US Air Force study conducted from 1980 to 1982, which was documented in a series of nine technical reports found that 18% of 100 male rats exposed to low-intensity microwave radiation for two years developed cancer, as compared to only 5% of 100 rats in the sham-exposed control group. The relative risk of developing cancer in the wireless radiation exposure group was 4.46 ($p = 0.005$) [Chou 1992].

The results obtained by Repacholi [1997] in transgenic mice are reproduced in the form of a graphic abstract.

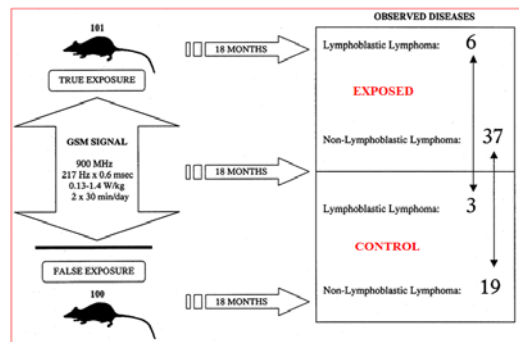

5.3.8. Cancer Epidemiology and EMR

Cancers of various types have been associated with a variety of EMR sources.

In a wide-ranging study, an increase in proportional mortality ratio (2.6) for myeloid and unspecified leukemia among male amateur radio operators in the states of Washington and California (from a total of 1691 deaths) was found [Milham 1988], while lymphatic and monocytic leukemias showed no excess.

Lester [1982, 1982a] published on the incidence of cancer in US counties (over the period 1950-69) which hosted or not an Air Force Base with a military **radar** operating for a period of about 30 years. Exposure to the radar emissions may account for a significantly higher incidence of mortality due to cancer.

Evidence on cancer incidence increases in the **Polish military** by Szmigielski [1996] covered 15 years (1971-85), with approximately 128,000 persons per year. For brain and nervous system tumors, a significantly increased ratio of observed to expected (OER=1.91) was found. Other malignancies with significantly increased incidence in exposed were: esophageal and stomach cancers, colorectal cancers, melanoma, and leukemia/lymphoma.

In 2002, a strong association between local melanoma incidence and the number of local **FM transmitters** in Sweden. A follow-up investigated melanoma incidence and the average density of FM transmitters (87.5–108 MHz) in 23 different European countries. Incidences of melanoma, breast cancer and all cancers together per country correlated with average density of transmitters per 10,000 km². Melanoma and breast cancer, as well as all cancers together, were significantly associated with the density of main FM broadcasting transmitters in the countries examined [Hallberg 2016].

EMR exposures amplify the incidence of cancers generally when connected with **cellular phone** use [Choi 2020], and specifically in specific organs like brain, thyroid and colon [MWN 2020], because of proximity.

Epidemiological studies on excess risk for hemato-lymphatic and other cancers together with brain tumors in cellphone users, and experimental studies on EMR and carcinogenicity make a coherent case for a cause-effect relationship and classifying EMR exposure as a human IARC Group 1 carcinogen [Peleg 2018]. This is causing leading epidemiologists to call for reclassification of EMR from IARC 2B to 1 [Miller 2018, 2019].

5.3.8.1. Brain Cancer

Brain tumors, accounting for the majority of CNS tumors, are rare. The age distribution has two peaks: incidence is about 35 cases per million per year below 10 years of age (which is mainly due to tumors originating from mesodermal and embryonic tissues, medulloblastoma and astrocytoma of the juvenile pilocytic type), and after age 15, there is a steady increase of incidence with increasing age, reaching its second peak of about 200 cases per million per year at an age around 75 years. The burden of CNS cancers is distinctly higher in children, making up around 20% of all childhood malignancies, while in adults less than 2% of all cancers are primary brain

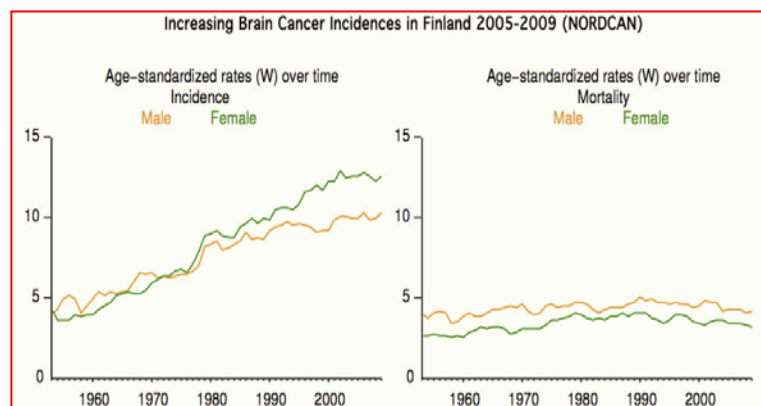

cancers.

Two early job-title investigations have linked EMR to brain cancers, specifically astrocytomas [Lin 1986; Thomas 1987].

The deployment of cellular phones has re-ignited the debate over the historical tendencies of brain cancer over time (as shown below for Finland). Many meta-analyses are attempting to resolve the heated disputes about the carcinogenicity of cellular phone use. Cellular phones have been implicated in increased cancer rates for relatively rare tumors, such as acoustic neuromas, after 10 years of use [Hardell 2002; Hardell 2007; Lonn 2004].

However, the latency period for many solid tumors is 10 to 20 years, so it is possible that the use of cell phones is just old enough (more than 10 years) for cancer risks to start appearing [Moscovitz 2014].

The Interphone Study (Australia, Canada, Denmark, Finland, France, Germany, Israel, Italy, Japan, New Zealand, Norway, Sweden, and the United Kingdom) supplied 792 regular mobile phone users diagnosed with a glioma between 2000 and 2004. Similar to earlier results, a statistically significant association between the intracranial distribution of gliomas and the self-reported location of the phone [Grell 2016; de Vocht 2016; Yang 2017] was found.

	Interphone (2010)	Interphone (App. 2) (2010)	Hardell (2013)	CERENAT (2014)
1640+ hours	1.40*	1.82*	1.75*	2.89* (896+ hrs)
10+ years	0.98	2.18*	1.79*	1.61

The Cerenat Case-Control Study was conducted in 4 areas of France from 2004 to 2006. 253 gliomas, 194 meningiomas, 892 matched controls. With cumulative call times larger than 896 hours, odds ratios were 2.89 (1.41, 5.93) for glioma and 2.57 (1.02, 6.44) for meningioma.

For *brain tumors*, cell phone users of 10 years or longer have a 20% increase in risk (when the cell phone is used on both sides of the head). For *ipsilateral* cell phone users (predominantly on one side of the head) of 10 years or longer, there is a 200%

	Hardell (2013)	Interphone (2010)	Combined
Glioma: overall	1.78*	0.84	1.22
Glioma: ≥1640 hours	2.94*	1.96*	2.29*
Acoustic neuroma: overall	1.78*	0.77	1.16
Acoustic neuroma: ≥1640 hours	3.10*	2.33*	2.55*

increased risk of brain tumor.

For *acoustic neuromas*, there is a 30% increased risk with cell phone use at ten years and longer, and a 240% ipsilateral increased risk. These numbers are based on the combined results of several studies (a meta-analysis).

Parotid gland tumors have been associated with cell phones, but only on the side of the head the phone is used [Sadetzki 2007; de Siqueira 2016].

Glioma patients with astrocytoma Grade IV showed a decreased survival associated with long-term use of mobile and cordless phones [Carlberg 2014].

A recent systematic review [Kathuria 2017] of brain tumor risk in long-term cell phone users varied, depending upon the

quality of the research study, with higher quality studies tending to yield greater risk estimates. For the five highest quality studies, the estimates ranged from a 21% increased risk to 2.6 times the risk of a non-cellphone user. For five lower quality studies, the estimates ranged from a 47% reduced risk to 5.1 times the risk of a non-cellphone user.

Here is a list of reviews on cellular phones and brain cancer:

Hardell, Carlberg (2013). Using the Hill viewpoints from 1965 for evaluating strengths of evidence of the risk for brain tumors associated with use of mobile and cordless phones.

<http://1.usa.gov/1jelT8p>

Morgan, Miller, Sasco, Davis (2015). Mobile phone radiation causes brain tumors and should be classified as a probable human carcinogen (2A) (Review). <http://1.usa.gov/1EqL1DF>

Myung, Ju, McDonnell, Lee, Kazinets, Cheng, Moskowitz (2009). Mobile phone use and risk of tumors: a meta-analysis.

<http://1.usa.gov/12wB0md>

IARC monographs on the evaluation of carcinogenic risks to humans. Volume 102: Non-ionizing radiation, Part 2: Radiofrequency electromagnetic fields. (2013).

<http://bit.ly/10oIE3o>

5.3.8.2. Thyroid Cancer

Epidemiological detection may be confused by changes in the

electromagnetic parameters of EMR, or to changes in the location of antennas. The telco industry has been very dynamic in updating the characteristics of

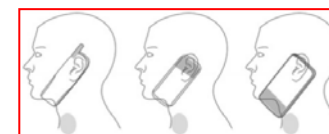
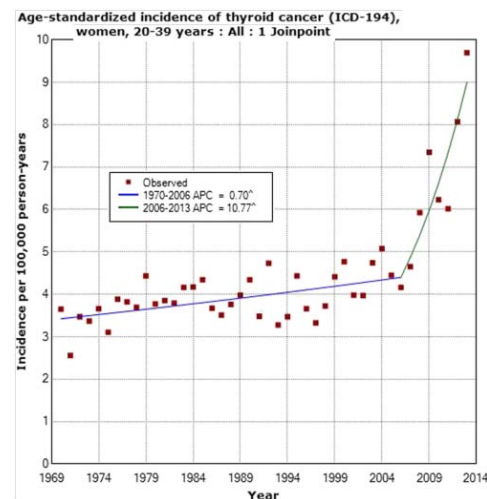

emitted signals over time (TDMA, CDMA, GSM, 3G, 4G, 5G). It has also changed the location of antennas (below), which have migrated from near the brain to near the thyroid gland for “smart phones”, coinciding with increases in thyroid cancers [Carlberg 2016; Baby 2017; Mortavazi 2009; Esmekaya 2010]. 3G can damage DNA and promote tumor growth at levels around 50 times lower (0.04-0.05 W / kg) than the standard for mobile phones i.e. 2 W/kg.

5.3.8.3. Breast Cancer

A case series of multifocal invasive breast cancer in four young women who regularly carried their smartphones directly against their breasts for up to 10 hours a day raises a possible association with exposures from cellular phones. The subjects developed tumors in areas of their breasts immediately underlying the phones. Pathology of all four cases shows striking similarity; all tumors are hormone-positive, low-intermediate grade, having an extensive intraductal component, and all tumors have near identical morphology. These cases raise awareness to the lack of safety data of prolonged direct contact with cellular phones [West 2013].

Exposure to GSM cell phone radiation for 4 hours altered ERa gene methylation, leading to detrimental epigenetic changes in ERa promoter methylation pattern relevant to colon cancer, but also involving epigenetics in EMR pathology [Mokarram 2017].

5.3.9. Nervous System

A graphic abstract of the literature on effects of EMR on the brain is available at
PHH21\Electromagnetism\Readings\Electromagnetic Radiation Brain Effects map Oscillatorium 2018.pdf.

5.3.9.1. Blood-Brain Barrier

In healthy tissues, there is no protein outside blood vessels, in the extracellular space.

The blood-brain barrier permeability is affected by sub-thermal EMR [Frey 1975], and the effect has repeatedly been confirmed [Persson 1997; Salford 2003; Poullietier de Gannes 2017] as penetration of albumin into brain cells.

But this evidence has been actively suppressed by the US military, and funding for further research denied.

Alan Frey, September 25, 2012: “For example, after my colleagues and I published in 1975 that exposure to very weak MW radiation opens the regulatory interface known as the blood brain barrier (bbb), a critical protection for the brain, the Brooks Air Force Base group selected a contractor to supposedly replicate our experiment. For 2 years, this contractor presented data at scientific conferences stating that MW radiation had no effect on the bbb. After much pressure from the scientific community, he finally revealed that he had not, in fact, replicated our work. We had injected dye into the femoral vein of lab rats after exposure to MWs and observed the dye in the brain within 5 minutes. The Brooks contractor had stuck a needle into the animals’ bellies and sprayed the

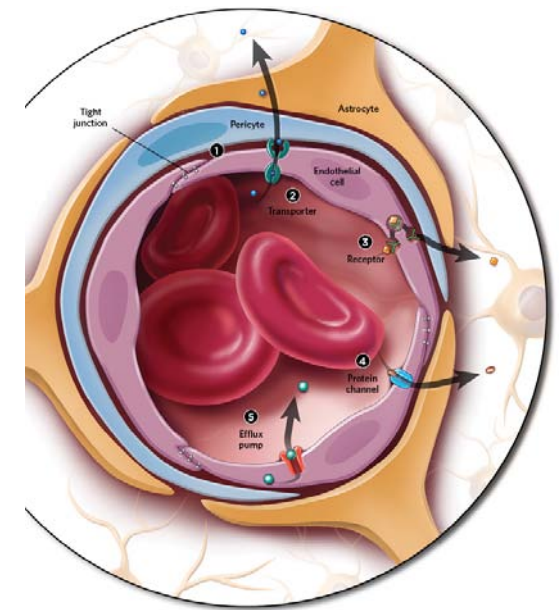

dye onto their intestines. Thus it is no surprise that when he looked at the brain 5 minutes later, he did not see any dye; the dye had yet to make it into the circulatory system.”

Salford: “The intense use of mobile phones, not least by youngsters, is a serious memento. A neuronal damage may not have immediately demonstrable consequences, even if repeated. It may, however, in the long run, result in reduced brain reserve capacity that might be unveiled by other later neuronal disease or even the wear and tear of ageing. We cannot exclude that after some decades of (often), daily use, a whole generation of users, may suffer negative effects such as autoimmune and neuro-degenerative diseases maybe already in their middle age”.

Whole-body power densities below 10 mW/kg (40 times less than the thermal standard) gives rise to more pronounced albumin leakage than higher but non-thermal levels. Such SAR-values (1 mW/kg) exist at a distance of more than one meter away from the mobile phone antenna, and at a distance of about 150–200 m from a base station. Further, when a mobile phone operating at 915 MHz is held 1.4 cm from the head, the very low SAR levels of 10 mW/kg exist in deep-lying parts of the human brain, such as the basal ganglia, and the power density of 1 mW/kg and less is absorbed in the thalamus bilaterally. The blood-brain barrier (BBB) plays a pivotal role in the healthy and diseased CNS [Knowland 2014].

Graphic displays of albumin extravasation in the brain of rats.
Salford [1994, 2003] below, Persson [1997] following.

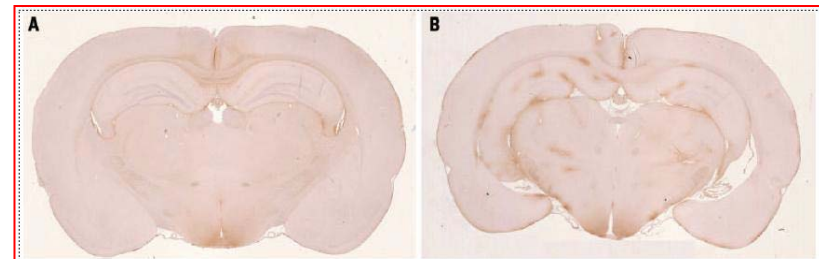
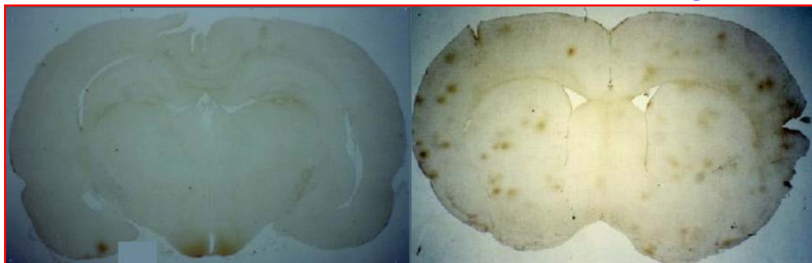

Figure 1. Cross-section of central parts of the brain of (A) an unexposed control rat and (B) an RF EMF-exposed rat, both stained for albumin, which appears brown. In (A), albumin is visible in the central inferior parts of the brain (the hypothalamus), which is a normal feature. In (B), albumin is visible in multiple small foci representing leakage from many vessels. Magnification, about $\times 3$.

Salford LG et al. Nerve Cell Damage...from GSM Mobile Phones. EHP 111:7, 881-883

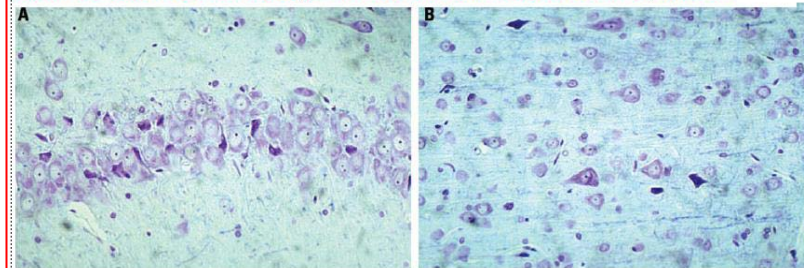

Figure 2. Photomicrograph of sections of brain from an RF EMF-exposed rat stained with cresyl violet. (A) Row of nerve cells in a section of the pyramidal cell band of the hippocampus; among the normal nerve cells (large cells) are interspersed black and shrunken nerve cells, so-called dark neurons. (B) The cortex, top left, of an RF EMF-exposed rat showing normal nerve cells (pale blue) intermingled with abnormal, black and shrunken “dark neurons” at all depths of the cortex, but least in the superficial upper layers. Magnification, $\times 160$.

5.3.9.2. Central Nervous System

The nervous system is vulnerable to metabolic inhibition by EMR [Saikhedkar 2014] because of its high metabolic rate, and dependence on oxygen (OXPHOS, Sanders 1985). Predictably, most of the evidence for brain damage is available from rats and mice.

Sub-thermal amygdala morphology changes in rats, with a decrease in healthy neuron numbers from apoptosis is coordinated with altered place preference [Narayanan 2018].
Vacuolization in brain tissue and the number and size of

vacuoles considerably increased during two months of EMR exposure to male Wistar rats. Cell phone EMR exposure induced significant hormonal and structural changes in adrenal gland and brain tissues [Shahabi 2018].

Histopathological analyses also confirmed significant deleterious alterations in the brain tissues of Wi-Fi-exposed animals together with DNA damage [Ibitayo 2017] as well as interference with microRNA expression [Dasdag 2015]. EMR disrupts cerebellar morphology and reduces the number of Purkinje cells in adolescent rats [Aslan 2017].

The density of the Synaptic Vesicles is significantly decreased in the presynaptic boutons of cortical neurons after EMR exposure [Mohammad 2017].

The eye is also vulnerable: eye cells recognize EMR as a stress factor, and in response, activate caspase-3 and p38MAPK gene expressions. These results confirm that EMR can cause cellular damage in rat ocular cells [Eker 2018].

Although exposures are not extreme, residence near mobile phone base stations is associated with a measurable risk at levels as low as 2,800 (40 m) to 7,520 $\mu\text{W}/\text{m}^2$ (400 m). The exposed group (n = 40), residing within a perimeter of 80 meters of mobile base stations, showed significantly ($p < 0.0001$) higher frequency of micronuclei (MN) when compared to the control group, residing at least 300 meters away from the mobile base stations. Analysis of various antioxidants in the plasma of exposed individuals revealed a significant attrition in glutathione (GSH) concentration ($p < 0.01$), activities of catalase (CAT) ($p < 0.001$) and superoxide dismutase (SOD) ($p < 0.001$) and rise in lipid peroxidation (LOO) when compared to controls. Multiple linear regression analyses revealed a significant association among reduced GSH concentration ($p < 0.05$), CAT ($p < 0.001$) and SOD ($p < 0.001$) activities and elevated MN frequency ($p < 0.001$) and

LOO ($p < 0.001$) with increasing EMR power density [Zothansiana 2017].

5.3.9.3. Radiowave Sickness

Nervous and cardiovascular system alterations and behavioral effects following human exposure to MW energy have been reported mostly in the East as “*radiowave sickness*” [Tiazhelova 1982]. The descriptions include fatigue, headache [Wang 2017], sleepiness, irritability, loss of appetite, memory difficulties, psychic changes [Chudnovskii 1979], unstable mood, hypochondriasis and anxiety. *The signs are usually reversible if exposure is discontinued.* Other frequently described manifestations are a set of cardiovascular changes [Lu 1992] including bradycardia (or occasional tachycardia), arterial hypertension (or hypotension) and changes in cardiac conduction. No serious cardiovascular disturbances have been described, however. This “*radiation sickness*” seems to manifest in the West recently as Electromagnetic Hypersensitivity (5.3.9.6).

There is substantial evidence that non-thermal EMR will affect the **electro-encephalogram** [Stocklin 1981]. Investigations in the influence of acute, low-level MW exposure on the cholinergic system of the rat brain showed that after repeated exposure, changes occur in the muscarinic cholinergic receptors, mediated by opioid and corticotropin-releasing factor (CRF).

Long-term evolution (LTE) wireless telecommunication systems are widely used globally, but also induce changes in human electroencephalograms at the power emission equivalent to the maximum emission from an LTE mobile phone. Exposure to LTE EMR reduced the spectral power and the inter-hemispheric coherence in the alpha and beta bands of the frontal and temporal brain regions. These findings were

also corroborated by functional magnetic resonant imaging [Yang 2016].

5.3.9.4. Electromagnetic Hypersensitivity

Despite physiological findings of inflammation, hypo-perfusion in the temporal lobes upon chemical exposure, a change in the permeability of the blood brain barrier specific to EHS and other findings [Bellepomme 2020], EHS remain marginalized and treated only by environmental physicians, who themselves are marginalized by mainstream medical “science” for their efforts [Gibson 2016].

The incidence of complaints from people suffering from EHS is on the rise. Possible symptoms include: headaches, fatigue, tinnitus, recurring infections, difficulties concentrating, memory loss, inexplicable unhappiness, dermatological symptoms, irritability or sleeplessness, heart problems, poor blood circulation, disorientation, nasal congestion, reduced libido, thyroid disorders, eye discomfort, tinnitus, increased

need to urinate, listlessness, capillary fragility, cold hands and feet, and stiff muscles.

These symptoms are worse in the vicinity of electrical appliances, transformers, mobile phone antennas and other sources of radiation [Kacprzyk 2020]. But sufferers display no symptoms when unexposed. It has been possible to demonstrate hypersensitivity in controlled tests [Rea 1991; McCarty 2011].



EHS sufferers experience a serious deterioration in their quality of life because of the physical symptoms and because their lives are disrupted by their need to avoid exposure. They have

13 year Jenny Fry, diagnosed with EHS, fought for two years simply so she could sit away from her classroom Wi-Fi router, because it gave her excruciating headaches. No action was taken by her teachers on her behalf, and at 15, Jenny took her life by suicide.

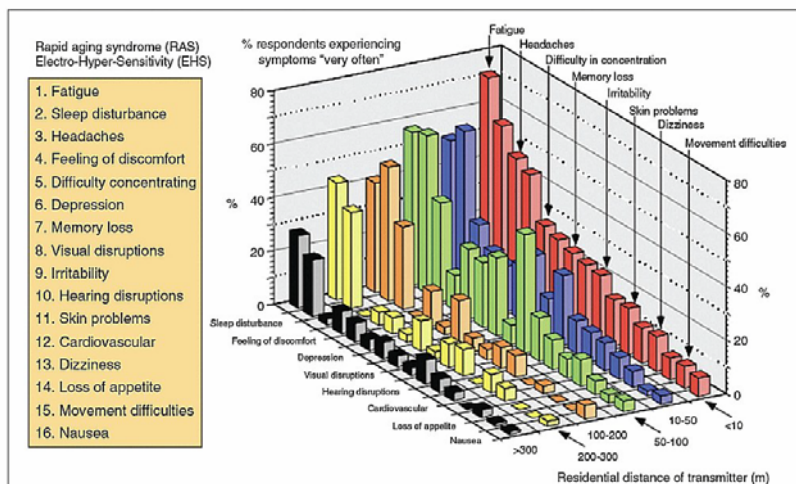

Figure 2. Symptoms experienced by people living near cellular phone base stations. Based on work by Santini et al. 2002, reproduced from Havas 2013.

to avoid almost all public facilities, and often even their own homes. Clinical work to assemble clinical criteria is ongoing. EHS is recognized as a functional impairment in Sweden, and Spain has recognized EHS as a permanent disability [Genius 2012]. Various Canadian governments recognize Environmental Hypersensitivity, although not necessarily EHS specifically [Canadian Human Rights Commission 2007]. The Austrian Medical Association’s EMR Working Group has developed guidelines for the diagnosis and treatment of what they call “EMR syndrome,” or health problems and illnesses related to EMR exposure. The guidelines suggest standard diagnostic tests, as well as 24-hour blood pressure monitoring, ECG, heart rate variability testing and measurement of EMR.

The exposure thresholds below are based on building biology standards.

Variable	Normal Limits	of Concern
AC Magnetic Fields	< 20 nT	> 400 nT
AC Electric Fields	< 0.3 V/m	> 10 V/m
EMR Radiation	< 1 $\mu\text{W}/\text{m}^2$	> 1000 $\mu\text{W}/\text{m}^2$

EMR Hypersensitivity is often connected to Chemical Hypersensitivity, and as the syndrome develops, subjects also become sensitive to more sources of electromagnetic radiation. Connection has also been made to head injuries and mold exposures [Heuser 2017], and EHS is associated with specific genetic variations [De Luca 2014].

About a third of occupational hygienist, occupational physicians and general practitioners in the Netherlands are consulted by patients attributing symptoms to EMR exposure. Many of these professionals consider a causal relationship between EMR and health complaints to some degree plausible, and their approach often also includes exposure reduction advice. The majority of these professionals feels insufficiently informed about EMR and health to deal with patients who attribute symptoms to EMR [Slotje 2016].

5.3.9.5. Memory

One of the most frequently reported effects of EMR is an impact on memory.

In Animals - rats

Experiments in Wistar rats at 900 and 2,100 MHz for 2 h/day over 1 or 10 weeks report effects on protein expression in the **hippocampus** [Gokcek-Sarac 2017]. One month exposure to cell phone radiation led to increases in apoptotic proteins (Bax, Acas-3) and a decrease in anti-apoptotic protein (Bcl-2) immunoreactivity, along with a decrease in the total granule and pyramidal cell count [Gevrek 2017]. At 160,000 $\mu\text{W}/\text{m}^2$, 2.45 GHz microwave radiation impairs learning, memory, and

hippocampal synaptic plasticity in the rat [Karimi 2018; Varghese 2017].

Sub-thermal 2450 MHz radiation induced cognitive behavioral deficit with concomitant loss in **mitochondrial** function. Mitochondria experienced oxidative stress and decrease in *matrix metalloproteinase*, which ultimately lead to loss of mitochondrial integrity [Pokorny 2017]. Mitochondrial stress, observed from increases in cytochrome-c, activated the expression of caspase-9 and caspase-3, indicating mitochondrial-linked apoptosis. EMR increased expression of hippocampal Ab and decreased cholinergic neurotransmission in the hippocampus, considered to be important factors for development of cognitive dysfunction [Gupta 2018]. GSM exposed Wistar rats animals also exhibit impairment of **inhibitory avoidance** [Ahmadi 2018].

From effects of pulsed 1800 MHz on amino acid neurotransmitters in 3 different areas of juvenile and young adult rat brain, it was concluded that the alterations in amino acid neurotransmitters of juvenile and young adult rats may underlie many of the neurological effects reported after EMR exposure including cognitive and memory impairment and sleep disorders. Some of these effects may persist for some time after stopping exposure [Ahmed 2018; Wang 2000].

In Animals - mice

In mice exposed to GSM 1800 MHz mobile phone radiation, hippocampal lipidome and **transcriptome** changes may explain brain proteome changes and memory deficits [Fragopoulou 2018]. Decreases in global DNA and histone methylation in the hippocampus involve epigenetics [Kumar 2021]. Mice also showed increase in the level of anxiety through GABA and aspartic acid after 4-week exposure to 1.8 GHz [Zhang 2017].

In Humans

A change in memory performance over one year in 439 adolescents was negatively associated with cumulative duration of wireless phone use and more strongly with EMR dose. This may indicate that EMR exposure affects memory performance [Schoeni 2015].

EMR affected brain functions such as figural memory in regions most exposed during mobile phone use over 1 year in a prospective study in 274 Swiss adolescents [Foerster 2018]. In a study of female medical students, it was concluded that a lack of attention and concentration may occur in subjects who talk on mobile phones for longer times, compared to those who use phones relatively less [Deniz 2017].

Significant impairment in Motor Screening Task and Spatial Working Memory was identified among the group of students who were exposed to high RF-EMF produced by mobile phone base station towers. High exposure to RF-EMF produced by MPBSTs was associated with delayed fine and gross motor skills, spatial working memory, and attention in school adolescents compared to students who were exposed to low RF-EMF [Ayoub 2018].

5.3.9.6. Behavior

EMR has persistent and long term effects on behavior and activity in mice [Broom 2019], acts as a stressor and induces anxiety-like behaviors with concomitant pathophysiological changes in EMR subjected rats [Gupta 2019]. Narayanan [2019] provides a review for rodents and Wallace [2019] for humans.

5.3.9.7. Alzheimer's Disease

A review has found that wireless radiation could increase the risk of Alzheimer's Disease, and cause other neurological

damage. The authors say 'we can conclude that the current exposure to microwaves during the use of cell phones is not safe for long-term exposure, despite the current scientific opinion.' They suggest exposure could injure the hippocampus, cause breaches of the blood-brain-barrier, and impair cognitive function [Zhang 2016]. Another review by Dasdag [2020].

5.3.9.8. Peripheral Nervous System

Connections are made with chronic diseases such as multiple sclerosis [Kostic 2013; Ohl 2016; Abbasi 2017], amyotrophic lateral sclerosis [Ahmed 2000; Kawamat, 2010; Gunnarsson 2018] and autism [Chauhau 2006; Haas 2010].

5.3.9.9. Protection of the CNS from EMR

There are many examples of experiments on the brain showing the deleterious effects of EMR [Tohidi 2020; Zielinski 2020; von Niederhausern 2019], and also many where administration of antioxidants such as vitamin E [Sanji 2020] reduced the deleterious impacts of EMR.

5.3.10. Immunity

Immune system suppression has been associated with "electrosmog" [Marshall 2017]. The human Vitamin-D receptor (VDR) and its ligand, 1,25-dihydroxyvitamin-D (1,25-D), are associated with many chronic inflammatory and autoimmune diseases. Structural instability of the activated VDR becomes apparent when observing hydrogen bond behavior. A case series of 64 patient-reported outcomes subsequent to use of a silver-threaded cap designed to protect the brain and brain stem from microwaves resulted in 90% reporting "definite" or "strong" changes in their disease symptoms. Effective control of environmental Electrosmog may not be useful only for the 3–5% reported EHSs in a

healthy population, but may be a successful therapy for some autoimmune diseases.

Combinations of two radiation frequencies (900 and 2,450 MHz) sub-thermally induced a decrease in phagocytic activity and an increase in inflammatory, cytoprotective, and cytotoxic responses in macrophages after continuous and combined exposure of multiple EMR signals in cultured cells [López-Furelos 2018].

In male albino rats, two reports of effects on serum iron parameters. Chronic exposure to mobile phone radiation of 30 min to 1 hour per day for 5 months increases hepcidin level with subsequent impairment of iron parameters, in addition to negatively affecting both unsaturated iron binding capacity and total iron binding capacity [El-Maleky 2018]. Exposure to EMR created by mobile phones affected unsaturated iron binding capacity and total iron binding capacity negatively [Çetkin 2017].

Chiang [1986] found that environmental EMR levels (100,000-400,000 $\mu\text{W}/\text{m}^2$) slightly influence central nervous system and immune functions in children. 1000 subjects going to school in locations near AM broadcast antennas or radar installations had altered neutrophil phagocytosis; incidence of bradycardia was increased at high exposures. Exposed subjects performed more poorly on visual reaction time and short-term memory tests.

5.3.11. Reproduction, Growth and Development

5.3.11.1. Reproduction

Singh [2020] provides a review and Santini [2018] a focus on mitochondrial damage as important in both male and female reproduction.

EMR alters reproductive organ weights and endocrine hormones, male germ cells, sperm motility, the estrous cycle, fetal and embryonic development, and pregnancy success. The effects differ according to field strength, frequency and wave type, and duration of exposure [Gye 2012; Asghari 2016; Sepehrimanesh 2016, 2017; Altun 2018].

5.3.11.2. Testes and Sperm

A significant decline in sperm counts between 1973 and 2011, driven by a 50–60% decline among men unselected by fertility from North America, Europe, Australia and New Zealand needs an urgent explanation [Levine 2017].

It is quite possible that chronic exposures to low levels of radiation contribute to reduced fertility in humans [Kesari 2018; Yahyazadeh 2018; Jaffar 2019; Adams 2014; Liu 2014].

In Animals - rats

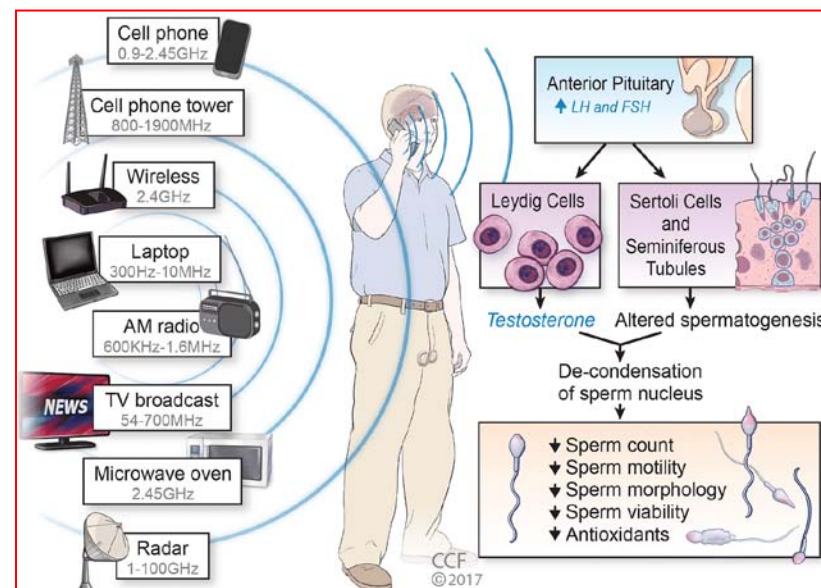

In rats, testicular ultrastructure is reported to be altered by 900 MHz radiation [Gao 2016], and 28 days of 1,460,000 $\mu\text{W}/\text{m}^2$ change reproductive parameters in rats [Narayanan 2018]. Effects on interleukin-6 and C-reactive protein, as well as on necrosis and spermatogenesis were found at levels of about 500,000 $\mu\text{W}/\text{m}^2$ under only 30 1-hour exposures [Bilgici 2018]. Spermatogenesis was altered when rats were daily exposed and placed for 1 month at various distances from cell phones [Oh 2018]. Involvement of steroidogenesis and inflammation in Leydig cells is observed [Azimadeh 2019].

In Animals - mice

In mice, oxidative stress and DNA damage in germ cells and altered cell cycle progression leading to low sperm count occurred with 200 h spread over 35 days at 50,000 to 500,000 $\mu\text{W}/\text{m}^2$ [Pandey 2016]. Exposure to mobile phones for 120 days, 3 h/day, showed oxidative stress leading to apoptosis of testicular cells and impaired testicular function. A number of metabolic and genetic elements detailed the effect [Shahin 2018]. Involvement of ROS is confirmed [Houston 2019].

In Humans

In a group of 31 adult males exposed for a mean of 8 years to levels of 100,000 to 1,000,000 $\mu\text{W}/\text{m}^2$ (“athermal” levels), statistically significant decreases in the number of sperm per ml of semen, percent motile sperm in the ejaculate, and percent normal sperm were observed [Lancranjan, 1975]. Such effects can be explained by alterations in ATP production by high frequency radiation [Perchec 1995], supported by physiological studies pointing to the oxidative phosphorylation chain, specifically Complex III, as the source of the problem [Houston, 2016, 2018], and linking fertility effects to interference with ATP Synthase. This work also shows a fading in and out of DNA fragmentation, according to exposure time.

EMR from Wi-Fi connections in laptop computers decreases human sperm motility and increases sperm DNA fragmentation [Avendano 2012], and alters sperm quality [Mortazavi 2010; Hamada 2011].

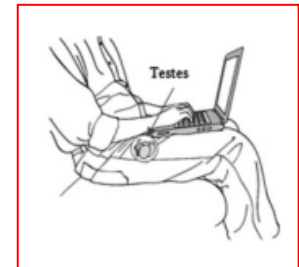

Semen incubated near a 3G WiFi modem for 50 minutes shows a significant decrease in sperm motility and velocity, especially in non-progressive motile sperms [Kamali 2017].

In 159 men, normal sperm morphology was inversely associated with cell phone use of more than 1 hour, and directly to distance from cell phone towers [Al-Bayyari 2017].

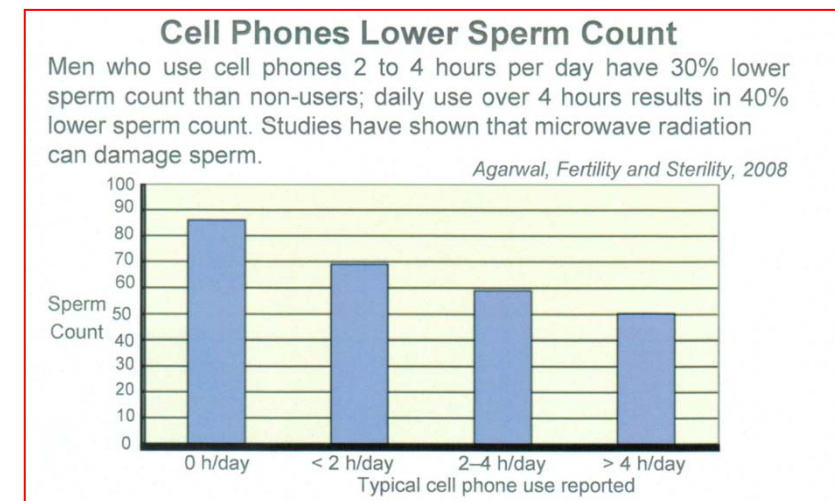

5.3.11.3. Implantation, Growth and Development

In Animals - mice

Mice display reduced birth weight associated with non-thermal levels of radiation (2.45 GHz) exposure [Marcickiewicz 1986].

Alterations in the developing mice brain after intrauterine 10 GHz microwave exposure from different gestation days (0.25 and 11.25) till term involved reduction in the brain and body weight of MW-exposed group at 3 weeks of age: increased level of lipid peroxidation, decreased level of glutathione and protein after exposure. Moreover, changes in cyto-architecture of hippocampus and cerebellum of the brain and reduction in Purkinje cell number were observed. The severity of damage in neonatal mice brain was much higher, when exposure started from 0.25 day of gestation compared to 11.25 days of gestation [Sharma 2016, 2017].

900-1800 MHz for 2h/day for 20 days induced oxidative stress in tissues of mouse dams and their offspring [Bahreyni Tossi 2017].

Cell-phone radiation affects development of mice embryos as well as the number of newborns and pregnancy duration, which might be a significant cause of reproductive failure. It induced an increase in the number of dead embryos, and a decrease in the number of newborn mice [Fatehi 2018].

915 MHz radiofrequency radiation affected mice fetus weight, length and tissue growth parameters [Alimohammadi 2018].

Mobile phone (1800MHz) radiation impairs female reproduction in mice through stress-induced inhibition of ovarian & uterine activity [Shahin 2017, 2018].

In Animals - rats

Developing rats exposed to Wi-Fi showed oxidative stress in the brain and liver, the result of reduced glutathione peroxidase, glutathione and antioxidant vitamin concentrations. Moreover, the brain seemed to be more sensitive to oxidative injury compared to the liver during the development of newborns [Celik 2016].

Maternal exposure to WiFi radiofrequencies led to various adverse neurological effects in offspring by affecting

neurodevelopment, cerebral stress equilibrium and cholinesterase activity [Othman 2017, 2017a].

1880–1900 MHz (DECT) base station radiation at an average electric field intensity of 3.7 V/m, 12 h/day, caused heart rate increase in the embryos on the 17th day of pregnancy in Wistar rats. In newborns, pyramidal cell loss and glial fibrillary acidic protein (GFAP) over-expression were detected in the CA4 region of the hippocampus. Changes in the integrity of the brain in the 22-day old pups could be related to developmental behavioral changes during the fetal period [Stasinopoulou, 2016]. In rats, maternal immune activation increased the developmental EMR exposure-induced long-term neurobiological impairments [Petitdant 2018].

900 MHz radiofrequency mobile phone radiation exposure for 10 h each day during chick embryogenesis impaired social behaviors after hatching, and possibly induced cerebellar retardation [Zhou 2016].

The chronic exposure of chick embryo liver to EMR emitted from 2G and 3G cell phones resulted in various structural changes and DNA damage. The changes were more pronounced in the 3G experimental group [D’Silva 2017].

100 MHz EMRs affect Zebra Fish embryonic development, from 24 to 72h post-fertilization in all the analyzed pathways. At 48 h post-fertilization, reduced growth, increased transcription of oxidative stress genes, onset of apoptotic/autophagic processes and a modification in cholesterol metabolism were detected. Zebra Fish embryos faced stress induced by EMR radiation by triggering detoxification mechanisms and at 72 h they partially recovered from stress, reaching at hatching time in a comparable way with respect to the control group [Piccinetti 2018].

In Humans

There have been reports from the East of congenital abnormalities in women working in EMR. At the termination of pregnancy, MW heating has been used to relieve the pain of uterine contractions *during labor*. The analgesic effect was found helpful in 2000 patients [Daels 1976], and no evidence of problems was uncovered in a one year follow-up. On the other hand, five cases of inborn defects in offspring have been observed elsewhere in women exposed during the *early* stages of pregnancy to short-wave diathermy.

Pregnancies of mothers reporting MW use 6 months prior to the pregnancy or during the first trimester were more likely to result in miscarriage (OR=1.28, CI 1.02-1.59). The odds ratio increased with increasing level of exposure [Ouellet-Hellstrom 1993]. The odds ratio in the highest exposure group (20+ exposures per month) was 1.59. The risk of miscarriage was not associated with reported use of short-wave diathermy equipment (OR=1.07, CI 0.91-1.24).

From 461 mother-child pairs, excessive mobile phone use during pregnancy may be a risk factor for lower birth weight and a high rate of infant emergency transport [Lu 2017].

Following detection of biochemical changes in the infants of mothers using mobile phones, the suggestion to pregnant women is to avoid mobile phones during pregnancy [Bektas 2018], and increased risk for behavioral problems, particularly hyperactivity/inattention problems has been associated with cell phone use [Birks 2017].

Patterns of lower mean cognition scores among children in relation to high frequency maternal pre-natal cell phone use

[Sudan 2018] as well as offspring speech problems [Zarei 2019].

Many of the reports above use high, but non-thermal, levels of radiation over relatively short periods of time. These are thought to represent life-long exposures at much lower levels. Rapidly developing tissues may have increased vulnerability to EMR. According to Soviet research, the following health hazards are likely to be faced by children who use mobile phones in the near future: disruption of memory, decline of attention, diminishing learning and cognitive abilities, increased irritability, sleep problems, increase in sensitivity to stress, increased epileptic readiness.

Because of the link between malformations and EMR exposures, some investigators have suggested that the exposure allowed for pregnant workers be reduced to that specified for the general public.

5.4. Applications of Radio-Frequencies and Microwaves

In specific occupational situations, exposures can exceed 10,000,000 $\mu\text{W}/\text{m}^2$, the thermal occupational limit at 70 MHz:

- ✚ maintenance crews near broadcast towers and high power radars,
- ✚ workers using dielectric and induction heaters,
- ✚ operators of electro-surgical units (surgical electro-cautery),
- ✚ operators of EMR diathermy machines for the treatment of cancer),
- ✚ operators of Magnetic Resonance Imaging equipment,
- ✚ personnel working near antennas of mobile communications equipment,
- ✚ welders using electric arcs,

✚ workers extensively using EMR communications.

However, given the range of EMR intensities that affect biological systems, the whole population is “over-exposed”. The relatively flat or complex dose-response (over intensity and frequency) of many of the effects weakens the possibility that occupational investigations will yield clues to protect the general population.

WIDE-SPREAD EMR APPLICATIONS

Dielectric Heaters: seal and emboss plastics, cure glues, resins, particle boards and panels, bake sand cores, mold appliance covers and auto parts, heat paper products.

Induction Heaters: deep hardening, forging, welding, soft soldering, brazing, annealing, tempering metals and semi-conductors purification.

Broadcasting: AM, FM, VHF.

Communications: CB radios, walkie-talkies, cell phones.

Propagation of EMR signals is not effective through normal wiring used for power connections. While lower frequency signals can be transmitted from the instruments to the application point through short coaxial cables, high frequency signals (above 1 GHz) require wave guides for minimal attenuation. Most of this EMR energy is intended for radiating antennas, either omnidirectional (straight vertical antenna), dipoles or focused (parabolic antennas). In other cases, the

energy is connected to specialized electrodes or radiators for

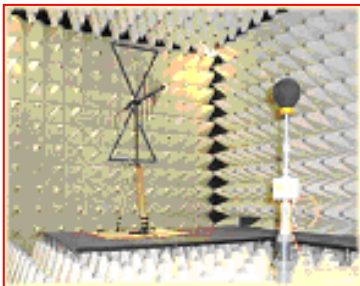

application to the body (diathermy) or to workpieces.⁴

EMR energy radiating from broadcast antennas can be studied in specially-designed rooms. As is the case for acoustic waves, reflections of EMR waves from boundaries will interfere with “free-field” measurements. So, anechoic rooms exist for this purpose. Measurements are illustrated above (antenna at left, field probe at right).

INDUSTRIES USING EMR

Mining and Metallurgy: desulphurizing coal.

Metal Working: processing foundry cores, drying casting molds, drying pastes and washes, slip casting.

Chemicals: preheating and vulcanizing rubber, processing polymers, devulcanizing rubber.

Wood and Paper: curing wood composites, drying paper, film, inks.

Food and Beverage: thawing and drying pasta, noodles, biscuits, onions, cooking meat, vacuum drying, baking, sterilizing, pasteurizing, freeze drying.

Clothing and Textiles: dye fixation, drying yarns and leather.

Telecommunications: satellites, MW relay communications, atmospheric studies, cellular phones, UHF and digital TV.

Health Care: diathermy.

Defense: location finding, radar (air, marine and traffic control).

5.4.1. Heating using EMR

Devices for heating will have the following components: a high frequency power source supplying the energy used for heating, wires or cables to carry that energy from the source to the

⁴ Radio frequency and microwave energies needed in various applications are generated by the electrical oscillation of transistors (lower frequency and power applications) or of gas-discharge tubes (higher frequency and power applications).

object to be heated, and electrodes-dye-applicator to interface with the object to be heated. In the case of ovens or cavities, there are no electrodes: the object to be heated is placed in an enclosure within which a field capable of heating is established.

5.4.1.1. Ovens

Frequencies of **915 MHz** (formerly) and **2450 MHz** are used for heating in industry, commerce and the home. In ovens, a *magnetron* (shown below) is used to establish a high frequency electric field inside the oven cavity, where objects to be heated are placed.

In the magnetron, electrons are emitted from a negative central terminal (cathode, -). A cylindrical anode (+) surrounding the cathode attracts the electrons which, instead of traveling in a straight line, are forced by permanent magnets to take a circular path. As they pass by resonating cavities (8 holes in the picture), they generate a pulsating field, or EMR, much as air vibrates when air is blown across the opening of a bottle. 500 to 1000 W of RF energy is generated in the 2.4- to 2.5-GHz range. Magnetrons may be superseded by power transistors using 32 V, rather than the high voltages needed by magnetrons.

Leakage from microwave oven doors was limited by connecting the interior of the oven to a door seal forming an input transmission line ended with a short circuit, a quarter wavelength away.

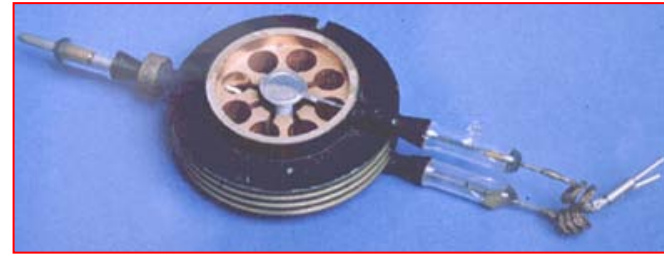

Magnetron.

Cathode at center is surrounded with anode resonating cavities.

Uniform world regulations for ovens specify 10,000,000 $\mu\text{W}/\text{m}^2$ at 5 cm from the outer surface for new units, and 50,000,000 $\mu\text{W}/\text{m}^2$ for used ones. The best protection is distance: for 50,000,000 $\mu\text{W}/\text{m}^2$ at 5 cm, the fall is to 150,000 $\mu\text{W}/\text{m}^2$ at 30 cm and 100,000 $\mu\text{W}/\text{m}^2$ at 1 m. Therefore, knowledge of operator position is very important in assessing exposure [Plets 2015].⁵

5.4.1.2. Dielectric Heaters

Dielectric heaters, a different category of devices, use a die (electrodes) to apply the 3 to 70 MHz (normally **13.56, 27.12 or 40.68 MHz** - this last frequency is near the value of *human resonant absorption*) electric fields to *melt, heat or cure plastic, glue or rubber*.⁶ It is estimated that 20,000 units are operating in the US. The mechanism of heat production here is in the dielectric relaxation of dipoles, which increases with frequency as well as with the square of the applied voltage.

⁵ For more details on regulations regarding microwave ovens, consult CSA standard C22.2 No. 150.

⁶ The process started replacing steam heating for the purpose of vulcanization around 1945.

In the color figure at right, an enclosed dielectric heater slides work parts through slots, which removes most operator exposure.

Problem 49. A EMR dryer in a paper diaper plant radiates a power of 90 W at 40.68 MHz. Assuming a hemi-spherical repartition of the irradiated energy, is the operator, who is placed two meters away on an insulated companionway within acceptable limits of exposure?

Dielectric Heater

Worker exposure to EMR radiation from a dielectric heater used in a waterbed plant was observed to exceed the ANSI occupational exposure guideline. A special shield was designed to protect the worker, which still allowed for an opening to introduce the product into the press and perform the sealing operation. Measurements were made before and after shield installation to control its effectiveness. The operators' exposures were reduced by the following average factors: E-field strength, 200 times; H-field strength, 10 times; foot current, 4.3 times.

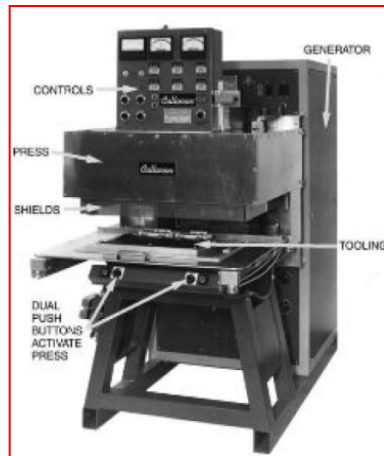

5.4.1.3. Induction Heating and Welding

A familiar induction heater is an induction *cooker*, which uses the heat losses associated with a 27 kHz alternating magnetic field to fire a magnetic pot placed above an induction coil. This does not work with cooking vessels made from non-magnetic materials (e.g., aluminum or glass). Only the vessel used for cooking is heated, which makes

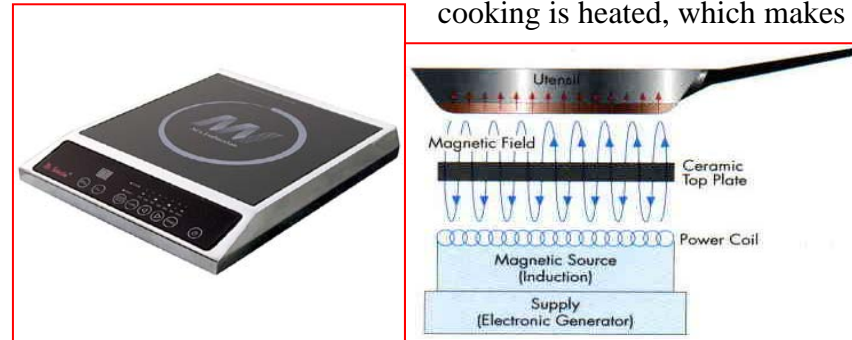

it slightly more efficient, and magnetic field control allows instantaneous adjustment of heating. People with implanted pacemakers would be well-inspired to stay away from such appliances [Hirose 2005].

Industrial induction heaters operate between 60 Hz and 30 MHz, usually with large power outputs. An estimated 60,000 low frequency (60 Hz - 8 MHz) induction heaters are used (and have been for approximately 40 years) in 20,500 US industries by 111,100 workers for metal product heating or melting, heating and drawing of optical fibers, zone refining, plasma torching, and crystal growth. These magnetic devices are applicable to conductive substances such as metals and crystals. The ability to heat by induction is technologically precious in cases where extremely pure materials must be obtained. 10% of the units are fully automated, 25% require limited human operation, the rest involving close supervision.

One important heating application is “float-zone” refining of semiconductors. In this case, a rod of silicon inserted within a coil is moved longitudinally and cyclically, such that the material melts and re-crystallizes. Repetition of this crystallization procedure pushes impurities to the ends of the rod, resulting in silicon of high purity that can later be doped for semi-conductor applications. Since power levels are very high with large-diameter rods (65-mm diameter), the efficiency of the heating process is a concern. One key parameter is the frequency of the current in the induction coil. Frequencies lower than 500 kHz produce undesirable surface melting characteristics, while higher frequencies increase arcing. The suitable range appears to be between 2 and 3 MHz.



Typical exposures for operators of induction heaters operating at frequencies between 50 Hz and 10 kHz range from 1 to 6 mT and exposures for induction heaters operating at frequencies between 100 kHz and 10 MHz range from 0.7 to 10.7 μ T.

A model illustrated on the next page produces a longitudinal seam in a metallic pipe through EMR induction (heating is helped by the *proximity and skin effect*). The operator is usually 0.5 to 1 m from the coil during operation, which is usually intermittent (2-60 seconds “on”). The magnetic fields can be extremely high in the case of low-frequency heaters.

Since the thermal exposure standards were developed using research assuming plane EMR waves, rather than magnetic fields, the assessment of the health effects from such devices is uncertain.

Problem 50. Three months ago, you have determined that the power density exposure limit of a worker operating a 66 kW, 50 MHz induction welder was exceeded by a factor of 10. The management offers to modify the existing machine by increasing the frequency to 1.5 GHz, increasing the power to 100 kW and increasing the distance between machine and operator by a factor of 2. Will these alterations in all likelihood result in the thermal standards being respected? Explain why.

Problem 51. You are in the far-field of an EMR source (an industrial welder) which has recently been upgraded, accompanied by your technician. You have a monitor which measures the electric field. You know that the upgrade on the machine increased its power by increasing the current used by it and the magnetic field it radiates. Your technician mentions that it will not be possible to sense that increased power since the monitor measures the electric field only. Is he right? Why?

Problem 52. You are studying the irradiation pattern of an EM welder functioning at a frequency of 70 MHz. The manufacturer has provided you with a contour map which shows the EM impedance of the irradiation near-field around the machine. Consulting this chart, you find that at the operator’s position, the EM space impedance is 150 ohms. Your detailed measurements show that at the operator’s position, which is in the near field, the power density is exactly 2 W/m². What is the ratio between the electric and magnetic fields at the operator’s position? Using plane wave assumptions, what would the electric and magnetic fields be at the operator’s position?

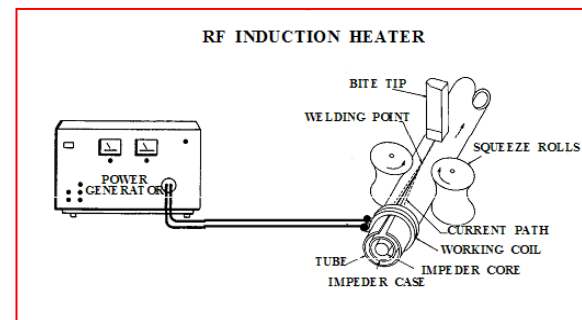

The system uses EMR energy and induction coil to produce seamless pipes or tubes

5.4.2. Damage due to Heat

Temperature increases from diverse sources may induce, beyond burns, chromosomal alterations, mutagenesis, virus activation and inactivation, as well as behavioral and immunological reactions. Temperatures above 39.3 Celsius, which can occur during a very hot bath, are dangerous to fetuses.

Chronic manifestations of health effects are more difficult to investigate than short-term effects, allowing the thermal hypothesis to survive for a long time. But EMR heating differs fundamentally from heating by conduction. The penetration depth is typically greater, hot spots beyond the surface may occur, and heating may be much more rapid. *C. Elegans* subjected to temperature rises begin producing heat-shock proteins at 27°C from pure heat, but at 24°C with a cell phone MW source [de Pomerai 2000].

5.4.2.1. Burns

There are distinctive differences between EMR burns and conventional ones. EMR heating is often deeper, and not uniformly absorbed (hot spots), more stress being placed on tissues with poor circulation: lens of the eye, gall bladder, gastro-intestinal tract, testes. Metallic implants can cause localized heating. Bypassing the pain endings may *delay sensation*. There may be a delay in the appearance of superficial and deep burns by as much as 6 days following exposure [Budd 1985]. Skin lesions show a considerably thickened affected area comparable to fourth degree burns, minimal inflammation, and absence of pain. Intense irradiation may result in denervation and irreversible blood stasis, followed by tissue necrosis and mummification.

5.4.2.2. Acute Heat

Generally, physiological responses are acutely observed in animals when radiation is applied at a rate which equals its basal metabolic rate.

During hard work, central temperatures may rise to 40-41°C for short periods. A rise in temperature to 42°C causes a two to three-fold increase in pulse rate, oxygen consumption, etc.⁷ This is the tolerable long-term limit. In mammals, deep body temperatures above 42°C lead rapidly to irreversible damage, and irrecoverable hyperthermia. The central nervous system ceases to function at 44-45°C, and the heart stops beating at 48°C. The short-term temperature lethal to human tissues is about 49°C.

5.4.2.3. Chronic Heat

When the rate of energy input is chronically maintained at twice the animal's metabolic rate, "significant" physiological adaptation develops.

Dogs exposed to 6 W/kg of MWs take 60 minutes on the first trial to show a rectal heat rise of 1.5 K. On the 34th trial, the time necessary to achieve the same temperature rise becomes 220 minutes. Dogs have been placed under additional thermal loads of up to 0.8 W/kg for periods of up to 13 months, without *apparent* ill effects. When regions repeatedly challenged by heat stresses are denervated, no adaptation is measured.

⁷ Abramson [1957, 1960] found that localized heat results in increased local circulation and oxygen uptake, up to twice the control levels. The response extends into the post-exposure period for an average of approximately 30 minutes. At higher exposure, vasospasm and decrease in blood circulation occur. The sodium clearance in muscle is greatly increased during exposure.

5.4.2.4. Cataracts

Knowledge of “*glass-blower’s cataract*”, and the fact that certain parts of the body, specifically the lens of the eye and the testes, are relatively poorly vascularized (and therefore have limited capacity to diffuse heat) incited investigations of the effects of MW heat on the **lens of the eye**. Since high frequency EMR was known to heat tissue (diathermy was established as a medical treatment early in MW history), work was carried out on cataracts and MW radiation using epidemiology, in vitro assays, and in vivo experiments, mostly on rabbits and monkeys.

In 1948, researchers confirmed the first deleterious effect resulting from MW exposure: cataract formation in dogs [Daily 1948]. It was realized that MWs could damage biological tissues by heating. Reports of human occurrence of MW-induced cataracts have been limited, possibly confined to the early period of uncontrolled, pre-thermal-standard MW exposures.

Early laboratory tests showed that rabbits given one high power dose of MWs began to develop cataract within three days, while animals receiving several lower power doses developed cataracts as long as forty-two days later [Richardson 1948].

In vitro studies of isolated murine lenses exposed to continuous and pulsed MWs have shown sometimes surprising results. Lenses kept at 37 and 39°C, when exposed to significant SAR, were found to have marked pathologic changes, as evaluated by scanning electron microscopy. Stewart-De Haan suggested in 1983 that *in the absence of temperature rise*, the effect of the EMR in itself is equivalent to a 10°C elevation in temperature. The same authors report cumulative damage from non-thermal

pulsed radiation (10 millisecond pulses). Increasing duration and dose rate increased depth of damage.

These reports are compatible with many others which indicate lower thresholds for a variety of effects when irradiation is pulsed rather than continuous. Short-term *in vivo* exposures have failed to show cataracts in the absence of temperature rises, however.

The threshold for the short-term induction of an opacity of the lens far exceeds the lethal whole-body exposure level. Therefore, likely scenarios for a short-term cataract must include non-uniform exposure. From experiments conducted on New Zealand white rabbits, the cataract power density threshold for 30 minute exposures at 2.45 GHz is 2,850,000,000 $\mu\text{W}/\text{m}^2$ and 15.3 W/kg. Acute lens damage probably could not occur in humans without associated facial burns. The short-term potential of MWs to produce cataracts varies with frequency, the most effective frequencies being in the range 1-10 GHz.

MWs may also increase the ability of alloxan and galactose to cause cataracts, and may speed up their development in diabetes. It should also be noted that combination of MWs and drugs taken for glaucoma such as pilocarpine and timolol maleate increase risk to the cornea’s epithelium [CCOH 1989].

At frequencies above 10 GHz, the first permanent eye damage is to the cornea, the outermost layer of the eye. At 35 GHz and higher frequencies, this damage threshold could be as low as 300,000,000 $\mu\text{W}/\text{m}^2$ for 1 hour.

Pulsed MWs are probably more bio-active for the same integrated dose than continuous MWs. Recent work on the sensitivity of the cornea [Kues 1992] and of the retina of the eye to pulsed MW radiation is giving indications of non-

thermal interactions, as well as of a non-dielectric mechanism acting between the applied fields and melanin [Osiander 1995]. In as far as chronic lens damage is concerned, there is the possibility of a lesion from MW exposure, *capsular cataract* [Zaret 1977]. Lens imperfections increase considerably with age, even during childhood. By age 50, most unexposed subjects show some type of damage.

In conclusion, the success of thermal rise in explaining short term cataractogenesis in animals should not make us blind (!) to other mechanisms that may be insignificant in acute exposures, but that may take increased importance in chronic exposures.

5.4.3. Electromagnetic Detectors

5.4.3.1. Metal Detectors

They are used in airports and prisons for security purposes. See tables below.

Exposures from walk-through metal detectors

Metal detector	Peak magnetic flux density (μT)	Exposure quotient
1	94	69%
2	105	40%

5.4.3.2. Identification (ID) Equipment

They consist of a source which produces an EMR signal emitted by an antenna. If a tag (active or passive) is within range, a resonating signal is emitted by the tag, which is detected by a receiving antenna. This is also how you get ID card access to restricted buildings. A passive 96-bit chip and antenna mounted on a substrate costs from 7 to 15 US cents.

Magnetic flux densities around RF ID equipment.

Measured values are italicised where the reference level was exceeded

Device	Frequency (kHz)	Reference level (μT)	Distance (cm)	Magnetic flux density (μT)
Card reader	120	17	7.5 12	20 10
Antenna	120	17	7.5	10
Antenna	134	15	2.5 5	25 7
Antenna	154	13	2.5 5 10	15.0 5.3 1.2
Card reader	4900	0.41	5 10 20	8.4 2.1 0.3

5.4.3.3. Electronic Article Surveillance (EAS)



To prevent theft from shops and libraries, tags (1 to 5 US cents), a detector, and a de-activation unit. A



broad range of frequencies (AM 58 kHz) can be used to detect a tag within a specific volume.

5.4.3.4. Full-Body Scanners



Security techniques at airports are chemical-detecting swabs, explosive-detecting puffer machines, drug-sniffing dogs, and full-body scanners working either at millimeter-wave (~20 GHz) or X-ray frequencies (backscatter machines, 30 PHz to 30 EHz). A **millimeter-wave imaging scanner** looks like a round phone booth. Two 2 m long beams of millimeter waves scan the body from

head to toe. These waves pass through fabric, but they reflect

off the water in our skin and in liquids that people might be trying to sneak onboard planes, detecting threats that metal detectors don't catch. A scan takes about 5 seconds. It is stated that "it uses 10,000 times less power than a cell phone ($59.7 \mu\text{W}/\text{m}^2$ for millimeter wave technology compared to $375,000,000 \mu\text{W}/\text{m}^2$ for a cell phone)", but there is no statement on SAR at the skin surface. Perhaps more importantly, such misleading statements assume that all effects are determined by heat alone, ignoring all non-thermal phenomena.

Backscatter devices employ X-rays and produce images that are more detailed and clearer than those of millimeter-wave machines. The ionizing radiation delivered by the system is said to be comparable to spending two minutes in an airplane at 30,000 feet (0.003 millirem for 2 backscatter scans compared to 0.0552 millirem for two minutes of flight).

5.4.3.5. Radar

Radar ("Radio And Detection And Ranging") is a military invention [Buderi 1996].⁸ A radar operates by transmitting a pulse of EMR energy, and waiting to receive energy reflected back from an object illuminated by the pulse. The radar interprets the time interval between transmission and return as a measure of the distance of the object. Some radars are designed to track ships, planes or missiles, while others detect weather patterns such as tornadoes, microbursts, wind shear and gust fronts. If the radar beam is concentrated in a narrow

⁸ In March 1935, the only instrument available on Royal Navy ships for detection of aircraft was a pair of binoculars of magnification $\times 7$. In late 1936, the first experimental set was fitted to an old minesweeper, which led to detection of aircraft 100 km away by the beginning of the war. The ship's bridge had traditionally been the place from which the captain fought battles, but by the end of the war, electronic technology had gained such influence that the bridge was rapidly superseded by the information center in the bowels of the ship [Howse, 1993].

beam, this permits greater certainty regarding the direction of the object detected, and also allows greater rejection of the environment's EMR noise. An antenna that is many wavelengths in diameter produces a pencil beam, and can select incoming radiation from a very specific direction. This is why large antennas may be needed at times to get the strength of focus and gain necessary at a given wavelength.

Modern-day ground-based radars (typically 1 to 9 GHz, up to 150 kW), may have fixed ("tracking radar") or rotating ("acquisition radar") antennas. Rotating antennas tend to reduce the local radiation exposure. Tracking radars tend to produce more exposure, and are usually located in remote areas. At 800 m, these systems can produce average power density levels of $100,000,000$ to $1,000,000,000 \mu\text{W}/\text{m}^2$.

In a survey of aircraft weather radars (20-100 kW, 5-10 GHz), average power densities of $1,000,000 \mu\text{W}/\text{m}^2$ but peak values of $1,700,000,000 \mu\text{W}/\text{m}^2$ were found in **cockpits**. Average power values in cockpits did not exceed $2,000,000 \mu\text{W}/\text{m}^2$ but **if the units were left operating while the plane was on the ground, passengers in waiting rooms could be exposed to as much as $10,000,000 \mu\text{W}/\text{m}^2$.**

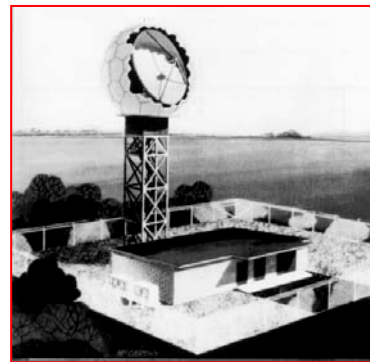

Terminal Doppler Weather Radar

Most of the "philosophy" surrounding radar exposure takes into account average power, because this value is about *100 times less than the peak power*, due to the scanning of the rotating antenna, and the burst-type emission signal. **The decision to focus on average**

power is only as good as the hypothesis that heat is the only deleterious agent.

Problem 54. A radar operates at an average power level of 20 W. Its pulse width is 1 μ sec and the pulse repetition frequency is 1000/sec. Calculate (a) the duty cycle, (b) the peak power.

Russian researchers [Soldatchenkov 1982] have experimented on rats at civil navigational radar (~ 1 GHz) power densities of 1 million, 5 million and 25 million μ W/m². Transient exposure simulating a rotating antenna was applied for 4 months. Significant changes were detected in the animals. The results suggest that limits should be improved to protect civilian populations living near the radar facilities.

Further Russian studies [Dumansky 1982] using the parameters of weather radars (1-10 GHz) at power densities of 50,000 to 1,150,000 μ W/m² were conducted on rats. Higher exposures had appreciable effects on the threshold of galvanic skin response, physical endurance, reflex latency as well as on biochemical parameters.

Planning of a US military radar station operating at 440 MHz involved fencing an exposed area for about 3 km, so as to protect the public from hazards related to fuel handling, the operation of cardiac pacemakers, interference with TV reception and home electronics [Everett 1983, 1983a].



The most modern implementations of radars are phased array radars that allow directing the beam of the radar electronically, and very quickly. The best known phased array radar in use today is the US Navy's SPY-1 Aegis, a

large passive array system fitted to Ticonderoga class cruisers. The large SPY-1 has four 3.65 x 3.65 m arrays, each with 4100 elements, and can concurrently track several hundred targets at a range of altitudes.

5.4.3.6. Traffic Radar

Traffic radars have climbed in frequency from the original X-band (10.5 GHz) to K-band (24.15 GHz) in the 1970s to the Ka-band (33.4-36 GHz) in the late 1980s. Lidar, which uses 904 nm infrared light, is also in use post-1990, and allows more accurate selection of vehicles because of its narrower beam.

Traffic radars in the X-band have a transmitter power of only 0.1 W. The power density in the beam is 36,000,000 μ W/m² at 9 cm from the antenna, but drops off to 2,000,000 μ W/m² at 30 m. Police officers frequently leave their continuously transmitting handheld radars near their groin, on their lap, between their legs, or on the car seat when not in use. Although most units have convenient on/off switches, they are rarely used. It appears that exposure should be under US thermal standards under normal conditions. However, clusters of testicular cancer have been observed in officers using radar in two small Michigan police departments, following exposures of more than a decade. In June 1992, the state of Connecticut banned the use of handheld radars, and required that the antennas of fixed systems be mounted outside the patrol vehicles.

5.4.4. Broadcasting



The use of radio-frequencies and MWs in communications is widespread and increasing. In the US, there exist 9 million

Radar Antenna

A TDWR radar antenna broadcasting 2,000 pulses per second, each 1.1 microsecond long, in the band 5.60-5.65 GHz. The system detects air downdrafts causing landing airplanes to stall and crash. The occupants in a building near the radar antenna are worried about exposure. Computations based on far-field assumptions yield the following data.

Height above Ground (m)	Average Power Density (mW/cm ²)
0	0.001
20	0.002
30	0.13
40	0.164

The values are compared to the legal limit, 3.73 mW/cm². The ratio between the limit and the actual values expected at ground level is 3,730.

broadcasting transmitters, 30 million citizen band radios, hundreds of thousands of MW towers, and tens of thousands of radar antennas.

Greater *system gain*, the product of Effective Radiated Power and receiver sensitivity, increases the range of systems. Capabilities are impressive: only a few watts of power at favorable frequencies, coupled with adequate antenna gain, can enable reliable links to distant planets in our solar system.

5.4.4.1. Broadcast Transmitters

The power densities measured far from transmitting towers and in areas accessible to the general public are typically below 1000 $\mu\text{W}/\text{m}^2$. It is believed that 99% of the US population is exposed to less than 10,000 $\mu\text{W}/\text{m}^2$. In locations particularly close to the transmitters, a fraction of a million $\mu\text{W}/\text{m}^2$ can be recorded.

Broadcast transmitters constitute a thermal hazard for **crews maintaining the towers while they are operating**. In the case of an FM tower located on Mount Wilson in California, power densities of 1,800,000,000 $\mu\text{W}/\text{m}^2$ were measured on the tower structure (tower effective radiated power, 105 kW, tower 36 m high, antenna 24 m above ground) [EPA 1978]. A survey of installations in the USSR by Dumansky [1986] showed that stations operating above 1 GHz are producing less irradiation than those operating below. Antennas often have particular emission patterns, and the levels found in nearby buildings depend on construction details and placement.

Problem 53. A radio station transmits at a power of 50,000 W. Assuming the EMR energy to be isotropically radiated (in the case of a real radio transmitter, radiation is not isotropic),
(a) what is the power density at a distance of 50 km?
(b) what is the crest electric field strength at that distance?
(c) what is the crest magnetic field strength at that distance?

Chatterjee [1985] measured the **SARs** generated by portable 1.5 W transceivers at frequencies between 50 and 800 MHz. SARs were 0.004 W/kg at 50 MHz, 0.1 W/kg at 150 MHz, 0.5 W/kg at 450 MHz, with a maximum in the eye of 1.3 W/kg, and 2 W/kg at 800 MHz. Increases with frequency was due to shorter antennas concentrating the energy over a smaller tissue mass, and to higher tissue permittivity at low frequencies.

Citizen band radios, hand-held up to 6 W, or car mounted up to 100 W, are available. Exposure measurements are made difficult by various whip antenna placements, near-field related problems, and intermittent duty cycles. However, using SAR measurements from phantoms as well as field measurements, it is possible to conclude that these devices expose users to levels of radiation very close to maximum limits [Balzano 1978, 1978a].

When transmitting antennas are grouped together in small spaces, the power density can reach high levels, such as happened in *Santa Maria di Galeria* near Rome, where Vatican Radio concentrated 60 transmitters in an area about 2 km on a side. The solution in this case would be to resort to satellite transmission [Italy 2001].

5.4.4.2. Microwave and Satellite Communications

The highly directional beams produced by parabolic antennas in MW relays use comparatively modest powers (~12 W) at 4 or 6 GHz, and produce relatively modest exposures. Power density measurements at ground level are less than 10,000 $\mu\text{W}/\text{m}^2$ (20 m tower).

Parabolic antennas designed to output signals to satellites at powers in excess of 1 MW (2-8 GHz) produce large power densities within their beam, but their remote location and focused beam pose *little environmental risk*.

5.4.5. Cellular Telephone Deployments

A newspaper account of a DeForest Co. wireless demonstration held in Montreal in 1905:

“There was no connection with the outside world, and how the electric waves could get into the big office building in mid-winter, when everything is closed as tight as a drum, seemed wonderful.”

“One of the spectators that day in the Guardian Building still remained unconvinced. Quietly he withdrew from the little crowd around the box, and went along St. James St. to the building where the wireless messages were being received. He handed in a message addressed to himself, and asked it sent to the Guardian Building. Then he hurried back. He was finally convinced of the reality of the demonstration when he found his wireless telegram waiting there for him.”

Sweden launched the first fully automated mobile phone system in 1956. The University of Hawaii installed the first wireless computer network in 1970. In the 1980s, manufacturers offered cordless phones of limited quality at 27 MHz. In 1994, digital cordless phones in the 900 MHz frequency range were introduced.

Cellular telephones allow the use of portable, untethered telephone and other services using assigned telephone numbers wherever the client chooses to go. Even if you use your phone 5 minutes per day, a dataplan will expose you to a number of “push” transmissions from all sorts of applications.

Cell phones took off in the late 1990s. Apple marketed smartphones in 2007 as essential for work, social life and even school. Wireless was promoted for streaming videos, and even for learning to read, for maps, and medical consults. Now, many governments have been led by telecom corporations into the promotion of 5G (fifth generation of wireless networks) to support increased data traffic and speed. 5G's millimeter waves would require cell sites installed every three to ten houses. This is happening even as reputable science reports substantial health risks and increased power use by 5G.

The first generation units (1G) used frequency division multiple access (FDMA) to facilitate communication. 2G phones (900 and 1800 MHz) used time division multiple access (TDMA) or code division multiple access (CDMA) for multiplexing and privacy. 3G phones (900 MHz and 2100 MHz) include Universal Mobile Telecommunications System (UMTS) wide-band CDMA (WCDMA) and High Speed Downlink Packet Access (HSDPA). 4G techniques (800, 1800 and 2600 MHz) include Long Term Evolution (LTE), and WiMAX (Worldwide Interoperability for MW Access), based on FDMA coding. It has been suggested [Morgan 2016] that modulation type impacts cancer risks, as shown in the following graph.

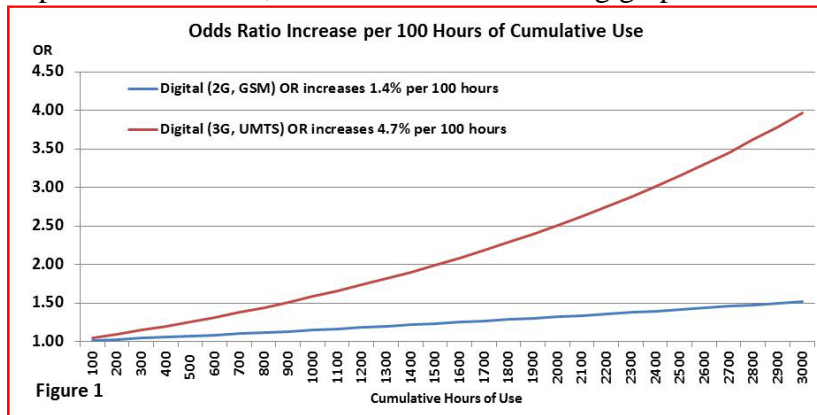

Personal communications devices functioning at much lower power (10 mW) and with substantially reduced “cell” size can offer reduced exposures to users.

SENDING DATA RELIABLY OVER THE INTERNET

According to the Transmission Control Protocol/Internet Protocol (TCP/IP), your information is divided into *packets* (network layer) holding about 1,000 to 1,500 bytes. Beyond your information, *packets* manage addressing (IP addresses of your and the destination computer), error correction, multiple transmission paths and organization of data according to frames and blocks (data link layer) and segments (transport layer). Packets include the results of a Cyclic Redundancy Check which contains the

sum of all the “1s” in the packet, added up by your computer. The receiving computer also does the same math, and if they don’t add up, your computer retransmits the packet.

5.4.6. Mobiles

The issue of cancer risk and cellular handsets has serious health implications, because it relates to the millions of pocket-sized hand-held cellular phones in use, which operate close to the user’s head. Because the units are so close to the user’s body, simple rules of power density exposure (in units of $\mu\text{W}/\text{m}^2$) cannot be applied, and it is necessary to evaluate exposures through estimates of SAR.

Some efforts have been made to reduce exposure to cellular telephone users by placing antennas near the mouth-piece rather than near the speaker, by using wired audio earphones, or Bluetooth headsets (right), which radiate only 1 mW (Class 3) at 2.4 GHz, for an effective range of 10 m, compared to 15 km for a cellular phone. But the SARs induced are still about 0.23 W/kg, in the range of the cooler cellular phones.



The European Parliamentary Assembly adopted a precautionary warning for mobile phones that emit “continuous pulse waves.” This type of radiation is emitted by GSM cell phones, which dominates most countries in the world. In contrast, CDMA cell phones have incoherent pulsed signals.



A major technical goal of industry has been reached: hiding the antenna entirely within the unit, so as not to remind the user that EMR is present. Although older models showed an antenna, newer models hide it entirely.

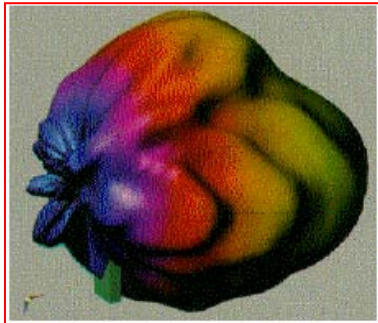

Computations show that the field of a cellular phone is complex near its antenna, and merges into a far-field pattern as distance increases.

The bottom of the cell phone is just visible at the bottom of the figure above. The high density (blue) region corresponds to the antenna.

The antennas in cellular phones are monopoles, coiled at their base to make them more compact, which results in complex vector-field arrangements, as shown, and higher field intensities at that location. (Schmid & Partner Engineering).

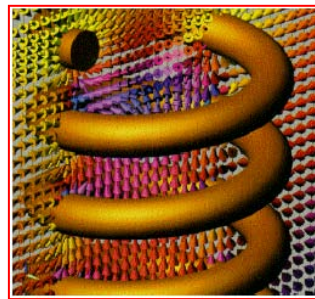

5.4.6.1. SAR

The **SAR** or *Specific Absorption Rate* is the amount of power absorbed from EMR per body weight: Watt per kilogram. **The power in tissue is proportional to the square of the local electric field value inside the tissues** and to conductivity (σ), as in Ohm's law ($P=V^2/R$):

$$SAR = \frac{\sigma \left| \vec{E} \right|^2}{2\delta} = \frac{\omega \epsilon_0 \epsilon_1 \left| \vec{E} \right|^2}{2\delta}$$

SAR is expressed in W/kg, σ is electrical *conductivity* in Siemens per meter, ω the angular frequency in radians per second, ϵ_0 the dielectric constant of free space, 8.85×10^{-12} F/m, ϵ_1 the relative dielectric constant, a pure number, δ the density (kg/m^3), and E the value of the electric field inside the heated body, in V/m.

The equation ignores the magnetic field, because the human body has essentially neutral magnetic properties. Biological tissue interacts *thermally* with EMR (which contain both E and B fields) entirely depending on the electric field vector E. The SAR, a "scalar" (a quantity containing no directional information), is therefore "insensitive" to the magnetic field magnitude.

Strong magnetic fields are necessary to interact with the atomic nuclei that have an odd number of protons, such as hydrogen. But when hydrogen loses an electron, there is potential for interaction between even very weak magnetism and the liberated electron and proton, allowing interaction of such fields with various biological processes through hydrogen bonds, for example.

But the comment above does not mean that magnetic fields are irrelevant to SAR values, since a high frequency magnetic field induces electric fields in tissue through Faraday's Law:

- ♦ The SAR equation above is actually nothing more than **Ohm's law for dielectrics** (i.e., $W = V^2/R$, see section 1.2). The conductivity that should strictly be used is

$$\sigma = \sigma_0 + \omega \epsilon_0 \epsilon_1$$

where σ_0 represents the familiar low frequency conductivity due to ion movement in ionized solutions, and the second term the high frequency conductivity related to dielectric relaxation caused by the movement of electric dipoles and the polarization of insulating membranes. In the SAR expression, the first conductivity term is neglected. The average SAR is the ratio of total absorbed power in the exposed body to its mass. A local SAR can be defined for arbitrarily small volumes or units of mass.

therefore, the “E” in the equation is the sum of the wave’s E field **plus** the magnetically-induced E field contribution.

Note also that the conductivity used (σ) is a relaxation-type conductivity (proportional to frequency, $\omega\epsilon_0\epsilon_1$) rather than the normal, familiar, frequency-independent conductivity (resistance, R). This in effect means that the heating produced is coupled to the tissue through its dielectric constant ($\omega\epsilon_0\epsilon_1$, similar to capacitive coupling: $Z=1/\omega C$).

Transformation of field measurements into SAR measurements can be done using the equation above if, of course, the *internal* electric field is known. Much work was done on the distribution of SAR in animals and models of humans (“phantoms”). Researchers attempt to relate *external* electric and magnetic fields to *internal* electric fields and SAR. *Scaling* is frequently used to estimate roughly SAR values.⁹

Even though the **Specific Absorption Rate (SAR) in W/kg** is the quantity that is basically addressed by thermally-based EMR standardization, the **Incident Power Density in W/m²**,

⁹ For instance, to determine the equivalent human exposure (SAR) at a frequency f_n for a man of height l_n and a model of height l_a exposed at a frequency f_a , the following relation can be

used:

$$f_n = f_a \frac{l_a}{l_n}$$

This relation insures that the geometrical factors relating body length to wavelength are similar [Guy, 1976]. When experimental measurements in animals or in phantoms are available, the SAR can be computed from an observed temperature rise in tissues as:

$$SAR = 4,190 \frac{cT}{t}$$

SAR = specific absorption rate (W/kg), c = specific heat of the material (cal/g.K),
T = temperature rise in Kelvin, t = time of energy deposition (seconds) (this value must be small enough for dissipative influences - blood flow if the subject is alive, conduction if the animal is dead - to be negligible).

the Electric field (V/m) or Magnetic field (A/m or μT), are the quantities used in hygiene procedures, because they can be measured, or inferred from measurements.

It is known from experiments that the SAR is maximum when the long axis of the body is parallel to the electric field, and is 0.4λ in length

5.4.6.2. Computed SARs

Magnetic fields interact more weakly with biological tissues than electric fields because the body is more “conductive” electrically than magnetically. The currents induced by these fields are affected by anatomical conductivities, and therefore result in complicated patterns¹⁰. *The conductivity and dielectric constant of biological materials are highly variable from tissue to tissue, and change with frequency.*

5.4.6.3. Measured SARs

As an alternative to computation, the practical measurement of SARs in the laboratory (on animals, cadavers or *phantoms*) uses special temperature or field measurement techniques.

A *phantom* is a physical model usually made from a mixture of simple chemicals optimized to simulate average living tissue at a given frequency, and formed to resemble human or animal body shapes.

When measuring temperature in EMR fields, special measurement techniques must be used. With thermocouples or thermistors, EMR pick-up of the leads must be avoided. Under any circumstances, this presents some difficulty. Two other problems are direct heating of the sensor by the field, and

¹⁰ The computation must consider wave propagation, complex human shapes made of tissues with different electrical properties, dielectric properties of biological materials that vary with frequency, and incident fields having complex wave shapes (pulses) must take many frequencies into account.

perturbation of the field by the thermometer. To minimize pickup, the leads can be placed perpendicular to the electric field. Magnetic induction is reduced if the leads are tightly twisted. Thermistor probes can be constructed with very resistive lead wire, so that the disturbance to the EMR field is minimal. Perhaps the best adapted method is the use of probes consisting of an optical fiber capped with a thermosensitive material. A light shines through the fiber to the material, and the reflection carried back through the optical fiber to the detector is analyzed spectroscopically. Another technique is thermography using infra-red cameras.

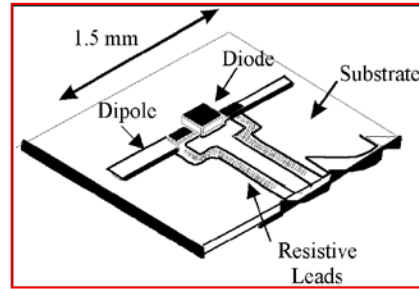

Alternately, one can measure the electric field (E), rather than temperature. Miniature implantable probes (illustrated) are built to measure electric fields in tissues.

The SAR exposures from the smaller cellular handsets are quite close (not by coincidence) to the presently accepted thermal limits of exposure. Because SAR testing is required to obtain approval for the marketing of new handsets, substantial interest has developed in this testing procedure. In practice, SARs (or the heat deposited within the body by the action of a nearby EMR emitter) can be estimated in two distinct ways: computations, or temperature measurements in models of the human head. Both of the approaches have problems. The computations are conceptually attractive, however, the fineness

and accuracy of the determinations they can provide is limited by several factors.¹¹

For their part, laboratory estimations proceed by building a mockup of a human head, sometimes using an actual human skull fitted with gels and substances that reproduce the properties of brain, muscle, skull, eye and fatty tissues.¹² Once the model is in place, a radiator equivalent in shape and in other important characteristics to the unit being tested is brought close to the human head model.

For example the iPhone 4S, with an SAR of 1.18 W/kg, is accurate only if you hold the phone 16 mm from your head. Usually, the unit itself is tested with its power output augmented by a significant factor, the high power being fed by a small cable. In this way, temperature probes inserted into the skull model can detect changes in temperature produced by the radiation. Some investigators use electric field probes. In most set-ups, the temperature probes will be patiently moved across large volumes to obtain a 3-D map of temperature elevations in the head. Obviously, probes that do not disturb the EMR field must be used. This technique¹³ has limitations: the thermal map is dependent on accurate localization and precise measurement of small temperature rises or field values, and the models are usually geometrically and dielectrically limited.

¹¹ Computational speed of the processors and memory of the computers used, availability of detailed scans of the human head, with the various tissues identified, and availability of the exact dielectric properties of all the tissues in the model.

¹² These models are rather limited in that the properties of all the important tissues of the head obviously cannot be simulated with great dielectric or geometric precision: the models are reasonably crude [Cleveland 1989].

¹³ This technique of SAR measurements has been pioneered by Arthur W. Guy. It is currently being used in a number of laboratories throughout the world, notably by Balzano [1978a] (Motorola), Gandhi [1992] and Kuster [92, 93, 93a].

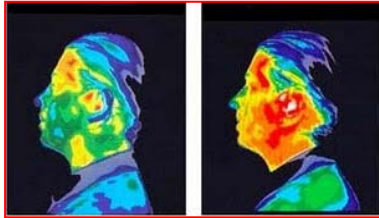

Thermographic images before and after exposure to a 15 min cellular phone call.

Children are particularly vulnerable as the average exposure from use of the same mobile phone is higher by a factor of 2 in a child's brain and higher by a factor of 10 in the bone marrow of the skull [de Salles 2006; Gandhi 2011]. Also, the child's brain is developing at a much greater rate than the adult's brain.

The SAR is the only specification necessary to obtain a permit to commercialize a cellular phone, and industry has made great efforts to keep it this way, even if heat is not an important factor determining biological impacts. GSM at 900 MHz cover an information bandwidth of 200 kHz around the carrier created by phase-modulation, and emissions are **transient bursts** of digitally coded data.

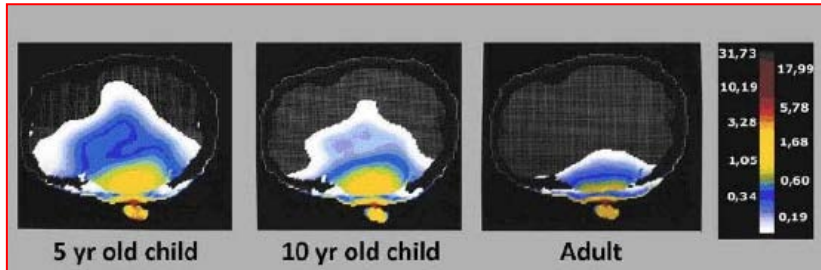

Penetration (W/kg scale) of GSM 900 MHz radiation. Gandhi et al, 1996.

**Cellular Phones (600 mW).
The legal thermal limit for Maximum/1g is 1.6 mW/1g.**

Low SAR cell phones.			High SAR cell phones.	
1	Wiko Highway 4G	0,256	Huawei P8	1,72
2	Samsung Galaxy Note 3	0,29	Alcatel OneTouch Idol 3 (5.5 pouces)	1,631
3	LG G3	0,291	Alcatel OneTouch Idol 3 (4.7 pouces)	1,277
4	Wiko Ridge	0,291	Motorola Moto G 4G	1,24
5	Wiko Rainbow 4G	0,327	Apple iPhone 5s	0,979
6	Asus Zenfone 2 (ZE551ML)	0,351	Apple iPhone 6	0,972
7	HTC Desire 620	0,362	Apple iPhone 5c	0,956
8	Samsung Galaxy Note 4	0,366	Apple iPhone 6 Plus	0,907
9	Samsung Galaxy S6	0,382	Sony Xperia Z3 Compact	0,862
10	Archos 50 Diamond	0,395	Motorola Moto G	0,79
11	Nexus 5	0,407	Microsoft / Nokia Lumia 635	0,79
12	Samsung Galaxy Grand Prime	0,412	Sony Xperia Z3+	0,74
13	HTC One M8	0,419	Sony Xperia Z3	0,691
14	Honor 6	0,422	Motorola Moto G (2e génération)	0,687
15	Samsung Galaxy S6 Edge	0,473	Motorola Moto G 4G (2e génération)	0,67
16	HTC One M9	0,518	Microsoft / Nokia Lumia 735	0,66
17	Nexus 6	0,531	LG G4	0,618
18	Microsoft / Nokia Lumia 535	0,54	Sony Xperia M4 Aqua	0,605
19	Samsung Galaxy S5	0,562	Samsung Galaxy Core Prime	0,6
20	BlackBerry Classic	0,59	Microsoft / Nokia Lumia 930	0,6

Demodulated Cell-Phone signals for GSM (TDMA) and 3G-UMTS (CDMA). Zwamborn, 2003.

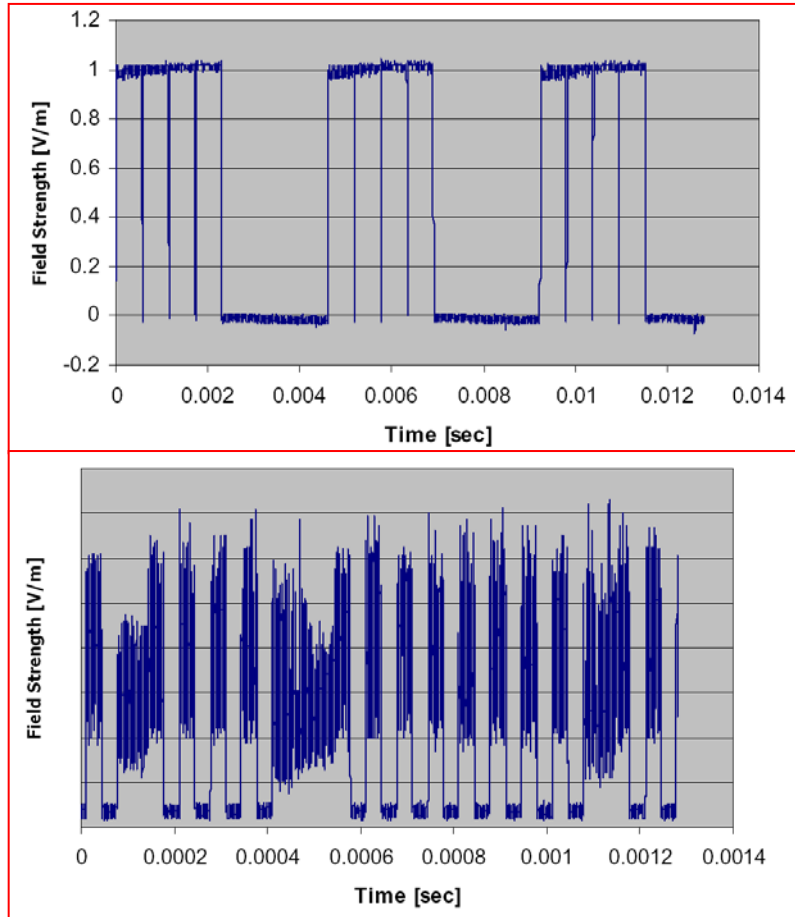

Andersen's "Phone Tree"

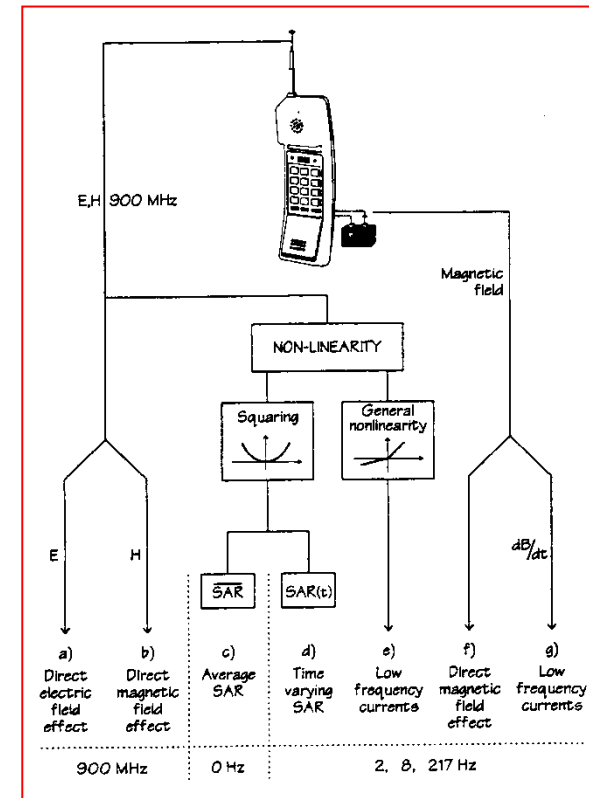

Portable Telephone

A manufacturer of a new cellular telephone model functioning at 1.9 GHz is worried about limits imposed on SAR levels in the head of the user.

Special tests are performed, both computationally and using field measurements. A detailed evaluation allows the manufacturer to change the position of the antenna, yielding an SAR reduction of 30%, which brings the SAR value below the 1.6 W/kg used as a limit.

5.4.6.4. SAR Reduction

In order to reduce user exposure to cell phone radiation. It is recommended that cell phones and all other wireless devices sold come equipped with updated software that can stop the phone from radiating when positioned against the body.

Cell phones contain proximity sensors that will allow a cell phone to only radiate signals when a certain distance from the body, for example, held in the fingers or placed on a table. This does not change the functionality of the device, only the way it is used, specifically not held against the head or body.

Implementation is a software update in the cell phone, as these phones already have a proximity detector to turn off the screen and soft keys when an obstacle is present. With this change, the screen and the RF circuit are automatically turned off. This removes the problems of brain cancers (glioblastomas and acoustic neuromas) and the issue of SAR limits for the industry. Cell phones should come set with this inhibition, with instructions in the manual on how to disable it. There should be a soft button on the unit to easily re-enable the radiation inhibition, for example if the unit is handed to a child. In all cases, it should be easier to enable the restriction than to disable it. Cellular phones marketed specifically for children should stop radiating when positioned against the body under all circumstances. The installation of such proximity sensors is also encouraged in laptops and tablets.

The FCC testing procedure for certification of cell phones aims for a power injection into the head below 1.6 Watts per kilogram of tissue. The accuracy of SAR



determinations is not very high (variation between laboratories), and some cellular phones have been found to exceed this limit [Chicago Tribune 2019]. A major problem is that the FCC testing procedure allows the phone to be tested up to 0.98 inches (2.5cm) from the head, at which distance injection of energy into the head is much reduced compared to when held against the head as is done routinely by users. “Small print” instructions already present in many cell phone manuals instruct users to hold cell phones at a distance from the head, in full knowledge that this is not likely to be done. In France, measurements by the National Frequency Agency (ANFR) revealed that 9 out of 10 mobile phones tested in 2015 under real use conditions (in contact with the body) exceeded the legal limit, leading to extensive recalls [PhoneGate 2019]. We provide here a simple change expected to reduce the number of glioblastomas and other tumors in cell phone users by mandating that cell phones turn off their radiation when held right against the head or body.

IMPLEMENTATION

A reliable method to reduce head exposure to radiation is to configure the phone itself to automatically shut off, protecting the user’s brain. Cellular phones already contain a small device called a *proximity sensor* (shown at right is the miniature Sharp GP2AP002S00F), usually located at the top of the phone. The element on the left of the sensor sends out pulsed infrared which is detected by the element on the right, if the phone is near an object. The image sequence at right shows how a finger turns off the screen. In present Android devices, the proximity sensor triggers as the user’s face is close to the screen, switching off the screen and preventing any errant soft-button presses by the skin as well as saving battery power.



Some Android devices can report the distance to another object in centimeters, whereas others will simply report minimum and maximum values to denote *near* and *far*, respectively. These functions are accessed through *SensorManager* and *Sensor* classes from the Android Application Programming Interface (API).

Similarly, the iPhone proximity sensor (also using infrared) is designed to detect any object near the screen and is used to put the display to sleep when the iPhone is against the head, preventing unintentional display triggering. Assigning to the user the task of keeping the phone away from the head is not practical. The phone itself should disable its RF emissions if proximity is detected. This means that the user could use the phone away from the head, in his hand, or on a table in front of him. At the cost of a small change in personal habits, this measure would instantly remove high SAR exposures from cell phone usage and would remove the need for sophisticated assessment of exact SAR measurements in close body proximity. Note that this phone adjustment does not prevent alerting the user to incoming calls. But it does prevent the unit from autonomously sending out data when held against the body. A number of applications (“apps”) have in recent years contributed to user exposures by radiating data even without user intervention. This automatic data traffic tends to increase and should only be permitted if the device is held away from the body. Essentially, this software adjustment is an automated “Airplane Mode”, designed to protect users from radiation.

JUSTIFICATION

For cellular phones, commonly held against the head, prolonged use has led to an increase in a lethal form of brain cancer, glioblastoma, as well as with a more benign tumor, acoustic neuroma, in 9 peer-reviewed studies, including one cohort study [Philips 2018; Hardell 2013; NTP 2018; IARC 2013; Chou 1992; Repacholi 1997; Bioinitiative 2012].

Recent studies have also linked cell phone use to cancer. Engineering analysis indicates that the dose delivered to the brain decreases rapidly as distance between cellular phone and head rises. As shown below, decreases by as much as 4 to 5 times, according to two separate analyses, as the phone is moved 1 cm (0.4”) away.

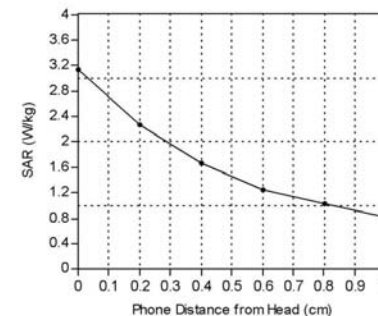

A comparative study of the distance effects of human head from mobile phone radiation. S. Imran Zaman, S. Y. Khan, At-Tin Malik, Akhlaq Tariq. International Journal of Microwave and Optical Technology, Vol. 10, No. 1, January 2015.

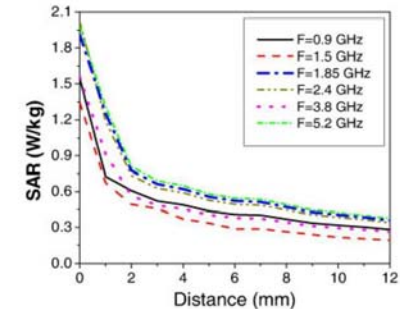

Design of low sar planar monopole antenna for mobile wireless communication applications. Dalila M. E. Ibrahim and Esmat A. Abdalrhah. Progress in Electromagnetics Research M, Vol. 29, 137-149, 2013.

While walkie-talkies of the past were used more distantly from the head, the recent trend has been to reduce the size of cellular phones and to promote a style of use identical to that of the telephone which is pressed against the ear. An unfortunate consequence has been to deliver large doses of EMR to tissues of the nervous system which have been shown to be adversely affected, as stated above.

Without altering the function of cellular phones, it is technically possible to seriously reduce exposure to the brain of users by altering how the phones are held when emitting radiation, specifically by holding them away from the body.

5.4.7. Base Stations: the Killing Fields

Cellular systems need two basic organs: base-stations and mobiles (hand-sets). The range of a standard base-station may be up to 35 kilometres, a microcell is less than two kilometers

wide, a picocell is 200 meters or less, and a femtocell is in the order of 10 meters.

The typical antennas of cellular base stations are omnidirectional co-linear arrays (groups of vertical antennas) 40 to 80 m from the ground. The typical effective radiated power from one antenna is 100 W *per channel*. The representative public exposures produced by these antennas at sites nearest the base-stations (but not in the main beam) were found to be less than 100 $\mu\text{W}/\text{m}^2$ *per radio channel* [Petersen 1992]. At the top of the cellular tower, the thermal limits of approach to single cellular antennas are thought to be approximately 0.7 m for *controlled* exposures, and 3 m for *uncontrolled* exposures.

As cellular telephones become increasingly popular, industry presses for more antennas. The antennas are mounted on mountains, towers, rooftops, water tanks or any structures that provide adequate height. They are an eye-sore. In cities, there is an increasing effort to use panel antennas, flat, directional, radiators which may be placed against building surfaces. Unfortunately, the structures are not always discrete, especially in the countryside, where the tall towers that are required for large cell coverage must be painted in alternating red and white stripes, to support Visual Flight Rule aircraft safety.

Dode 2011 provides the most detailed information. Belo Horizonte is the third largest city in Brazil. It was been selected by the Population Crisis Committee of the United Nations (UN, 2007) as the metropolis with the best quality of life in Latin America. Its health system is considered very good, according to the Atlas of Human Development (2000)/United Nations Development Program).

In 2011, a 10 year study on cell phone antennas was released by the Municipal Health Department and several local universities. The study was conducted in a broad

environmental context, aiming to verify if there is a spatial correlation between the cellular telephony system BS location and the cases of death by neoplasia during the period between 1996 and 2006. Three data banks were used: 1. death by neoplasia documented by the Municipal Health Department; 2. BS documented in ANATEL (Telecommunications National Agency); and 3. census and demographic city population data obtained from official archives provided by IBGE (Brazilian Institute of Geography and Statistics). The results show that approximately 856 BSs were installed through December 2006. Between 1996 and 2006, 7191 deaths by neoplasia occurred and within an area of 500 m from the BS, the mortality rate was 34.76 per 10,000 inhabitants. Outside of this area, a decrease in the number of deaths by neoplasia occurred. The greatest accumulated incidence was 5.83 per 1000 in the Central-Southern region and the lowest incidence was 2.05 per 1000 in the Barreiro region. During the environmental monitoring, the largest electric field measured was 12.4 V/m and the smallest was 0.4 V/m. The largest power density was 407,800 $\mu\text{W}/\text{m}^2$, and the smallest was 400 $\mu\text{W}/\text{m}^2$.

Populations residing near cell phone base stations have a significantly lower mean value of manganese superoxide dismutase (MnSOD) enzyme activity, catalase (CAT) enzyme activity, and a high value of lipid peroxidation assay in exposed as compared to control subjects. A significant association of genetic polymorphism of antioxidant genes with genetic damage has been observed in human population exposed to radiations emitted from mobile towers [Gulati 2018]. The fields radiated by cellular base stations have been shown to induce a variety of risks.

5.4.7.1. Base Station Exposure Reduction (500 m)

India already prohibits placement of cell phone towers near schools or hospitals, and Canada (Standing Committee on Health) as well as many European countries are looking into siting guidelines for cell phone towers. Siting restrictions are intended to insure the safety of vulnerable populations like kids and those with illnesses. Since these individuals are sprinkled everywhere in society, a set-back requirement for new base-station (BS) cellular towers, including micro-towers, should be based on the Largest Observed Adverse Effect Distance (LOAED), and could be universally applied.

Since there is no epidemiological experience with 5G and since exposures are intended to rise and become more irregular with 5G, a conservative LOAED should be based on observations from the past, and include all observed health effects.

Best engineering practice would therefore apply a set-back requirement for new cellular towers, including 5G micro-towers. From the documents referred below in historical order, this **set-back for all new cell towers should be 500 meters**. All of these studies have been given support by a recent animal study from the Ramazzini Institute that links to them, as well as to the US National Toxicology Program result on cell phones.

Michelozzi 2002 describe very high relative risks for lymphomas, myeloma and leukemia, and for non-Hodgkin's lymphoma at distances up to 6 km from the powerful Vatican Radio transmitters near Cesano, Italy, which led to compensation by decision of Italy's Supreme Court.

Santini 2003 surveyed by questionnaire 530 people living or not in proximity to cellular phone BSs in France. Eighteen

different symptoms (Non Specific Health Symptoms-NSHS), described as radiofrequency sickness, were studied. Certain complaints are experienced only in the immediate vicinity of BSs (up to 10 m for nausea, loss of appetite, visual disturbances), and others at greater distances from BSs (up to 100 m for irritability, depressive tendencies, lowering of libido, and up to 200 m for headaches, sleep disturbances, feeling of discomfort). In the 200 m to 300 m zone, only the complaint of fatigue is experienced significantly more often when compared with subjects residing at more than 300 m or not exposed (reference group). For seven of the studied symptoms and for the distance up to 300 m, the frequency of reported complaints is significantly higher ($P < 0.05$) for women in comparison with men.

Khurana 2010 provides a review of 10 BS proximity and neurobehavioral effects, and three investigations of cancer. Eight of the 10 studies reported increased prevalence of adverse neurobehavioral symptoms or cancer in populations living at distances < 500 meters from BSs.

Pearce 2020 provides the most recent assessment, and promotes a 500 m set-back to limit future liabilities of the cell phone industry, based on correlation with headaches, dizziness, depression and other neurobehavioral symptoms, as well as increased cancer risk.

Koppel 2019a observes that in practice, base stations are often installed in high risk areas without functional justification.

Affuso 2018 examines the economic impact on home values. For properties located within 0.72 kilometers of the closest tower, results reveal significant declines of 2.46% on average, and up to 9.78% for homes within tower visibility range compared to homes outside tower visibility range.

It is almost inevitable that such economic impacts will increase in the future.

5.4.8. Smart Meters

The goals of electrical utilities of cutting costs and power consumption crests have been implemented by imposing on the whole population a supplementary EMR regime of millisecond-long pulsed MWs. It has also created the opportunity for an infrastructure aimed at retrieving information from homes (Zigbee chip, Internet of Things). Problems are that emissions are much more frequent (9,600 to 190,000 pulse per day) than is necessary to accomplish the needed power billing functions because many utilities adopted a meshed cellular structure that passes information from one unit to the next, and that is true even before Zigbee activation for IoT. The electrical utilities' internal culture denies any health effects of EMR, including leukemia in children.

5.4.9. Cordless Phones

The signals from older analogue cordless phones are at a constant level of 10 mW, whereas the signals from modern digital cordless phones are in the form of 100 bursts every second, each of around 0.4 msec duration. The bursts are at a peak power level of 250 mW, but on average the phone only transmits for 1/25 of the time, and so the average power is 10 mW. The risk of brain tumor (high-grade malignant glioma) from **cordless phone** use is 220% higher (both sides of the head). The ipsilateral risk from use of a cordless phone is 470% higher than baseline. This cordless *average power* of 10 mW compares to 600 mW for cellular phones, a ratio of 60. The *peak power* of cordless phones is 250 mW compared to GSM cellular phones at 1 to 2 W, a ratio of 4 to 8. If the epidemiological data is confirmed, it appears that *peak power* rather than *average power* may be the determinant of health outcomes, contrary to the thermal risk philosophy.

5.4.10. Computers and Office Local Area Networks

In spite of the demise of cathode ray tubes, there are emissions from desktop and laptop computers that incommodes sensitive users. Older Dell and new Toshiba laptops seem to work well for electrically sensitive people. Anything by Apple, along with HP's and the newer Dell laptops are often high EMR machines. Use low-power units, solid-state drives, and wired category 6a hard-wired connections.

As early as 1995, 45,000 wireless LAN systems were shipped annually in the US. Apple Computers, supported by Motorola, NCR and IBM, has petitioned the US FCC to set aside 40 MHz of the radio spectrum (1,850 to 1,990 MHz) for personal computer networks. These Data-Personal Computer Services use 1 W of radio power which goes through most walls, and covers a 50 m radius. This is happening at a time when cases of health effects from cellular phones are beginning to appear. Promotion of wireless is pervasive, with no apparent thought of health consequences [Koppel 2019; Massardier-Pilonchery 2019; Velghe 2019; Wall 2019].

5.4.11. Laptops

Laptops, often held against the body, have not been engineered to reduce operator exposures to ELF or RF-MW.

5.4.12. Internet of Things and 5G

The engineering dream of the Internet of Things (IoT) would link every device in existence to the Internet (George Orwell's 1984). IoT aims to equip all possible devices with communications. Internet Protocol v6, 2^{128} , is replacing IPv4, 2^{32} , boosting Internet addresses from 4.3 billion to 340 trillion trillion. If each of these addresses were used by a device

the size of a cell phone, the total material would fill all of the space between the orbit of Earth and that of Mars!
 The Internet already uses 5% of global electric power, and may reach 20-50% by 2030 [Morley et al 2018]. Will the proliferation of telecom signals wished for by engineers create EM noise levels incompatible with human life?
 IoT would coincide with 5G [Webb 2016] over the next several decades. This would dramatically increase the number of transmitters sending signals to cellphones and Internet-enabled devices. But to use this higher frequency part of the spectrum, wireless companies would have to install thousands of small base stations — some just the size of smoke detectors — on utility poles and buildings to pass the signals along. A station would be needed for every 5-12 homes in a dense urban area. 5G would present additional concerns because there will be more energy density in signals traveling over the high-frequency spectrum, and the smaller transmitters will be closer to where people live and work, making 5G signals harder for people to avoid.

5.4.13. Electromagnetic Compatibility (EMC)

The term *EM Compatibility* designates interference *between active electrical devices*, that leads to malfunction. When devices are critical, such as pacemakers, defibrillators, electronic lung ventilators, infusion pumps, anesthetic delivery, and dialysis machines or electronic safety systems, the consequences of the interference can be life-threatening. Problems of EMC were dramatized in 1963 when it was realized that high altitude atomic bombs create broadband EMR pulses that disrupt electronics.

Engineers design *emission standards* to eliminate EMC problems. Emission standards are sets of rules, usually national in scope, which limit EMR from commercial devices, with a

USE OF LAPTOP COMPUTERS CONNECTED TO THE INTERNET THROUGH WI-FI DECREASES HUMAN SPERM MOTILITY AND INCREASES SPERM DNA FRAGMENTATION.

Conrado Avendaño, M.S.a, Ariela Mata, M.S.a,
 César A. Sanchez Sarmiento, M.D., Ph.D.a, Gustavo F. Doncel, M.D.
<http://tinyurl.com/6vg744c>



“Microwave Technology Is Unsafe and Should Not be Used in Schools...” Martha Herbert, M.D. Harvard Pediatric Neurologist.

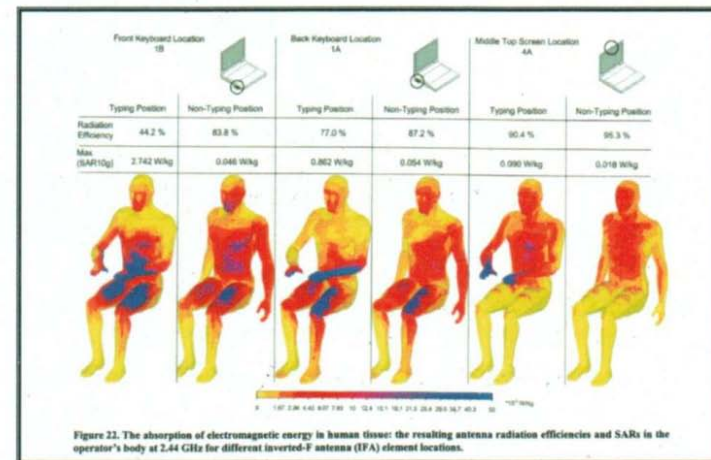

view to keeping the EM environment useable for all applications. However, with any new technology, there is potential for surprises. Interference of mobile phones with medical devices is documented [Bassen 1993; Badizadegan 2019].

Many hospitals have old electronic equipment which have discreetly failed, but show no obvious problem. The failures may originate in the circuit themselves but be intermittent, or they may manifest with interference from extraneous devices such as cellular phones.

5.4.14. Interference Sources

Many cellular phones users do not understand that the units “handshake” with their base-stations periodically to confirm networking, so they only put their units on *standby*. Many hospitals require that the units be set to *airplane mode*, which eliminates RF radiation. When boarding a plane, passengers are forbidden to use portable phones, because of potential interference with aircraft communications or controls, though *in principle*, there should be no problem, because of different frequency assignments.

But the only way to eliminate all radiation is to turn *off* the phone.

Heart patients wearing pacemakers and implanted defibrillators should avoid putting cellulars (GSM, TDMA) and media players in their breast pockets, as the cellular emissions and magnets in the headphones can deactivate the devices. The pacemakers are particularly susceptible to frequencies near 8 Hz, and some digital phone emissions do contain such frequencies.

For example, many Apple products could interfere with implanted pacemakers and defibrillators: AirPods, Watch, HomePod, iPad, iPhone, MagSafe, Mac, MacBooks, iMac, Pro Display XDR and Beats (<https://support.apple.com/en-us/HT211900>). It is recommended to hold such units 15 away from the body, and 30 cm away, if wirelessly charging.

Some digital cellular phones interfere with hearing aids, and individuals may need special choices to use a cellular phone in the assisted ear (individual unit immunity ranges from 1 to 40 V/m). But it has also been observed that WiFi exposure affects hearing itself [Yorgancilar 2017].

The immunity of many devices to cellular phone electric fields is about 3 V/m. This includes Hearing Aid, Television, Radio, Amplifier, Telephone, Computer and CD Player. The peak field strength of GSM phones are approximately as given in the following table.

Peak Field Strength of GSM Phone		
Power	at 1 m	at 2 m
0.25 W	4 V/m	2 V/m
0.8 W	6 V/m	3 V/m
2 W	10 V/m	5 V/m

5.4.15. Filtering

Since wires can act as antennas, it is particularly important to insure that this path of entry into sensitive circuitry is blocked.

Devices not supplied by batteries have power supply connections, or other wiring connected to them. Power supply connections are not currently wired by coaxial cable, so are susceptible to pick up high-frequency signal from the environment, or to pass-on



spurious high-frequency signals from the electrical network.

To safeguard the purity of a power supply line, *line filters* are available [Pong 2018]. To be effective, the filters must address both common-mode (ie, same direction) and differential-mode (opposite direction) interference.

Since the common mode current (in red in figure below) creates additive magnetic fields in the choke (red arrows), the incoming red pulse “sees” a high impedance, which limits transmission of the pulse to the load side of the filter. Magnetic fields produced by differential-mode currents (blue) in the choke cancel each other out, so the choke presents no impedance to differential-mode currents. The two C_y capacitors also form a common mode filter, as the meeting pulses of similar polarity can only flow to ground. C_1 and C_2 function as voltage dividers with the imbalance and leakage inductance of the choke to form differential mode filters (C_1 filters from load to line, C_2 from line to load). Typically, C_y is 4.7 nF, C_1 and C_2 are 0.22 – 0.47 μ F.

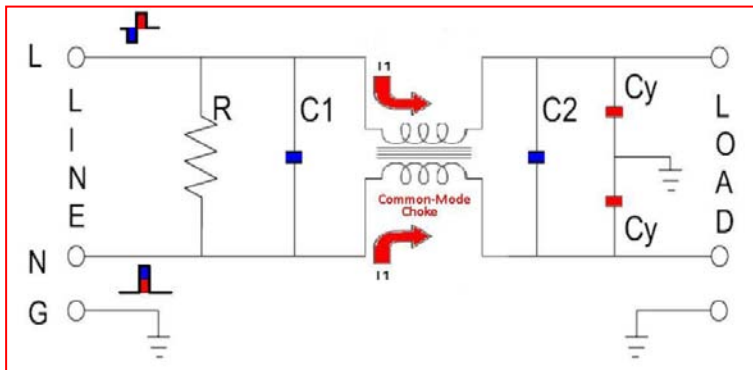

A simpler way of filtering common mode interference is to slip a ferrite cylinder around a cable (illustrated here on a USB cable). The



ferrite locally magnifies the inductance of the wires, attenuating the transmission of all frequencies higher than those intended to be carried by the wire.

5.4.16. Perspective on Wireless Risks

The “off the leash” deployment of wireless systems has resulted in the creation of a new population of sick people, as well as health impacts that are still ignored by health authorities, in great part due to industry lobbying. The chronic risks associated with wireless can only be assessed after the long delays involved in cancer and other diseases appearance, and epidemiological analysis. Consequently, we should be careful in gauging the risks associated with any new “G”. The power density levels are determined by the size of the cells, and the base-station and handset sensitivities. Power levels for cellular handsets are dynamically controlled (and re-evaluated every 1.2 msec). The maximum power radiated is 600 mW, but it can be reduced in five 4 dB steps to as little as 6 mW (the steps are 600, 239, 95, 38, 15 and 6 mW).¹⁴ As a user moves about, the power radiated by his phone can vary wildly. This existence of this dynamic power management system is one of the main arguments used to point out that cellular exposures are not as large and significant as a simple laboratory test performed to simulate stable, 600 mW effective radiated power, would suggest. On the other hand, more conservative people argue that in an open space, on the fringe of a cell, it is possible that the power would be maintained near the maximum level for as long as the call lasts.

¹⁴ The system is necessary to save battery power, control interference, and avoid signal fading in certain unfavorable placements of the handset.

5.4.17. Internet of Things

The *Internet of Things* (IoT) is a wild vision placing RF emitters in all commercial products, to serve a supposedly unlimited need for wireless communications. Implementation of this concept could lead to a huge expansion in EMR exposures to humans. IoT seems blind to many practical hurdles, to actual consumer needs, as well as to human health impacts.

Although there may be threshold for individual biological effects of EMR, the threshold to the action of EMRs for the full collection of physiological systems is certainly very low.

The dose-response for some effects may be flat, as suggested by ELF results, may be related to time above specific thresholds, or may depend on tissue physiological state. We are not close to recognizing fully the health impacts of wireless communications. In the meanwhile, various recipes of EMR modulations are regularly being deployed by engineers oblivious to potential health effects, compliments of a rooted thermal standard.

5.4.18. Health Care

5.4.18.1. Diathermy



Deep heat is applied in this technique against *pain, arthritis and muscle spasms*. Both RF and MW frequencies are used. One or two *applicators* (an antenna designed to transfer energy to the subject)

can be used, and the units consist of a generator feeding the applicators through a length of waveguide or coaxial cable [Tofani 1984; Lau 1984]. In the case of MW units (2450 MHz), at 5 cm from the treatment area, field leakage levels were recorded between 10 to 440,000,000 $\mu\text{W}/\text{m}^2$. Operators, at the control console, were reported to be exposed to 13,000,000 $\mu\text{W}/\text{m}^2$.

EMR units at 27.12 MHz seem to present a greater thermal exposure problem, operators being subjected to 80 to 170,000,000 $\mu\text{W}/\text{m}^2$. Many units deliver power through two wires forming an unshielded transmission line. It is apparent that more protection is needed through shielding of the leads, and remote positioning of the operators. Treatment configurations would typically result in 100,000,000 $\mu\text{W}/\text{m}^2$ at 1 m from the electrodes.

Practical recommendations are as follows:

- 1. Leakage to Patient:** Radiation beyond the intended treatment area should be limited. Upon initial installation of a unit, a field survey should be conducted to confirm this (possibly on a phantom, or on a patient, at reduced power, with the appropriate scaling being used, to determine safe limits). Both electric and magnetic fields should be measured. No metal furniture should be used and other large metal objects should be at least 3 m away. Patient should remove all metal objects (be aware of metal implants and pacemakers). The applicators should conform to the treatment area as closely as possible, and the power wires should not be placed along the patient.
- 2. Leakage to Operator:** Electrodes should be placed as close to the treated area as possible, and power should be turned on only after electrodes are in place. *Operators should be as far away as possible from electrodes and wires.*

3. **Miscellaneous:** Power controls, indicators, EMR power stabilizers, with safety interlocks should be installed (a patient-operated safety switch is a good idea). Quantification of heating effectiveness through tests using phantoms should be done whenever equipment is altered. Flammable material should not be placed near electrodes or wires. Pregnancy is a contraindication.

A study of American male physiotherapists concluded that chronic exposure to EMR energy at 27 MHz yields a positive association with heart disease [Hamburger 1983].

5.4.18.2. Oncological Hyperthermia

Cancer therapy using **hyperthermia** uses first the particular sensitivity of malignant cells to heat and secondly the fact that large tumors have poorer perfusion than surrounding tissues, and therefore cool with more difficulty. RF and MW frequencies are used for hyperthermia, mostly in the context of research programs. For muscle surrounding the tumor, for example, the allowed exposure limits are 44°C for 20 minutes.

5.4.18.3. Electrosurgical Devices

Used for *cauterizing* (control of hemorrhage) and cutting tissue, electrosurgical devices are currently used **in almost all operating rooms**. These units output high frequency (2 MHz) oscillations attenuating to zero within 20 milliseconds and at repetition rates of approximately 3 kHz. When dielectric breakdown occurs between the bipolar electrodes, high frequency components may be obtained (to 100 MHz). At maximum power, 1000 V/m can be obtained at 16 cm. Since surgeons are often close to the cauterizing tool, **intermittent exposure to 2,650,000,000 $\mu\text{W}/\text{m}^2$ can be expected**. *In view of the proximity of the surgeon's head, induction of cataracts would be a potential hazard* [Fox 1978].

5.4.18.4. Pacemaker Sensitivity

Sensitivity of pacemakers to MWs has been largely eliminated by a variety of electronic filtering countermeasures. The units are typically tested at 450 MHz, where susceptibility is greatest. There are obvious contraindications for MW diathermy treatments.

Antitheft detector portals in retail stores can interfere with implanted electronic devices such as pacemakers. A report found that the a large majority of subjects are affected temporarily [McIvor 1998], but without serious consequences [Santucci 1998].

Investigators conducted *in vivo* tests in patients with pacemakers and implantable cardioverter defibrillators, to determine the impact of the primary magnetic flux generated by standard airport detectors on the pacing and sensing capabilities of each device. From these tests, it appears that Airport Metal Detectors are safe for pacemaker and implantable cardioverter defibrillators patients [Kolb 2003a, 2003b].

5.4.18.5. Nuclear Magnetic Resonance

Nuclear Magnetic Resonance is one of the more stunning recent developments in the medical field; it can see tumors and other abnormalities inside the living body. It is the best method for finding lesions associated with multiple sclerosis, and knee-

joint problems, among others. For a simple demonstration:

<http://www.youtube.com/watch?v=1OrPCNVSA4o>

NMR provides clear images of parts of the body surrounded by dense bone,

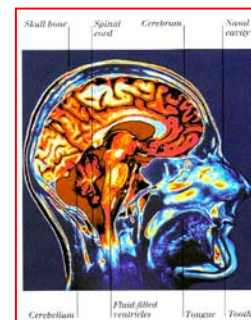

making it valuable for brain and spinal cord imaging. Images enhance the density of hydrogen atoms [Dorling Kindersley 1998].

Based on the movement of the body's magnetic nuclei, as controlled by dc magnetic fields of approximately 2 T, NMR does not use potentially harmful ionizing radiation, an obvious advantage over computed tomography (CT) scans. Advances include cine-NMR for cardiology, contrast enhancing dyes (gadolinium) and super-conducting materials (see brief description on next page).

There are, however, some hazards [Adams 1986; Athey 1982].

✚ The “projectile” effect: metal objects like pens, paper clips and even oxygen cylinders are rapidly pulled onto the powerful NMR magnets. Anyone standing nearby can be seriously injured by the flying objects, and such items must be carefully removed before the instrument is started. This metal-to-magnet reaction remains a problem with *patients carrying metal items such as shrapnel or implants*. Also, adhesive patches for delivery of medication can cause skin burns.

✚ Electro-magnetic incompatibility: Magnetic Resonance Imaging should not be used on patients with cardiac pacemakers, and caution should be taken with patients on life-support systems. Patients should be screened for implanted neurostimulators, even if the device is off. Removed neurostimulators are a risk because portions of leads often remain in the body, may act as antennas, and become heated.

✚ Although the current NMR procedure appears to be relatively innocuous to patients and medical personnel in clinical practice, more studies should be done on the long term effects, as the magnets are becoming more powerful. There are scattered reports of abnormal development from *in vivo* and *in*

vitro tests. NMR fields enhance calcium transport *in vitro* in rat thymocytes and in human peripheral blood lymphocytes, particularly in mature subjects. The technique should not be used in the first trimester of pregnancy, unless it offers a definite advantage over other tests.

✚ Care should be taken in patients who for some reason cannot release body heat normally, as NMR can cause localized temperature increases in tissues.

The procedure uses a strong magnetic field, as well as EMR at nuclear resonance frequencies, at doses as large as 4 W/kg for durations of as long as 20 minutes. *Temperature rises are the largest on the skin* (0.5 to 3.5 K, depending on their location near the isocenter of the scan). It is recommended not to exceed 2 W/kg for periods less than 15 minutes and not to exceed 1 W/kg for exposures longer than 15 min (averaged over any 25% of body mass),

✚ There appears to be little thermal concern for the personnel operating the devices. Outside the bore magnet and coils, the EMR exposure values are $\sim 500,000 \mu\text{W}/\text{m}^2$ (0.03 μT ; 14 V/m). Recommended dc magnetic field exposure limits for operators are 0.01 T for 8 hours/day. Transient exposures for 10 minutes/hour: 0.1 T for whole body and 2 T for arms and hands. Measured exposures showed 100 mT for 5 minutes per patient (for proper patient placement), and 1 mT otherwise, near the operating console, during scanning.

The apparatus for Nuclear Magnetic Resonance Imaging includes magnets applying a magnetic field and magnetic field gradient (the four narrow rings), and EMR coils (the inner cylinder) [Rubenstein 1988].

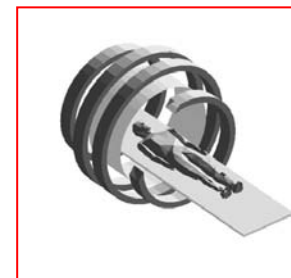

The more recent and powerful NMR machines (4 T) may induce feelings of nausea [Schaap 2015], perceptions of flashing lights, and tastes of metal in certain subjects.

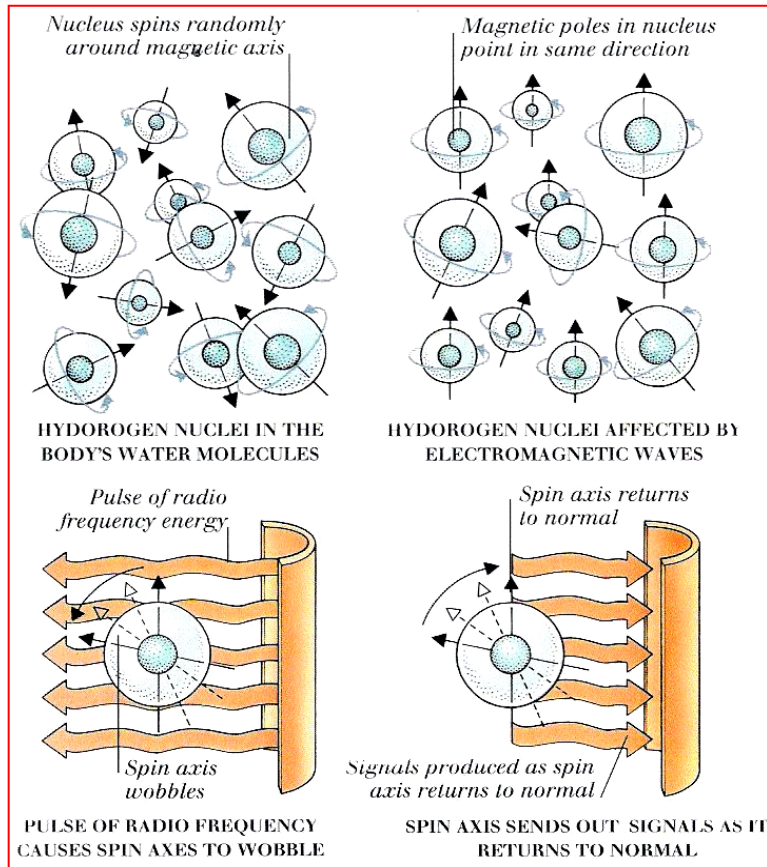

Unpaired protons in the nucleus of atoms are miniature magnets with a north and south pole. In normal material, the magnets are randomly oriented (upper left). With the high (2 T) static magnetic field of NMR, they align with the field (upper right). EMR radiation directed at right

angles to the magnetic field will flip the magnets, if the radiation has the correct frequency (lower left). When the radiation is removed, the flipped magnets will return to the normal position, releasing the energy which caused their flipping in the process (lower right) [Dorling Kindersley 1998]. In NMR spectroscopy, it is possible to infer from spectral measurements which atoms are bound to which, in a molecule.

MRI can cause serious injury in patients with implanted neurostimulators. There have been several reports of serious injury, including coma and permanent neurologic impairment, in patients with implanted deep brain and vagus nerve stimulators undergoing MRI procedures. These events involve tissue injury caused by the heating of leadwire electrodes, so similar injuries could be caused by any type of implanted neurostimulator, including spinal cord, peripheral nerve, and neuromuscular devices.

5.4.18.6. Transcranial Magnetic Stimulation (TMS)

TMS induces electrical currents in the brain using magnetic fields. A number of different coils produce different magnetic field patterns. Some examples:

1. round coil: the original type of TMS coil,
2. figure-eight coil: results in a more focal pattern,
3. double-cone coil: conforms to the shape of the head, useful for deeper stimulation,
4. deep TMS (or H-coil): used in the treatment of patients suffering from clinical depression,

5. four-leaf coil: for focal stimulation of peripheral nerves [Roth 1994].

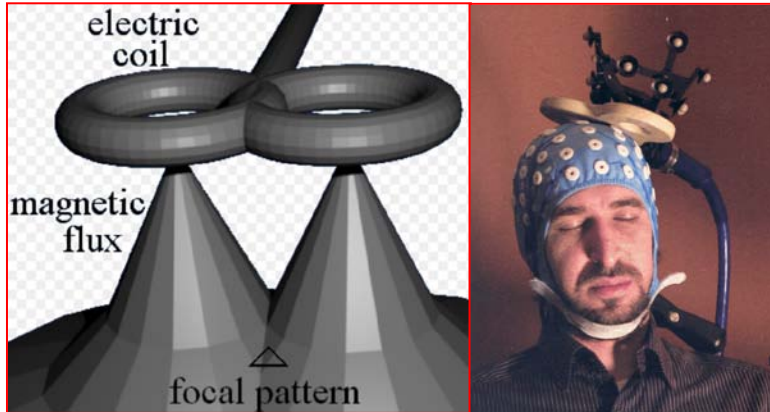

Coils encased in plastic are held to the head. A large capacitor rapidly discharges a current into the windings, producing a magnetic field reaching directly beneath the treatment coils, and about 2-3 centimeters into the brain. With stereotactic MRI-based control, the precision of targeting TMS can be a few millimeters. The induced brain currents flow tangentially to the skull, activating nearby nerve cells as if applied directly to the cortex. The current paths are complex, as the brain is a non-uniform conductor with an irregular shape. Repetitive Transcranial Magnetic Stimulation (rTMS) has caused seizures in normal individuals at certain combinations of stimulation frequency and intensity. Guidelines have since been instituted regarding the maximum safe frequency and intensity combinations of rTMS [Wassermann, 1998]. Multiple studies support the use of this method in treatment-resistant depression; it has been approved for this indication in Europe, Canada, Australia, and the US.

Typical exposure parameters

- ✚ magnetic field of 0.5 T in the cortex,
- ✚ current rise time: zero to peak, often around 70-100 μ s,
- ✚ waveform: monophasic or biphasic,
- ✚ repetition rate for rTMS: below 1 Hz (slow TMS), above 1 Hz (rapid-rate TMS).

In a 20-minute exposure producing only a mild tapping sensation on the scalp, 1,600 magnetic pulses applied to the left side of the head improved functional memory and increased blood flow in the hippocampus and four brain regions thought to interact with the hippocampus, suggesting better connections between those areas [Wang 2014].

5.4.18.7. Neonatal Incubators

Fields as high as 10 μ T interfere with melatonin production and vagal tone, among others [Bellieni 2017].

Problem 55. Use the expressions

$$\text{SAR} = \sigma |\vec{E}_i|^2 / 2\delta \quad \text{and}$$

$$\sigma = \sigma_0 + \omega \epsilon_0 \epsilon_1$$

to explain (1) what terms influence the SAR while heating an electrolyte using 60-Hz current and (2) heating water using MWs.

5.5. Exposure Standards

5.5.1. Recommendations for Protection

The Russian National Committee on Non-Ionizing Radiation Protection wrote in 2017: “It has just come to our attention that the WHO RF Working group consists mainly from present and past ICNIRP members. In general, the Working Group is not balanced and... the private self-elected organization ICNIRP, similar as majority of the current WHO RF WG members, does not recognize the non-thermal RF effects. Thus, the guidelines of ICNIRP are irrelevant to present situation when majority of population over the world is chronically

DIVERGENCE OF OPINIONS

2012			2016			1973	
AUSTRIAN MEDICAL ASSOCIATION			EUROPAEM			ICNIRP	
	RF-MW ($\mu\text{W}/\text{m}^2$)	ELF (nT)		RF-MW ($\mu\text{W}/\text{m}^2$)	ELF (nT)	RF-MW ($\mu\text{W}/\text{m}^2$)	ELF (nT)
Excessive						>10,000,000	>200,000
Very far above normal	>1000	400					
Far above normal	10-1000	100-400	Daytime	10 -100	100		
Slightly above normal	1-10	20-100	Nighttime	1-10	100		
Within normal	<1	<20	Sensitive	0.1-10	30		

exposed to non-thermal RF from mobile communication.”
[Markov 2013].

Bioeffects and health impacts observed at low-intensity radiation have induced many countries, regions and

organizations to adopt protection at levels lower than the thermal (ICNIRP) thresholds, planning targets or interim environmental action levels.

About half of the world (Russia, Italy, Switzerland) is limiting levels of radiation to values much lower than the thermal levels of Canada and the US.

The disparity of opinions in relation to Power Density limits for the protection of human health have therefore expanded beyond those described in 1960 (5.3.1), as seen in the tables below.

In a first group of countries, thermal recommendations are binding national legislation: Cyprus, Czech Republic, Estonia, Finland, France, Hungary, Ireland, Malta, Portugal, Romania and Spain. The Spanish region of Catalonia has stricter regulation than the federal government. In Germany and Slovakia, the thermal levels have become de facto exposure limits.

In a second group of countries, limits based on thermal are not binding, there are more lenient limits, or there is no regulation: Austria, Denmark, Latvia, Netherlands, Sweden and United Kingdom.

In a third group of countries, there are *stricter* restrictions than thermal, based on the precautionary principle, sometimes based on the principle of “as low as reasonably achievable without endangering service”.

Landmarks and Limits	$\mu\text{W}/\text{m}^2$
Natural Cosmic MW Radiation	<0.000001
Minimum Signal for a Radio Receiver or Cell Phone	0.000027
Baubiology, Nighttime	0.1
Austrian Medical Association, Hyper-Sensitives	< 1
Parliamentary Assembly of the Council of Europe, 2011 (inside limit, future target)	100
Salzburg Resolution 2000, Bioinitiative Report 2012 [Bioinitiative, 2012], Parliamentary Assembly of the Council of Europe, 2011 (inside limit)	1000
Start of Permeability Loss of Blood-Brain Barrier	4,000
Ecolog 2000	10,000
30 cm from Smart Meter emitting 1% of the time, with reflection	22,000
Switzerland, Russia, Italy, Poland, and Salzburg Resolution (2000)	100,000
Inhibition of DNA Repair in Stem Cells	920,000
Belgium	1,200,000
At 30 cm from Smart Meter emitting 100% of the time, with reflection	2,200,000
Code 6, Canada; IEEE C96.1; Germany, England, Finland, Japan	10,000,000

Belgium: Flemish legislation limits the electrical field strength per antenna for telecommunication to 7% of the thermal level in places of stay like homes, schools, rest homes and nurseries. The maximum exposure per location is 50% of the thermal level for frequencies 10 MHz-10 GHz. The Brussels Region limits total exposure in residences for frequencies 100 kHz- 300 GHz to a power density of 0.5% of the thermal (corresponding with 7% for the E field strength). For the same frequency range, Wallonia sets a fixed limit for the E field strength per antenna in residences which is 7% of the thermal level at 900 Hz.

Bulgaria: limits for power density are 2% of thermal at 900 MHz and less than 2% for higher frequencies.

Greece: 70% of those in thermal and 60% when antenna stations are located closer than 300 meters from the property boundaries of schools, kindergartens, hospitals or eldercare facilities. Installation of mobile phone antenna stations is not allowed within the property boundaries of aforementioned facilities.

Italy: Under Italian law, ICIRP levels have become *de facto* exposure limits. In contrast with the limits of thermal, these are fixed (not frequency dependent) between 3 MHz- 3 GHz. The limit for B field strength at 900 MHz is 45% of the thermal level (22% for power density). In homes, schools, playgrounds and places where people may stay for longer than 4 hours, an “attention value” for B field applies that is 14% of the thermal level at 900 MHz (2% for power density).

The “quality goal” for new installations is identical to the attention value.

Lithuania: There are fixed limits for power density at frequencies 300 MHz-300 GHz. The limit is 2% of the thermal level at 900 MHz and less than 2% for higher frequencies.

Luxembourg: Precautionary policy applies to mobile telephony through a law on classified locations and technical standards. These set a fixed exposure limit for the E field strength of 3 volt per meter per antenna which is 7% of the thermal level at 900 Hz. The limit for the total number of antennas in one location equals the thermal reference level.

Poland: In locations that are accessible to the public, frequency-dependent exposure limits lower than thermal are set for E field strength and power density. At 900 MHz the limit for E field strength is 17% of thermal level (2% for power density).

Slovenia: For frequencies higher than 10 kHz, exposure limits for E and B field strength to 31% of the thermal levels (10% for power density) apply in “sensitive areas” (homes, schools, hospitals etc.). In all other locations the thermal levels are applied.

Spain: The Spanish autonomic region of Catalonia has exposure limits for E and B field strength that are 65% of those in thermal (44% for power density) and minimal distances to antennas.

Australia's radiation protection standard are identical to those in thermal.

In **Russia**, general conditions for protection of the population are set in a 1999 framework law. Limits for specific frequency ranges are set in subsequent “Hygienic-epidemiological requirements”. The exposure limit for power density for EMR between 300 MHz-300 GHz is 2% of the thermal levels. The reason is to prevent biological effects that are not generally seen as a health risks in Western countries.

In **Switzerland**, an ordinance on non-ionizing radiation is in force since 2000. Mandatory exposure limits identical to the thermal levels apply in all areas accessible to the public. A stricter, precautionary limit for the E field strength of 10% of thermal applies to mobile phone masts. A frequency-dependent exposure limit for E field strength of 11% to 3% of the thermal level applies to other transmitters and to radar.

United States sets basic restrictions identical to thermal.

China's restrictions are analyzed here [Peipe, 2016].

Most toxic agents have multiple effects. Toxicology traditionally aims to find the *Critical Variable* (the particular health effect) that should determine the acceptable human exposure. This materializes in terms of determinations of the NOEL (No Observed Effect Level) and NOAEL (No Observed Adverse Effect Level). The No Observed Effect Level for

EMR is approximately 0. What is *adverse* then becomes pivotal.

A significant expansion of assessment problems comes from the role of time in revealing toxicity. In other words, is suppression of a relatively acute action, such as alteration of the blood-brain barrier at $4,000 \mu\text{W}/\text{m}^2$, sufficient to defend the organism against all other possible risks, such as cancer and chronic neurological diseases as well as EHS?

Because of a strong engineering tradition in electromagnetism, there has been undue emphasis on carrier frequency and power of EMR signals, as opposed to the more important and physiologically relevant modulation (GSM vs CDMA) and time-course of exposures. There is a real possibility of unusual dose-responses, and frequency or modulation specificities. The large range of opinions on appropriate measures of protection (5.5.1) results from an inter-disciplinary problem: specialists ignore other sciences, leading to the deployment of engineering solutions that unnecessarily imperil human health.

5.5.2. Protection against Heat

In 1975, it was observed that rats stopped working for food when exposed to 4 W/kg of MW radiation. With a safety factor of 10, the thermal standard was set to limit the average whole body SAR to a value of 0.4 W/kg between 1 MHz-300 GHz. Effects were reported at that time at least an order of magnitude below 4 W/kg, but were labeled *inconsistent*.

Unfortunately for this kind of risk limit, recent studies [Deshmukh 2016] on male Fischer rats over 90 days show that SARs of 0.0006 W/kg lead to hazardous effects on the brain, based on tests for cognitive function. HSP70 levels were elevated, as well as DNA damage as assessed by alkaline Comet assay.

US research groups [Oscar 1977; Albert 1979] indicated increased permeation of the blood-brain barrier at power levels 1/3 to 1/50 of the thermal standard. Dutta et al. [1989] reported changes in calcium metabolism in cells exposed to 0.05-0.005 W/kg. Ray and Behari [1990] reported a decrease in eating and drinking behavior in rats exposed to 0.0317 W/kg. Kwee and Raskmark [1997] reported changes in cell proliferation at SARs of 0.000021- 0.0021 W/kg. Phillips et al. [1998] observed DNA damage at 0.024-0.0024 W/kg.

Chronically exposed rats even showed increases in primary malignant tumors at exposures (2.45 GHz) half of the limit.

Instead of recognizing that the agent was incompletely understood, and to use caution, the human limit was so set an order of magnitude below the *least controversial* of the effects in animals. It is therefore based on a tolerable increase of body temperature corresponding to about 5 times the heat produced by basal metabolism. This in itself is a highly contentious position, as the body is not set to compensate an artificial extraneous agent such as MWs. By relying on absence of ionization capability of MWs as an argument, and by restricting the region-of-scientific-interest exclusively to heat, standard setters only showed a desire to remove all precautions in the deployment of EMR-based commercial and military applications.

The thermally inspired standard has to coordinate a number of interacting factors to limit temperature rises in the body.

✚ Since the SAR is **proportional to frequency** (5.4.6), the limits generally decrease with frequency to compensate, taking also changes in dielectric properties of biological tissue with frequency into account.

- ✦ The SAR is maximal when the long axis of a body is parallel to the electric field vector, and is 0.4 times the wavelength of the incident field. Therefore, **the maximum whole-body resonance for humans 1.75 m tall occurs at 70 MHz**, which is reflected in the thermal standard having its lowest point (central notch) near that value (red circle).
- ✦ **Exposure duration** is integrated over 6 minutes, reflecting thermal averaging by the body. For exposures less than 6 minutes, the table below lists the increase in the power density level which is tolerated. Extremely short exposures would allow practically unlimited field exposures.

Thermal limits show separate exposures for E and B fields up to hundreds of MHz, but beyond, only a Power Density limit is illustrated. This speaks to the physical coupling between the two fields at higher frequencies, as a single value of Power Density limits both fields.

IEEE C95.1 is only a *recommendation*, but industry was quick to adopt it, particularly in telecommunications (broadcasting and wireless), because it gave practically unlimited leeway for technical applications.

5.5.3. Restricted Scope of Government Guidelines based on Heat

1. Thermal standards are limited in scope to **short-term heating**.
2. The **set of technical publications** considered relevant to standard setting is deliberately narrowed by industry-influenced reviewers.
3. Thermal standards implement **low-power exemptions** to favor commercialization of portable communications units.

“For example, if a device functioning between 10 kHz and 1 GHz has an output power of 7 W or less, it is excluded from any further probing.”

4. *“The standard can also be satisfied if it can be demonstrated that an SAR of less than 0.4 W/kg averaged over the whole body, and peak spatial SARs of less than 8 W/kg over any gram of tissue are produced.”*

A biologist would struggle with the notion that there is anything special about **a gram of tissue**.

5. Thermal standards accept higher limits for **partial-body exposures**. The arms are sometimes highly exposed, because of the handling of parts in industrial processes (dielectric heaters), and the ears are pressed against cellular phones. According to the thermal standard, an *extremity* can tolerate more radiation. This is not compatible with basic physiology, as vulnerable cells are present everywhere in the body. When improved computations showed that the ear was irradiated over the SAR limits, C95.1 simply reclassified it as an “extremity” and averaged exposure over 10 g, as opposed to 1 g. C95.1 changed limits in relation to engineering needs, and adjustments are made to human sensitivity rather than to hardware.

6. **Pulsed exposures**, which are biologically more active, are essentially considered only in terms of their heat content. SAR (W/kg) averaged over 6 or 30 minutes are totally insensitive to crest values of induced electric or magnetic fields in tissues. This shows an unwillingness to tackle the full complexity of EMR interactions. The time variation of EMR, the various codecs and keying techniques that allow the inclusion of analog and digital data onto EMR carriers, are ignored by C95.1, lost within the SAR bubble.

This is particularly troublesome, given that industry designs communications codecs much faster than toxicologists can assess them. Ignoring the pulsative nature of telecommunications signals in assessing their biological activity is incompatible with good science and the demonstrated effectiveness of bone regeneration applications (Chap. 3, Appendix 3).

5.5.4. Canadian Guidelines

Canada's Code 6 follows thermal levels.

<https://www.canada.ca/en/health-canada/services/environmental-workplace-health/reports-publications/radiation/safety-code-6-health-canada-radiofrequency-exposure-guidelines-environmental-workplace-health-health-canada.html>

Fields and Power Density

Show that an electric field of 0.614 kV/m translates to a Power Density Level of 1,000 W/m²

$$E = 0.614 \text{ kV/m} = 614 \text{ V/m}$$

$$E^2 = 376,996 \text{ V}^2/\text{m}^2$$

$$E^2 / 377 = 376,996 / 377 = 1000 \text{ W/m}^2$$

$$1000 \text{ W/m}^2 = 100 \text{ mW/cm}^2$$

Show that a magnetic field of 0.205 μT translates to a Power Density Level of 10 W/m²

$$B = 0.205 \text{ μT}$$

$$B^2 = (0.205 \times 0.796)^2 = 0.0266 \text{ A}^2/\text{m}^2$$

$$B^2 \times 377 = 10 \text{ W/m}^2 = 1 \text{ mW/cm}^2$$

Problem 56. What is the free space power density, in mW/cm², of a 2,450 MHz EMR whose maximum instantaneous electric field intensity is 100 mV/m? What is the maximum magnetic intensity in the wave?

5.6. Control Measures

The hygienist is responsible for:

- ✦ establishing equipment safe operation procedures,
- ✦ ensuring that all workers are aware of potential dangers,
- ✦ posting warning signs and designating areas as controlled, with locks and interlocks if necessary,
- ✦ radiation surveys record keeping,
- ✦ acting on reports of over-exposures,
- ✦ keeping track of exposures, and minimizing them whenever possible,
- ✦ removing unnecessary metallic objects from the vicinity of EMR sources,
- ✦ restricting the radiation pattern of antennas to appropriate directions.

5.6.1. Shielding

Given a source of EMR, the simplest protection is to move away. This strategy is often the only one left to EHS individuals. If this cannot be done, the problem of either enclosing the source, or shielding the person or residence can become complex. The reason is that EMR covers a wide range of frequencies, and that intuitive measures can be made ineffective by electrical parasites such as inductance and capacitance. EM noise can propagate through wires, or by radiation through the air.

5.6.1.1. Electric Shielding

Although shielding could in principle be a very effective technique for controlling sources of EMR, its practical effectiveness is often limited because the sources cannot be completely enclosed without interfering with their purpose.



One effective method is the use of cables instead of wires, because cables can be built to leak very low levels of radiation (4.7.1.3). Beyond cables, the electric field can nonetheless economically be reduced in some applications. Shielding against EMR can be cheaply obtained using *closed metallic enclosures* of **any metal** [Kalanjati 2019]. In an ideal case, reductions of as much as **100 dB** can be obtained. However, cost-cutting has led many manufacturers to substitute metal housings for leaky plastic ones. Practical situations are usually complex: a completely closed enclosure is usually not possible, and a form of reflector is often the only alternative (for example, for windows). When shielding or grounding against high frequencies, the current return path of the shield must be of suitably *low inductance* in order to be effective (otherwise, the shielding may become a *secondary radiator*). Calculated resistances using properties of the bulk of the metal are often inadequate at high frequencies, because of the *skin effect*.¹⁵

¹⁵ The phenomenon is simply a reflection of the *mutual inductance* of the currents circulating in a conductor, which tends to push them away from one another. This results in most of the *current traveling on the surface of the conductors, rather than evenly spread throughout their bulk*, hence a higher impedance is obtained, and shielding much less effective.

When possible, absorbing (water) rather than reflective (metal) shielding material should be used, particularly if the shielded area includes an operator.

To protect against electrical shocks specifically, the replacement of metallic parts with non-conductive materials should be considered as an effective method of reducing both fields and contact currents in certain situations.

5.6.1.2. Magnetic Shielding

Magnetic shielding is fundamentally more difficult to implement than *electric shielding*. There are two techniques generally in use. **The simplest one is to construct metallic cavities of very low electrical resistance** (i.e. copper) that enclose the radiating object. The magnetic field will induce in the enclosure electric currents which will counteract the magnetic field exciting it. This counter-action is widely known as **Lenz's Law**.

The second method (applied mostly at low frequencies) uses **magnetic metals** to restrict the spatial extension of the incident magnetic field. Certain alloys such as *mu-metal*, *co-permalloy* or *supermalloy* have high magnetic permeabilities, which allows them to concentrate magnetic field lines within their volume, rather than letting them escape into the surrounding space. *Supermalloy* has a magnetic permeability as high as 100,000, and very low **coercitivity**, which means that it will concentrate even very low field values.



When the magnetic radiation to be confined are radio or MW frequencies, however, the *magnetic metals become ineffective*.

Special ferrites tuned to specific frequencies can be used, and the highly conductive shielding structures (i.e. copper) must then conform to very low inductance and resistivity to be successful.

5.6.2. Enclosing Equipment

A specialized box designed specifically for EMR shielding and built from 14 gauge steel with special

rolled lips on all door sides and EMR gaskets can offer the following performance: greater than 95 dB at 14.5 kHz to greater than 100 dB at 1 MHz for magnetic fields, and greater than 100 dB from 14.5 kHz to 430



MHz for electric fields. Such good performance is related to the thickness of steel, highly conductive non-corrosive path from cover to enclosure, and total absence of holes for radiation leakage.

Boxes specific for computer shielding are available at <https://argonautenclosures.com>.

5.6.3. Personal Shielding

Simple protective gloves can be used to insulate workers against contact currents from conductive surfaces (resulting in shocks) in EMR fields. Safe conditions may be established by eliminating large metallic objects.

For radiation impinging directly on the body, protective clothing and eye shields have been developed. Their use should be surrounded with caution. Discontinuities in the clothing or

in the fitting can result in secondary sources to actually increase the hazard to the wearer. Chou [1986] tested a protective suit designed to attenuate MWs. The suit, a mixture of Nomex III and metal fibers, is well ventilated and fire retardant. The attenuations measured for the fabric were 35-40 dB for the frequency range 1.5-11 GHz, and 28-35 dB for the frequency range 0.65-1.15 GHz. The complete suit had (average of 10 locations) 25 dB attenuation at 2450 MHz, and 20 dB at 915 MHz.

5.6.4. Increasing Distance

In many instances, *distance between the personnel and the radiating sources can be used to improve hygiene conditions.* The devices should be located as far away as possible from the operator and from other workers. In such instances, the use of a **radiation meter** is useful to find, within the field, the **most adequate position for the operator**. There should be no unnecessary metallic objects near radiating devices, as these may enhance fields and increase the chance of EMR shocks and burns (these may result from fields of approximately 615 V/m or 1,000,000,000 $\mu\text{W}/\text{m}^2$ in the frequency band 0.3 to 3 MHz).

5.6.5. Controlled Areas

Certain locations should have warning signs (shown below) with short exposure recommendations whenever possible. Interlocks to certain accessible spaces should set in such a way that EMR devices cannot be operated when the door is open. It should always be possible to open the door from inside the room, and workers should be positively warned to escape if the source is turned on.



DANGER RADIO FREQUENCY RADIATION
Serious Hazard
Critical injury or death possible from misuse
Area of denied occupancy



WARNING RADIO FREQUENCY RADIATION
Moderate Hazard
Serious injury possible from misuse
Area of limited occupancy



CAUTION RADIO FREQUENCY RADIATION
Negligible Hazard
Minor injury possible from misuse
Area of unrestricted occupancy

In the vicinity of powerful telecommunications emitters, it is suggested that access be limited. Emitters are often placed on top of mountains or skyscrapers. Adjoining terrain can be fenced off, adjoining buildings should be assessed for radiation levels in the case of skyscrapers.

Arcing can happen in high power fields. Strong fields can induce dangerous voltages in unrelated metallic structures, especially at some resonance frequencies. Such fields can then give rise to sparks, a significant danger in the use of explosives or flammable substances.

5.6.6. Worker Training

Personnel working with EMR devices should receive **periodic training in safe operation methods**. Specific control measures may include: *mapping out of unsafe areas, posting of warning signs, establishing procedures for excluding unauthorized personnel, excluding persons from unsafe areas, installing shielding and interlocks, providing protective equipment, establishing MW monitoring or measurement sessions, and maintaining strong supervisory influence over MW operations.*

5.6.7. Medical Monitoring

In many countries, initial and periodic medical examinations of EMR workers are a legal requirement. Such evaluations include **physical examination, hematology and urinalysis, and sometimes a chest X-ray**. Poland is one of the countries which require more specific examinations for workers using EMR energy. Such procedures may include **electrocardiography, neurological examination with electroencephalography, and ophthalmological examination using a slit lamp**.

In Czechoslovakia, Poland and the USSR, medical examination may be used to identify people who should not work with EMR. Contraindications include neoplasia, hematopoietic system disorders, organic or pronounced neurological disturbances, and endocrine disorders. When blood diseases and gastroduodenal ulcers occur, workers may be temporarily shifted to other duties. When special examinations are planned for workers exposed to EMR, special attention should be paid to defining who is exposed. *In Poland and in the USSR, a number of specific health conditions in workers occupationally exposed to EMR are recognized as occupational diseases, and the diagnosis of such a condition leads to compensation.*

5.6.8. Safety Procedures

5.6.8.1. Children in Schools

Children are potentially more vulnerable to EMR fields, because of the greater susceptibility of their developing nervous system, and of the superior conductivity of their brain tissue (it has a higher water content and ion concentration than adult tissue). As a consequence, EMR penetration is greater relative to head size, and children have greater absorption of EMR energy in the tissues of the head at mobile telephone frequencies. Young children will also bear a longer lifetime exposure [Moon 2020].

Russian scientists are warning countries throughout the world including ministries of health and other organizations responsible for population safety (including children), to require the use of wired networks in schools and educational institutions, rather than a network using wireless broadband systems, including Wi-Fi.

Desktop computers, laptops, notebooks, and tablets should be operated on a desk; operation of these devices on an occupant's lap or body is prohibited; computer workstation equipment must be greater than 60 cm from occupants.

Desktop computers, laptops, notebooks, and tablets should be TCO-certified or laboratory tested to meet TCO Criteria "Mandate A.4.2" for EMR emissions.

Laptops or notebooks have an Ethernet port and a physical switch to conveniently disable all wireless radios at once and an adaptor with a 3-pin plug.

Only tablets that support a USB Ethernet adaptor for a wired network connection; operate tablets only in battery mode and not when plugged in.

Install a **wired** local area network (LAN) for Internet access throughout schools. Provide wired network connections for desktop computers, laptops, notebooks, and tablets. All wireless transmitters shall be disabled on all Wi-Fi-enabled devices. Provide wired input devices for computer workstations.

Install easily accessible hard-wired phones for teacher and student use, and prohibit installation and use of DECT cordless phones and cordless phones operating at 2.4 GHz and 5.8 GHz, unless they have been laboratory tested to demonstrate that the cordless phone base station and handsets (whether placed in the charging station or not) do not emit EMR in standby mode.

These precautions are in great part linked to reports of impaired learning and Attention Deficit Hyperactivity Disorder (ADHD)

as a result of proliferation of WiFi in schools [Byun 2013; Narayanan 2018a; Sage 2018; Lena 2017; Choi 2017; Yan 2017; Ramirez-Vasquez 2020].

5.6.8.2. Cellular Phones

Russian authorities urge pregnant women to avoid mobile phones and WiFi entirely, along with children under eighteen. Likewise, Germany, India, the United Kingdom, Israel, Finland, Belgium and Toronto, Canada, have issued health warnings for children not to use mobile phones.

Prohibit the use of cell phones and other personal electronic devices in instructional areas / classrooms. Additionally, they shall be required to be powered off or be in airplane mode (sleep mode is not sufficient) except during fire-life-safety drills and incidents.

- 1. Use a headset.** Air tubes are best. Keep the phone's antenna away from your head and body. Shields that claim to reduce exposure generally don't work as advertised.
- 2. Limit use by children and teens.** Encourage them to wear a headset or to send text messages (that keeps the phone away from the head).
- 3. Use the phone sparingly.** Cellular Phones are a convenience, not a necessity.
- 4. Driving.** If you need to use a phone while in a vehicle, pull off to where it's safe.

5.6.8.3. Radars

In the case of radars, antenna sweep restrictions should be considered to reduce human exposure. Maintenance workers repairing wave guides or feed cables to antennas should be made aware of the dangers. Mobile and transportable systems should have with them warning signs and instructions for safe use.

5.6.8.4. Dielectric Heaters

This category of devices presents appreciable risks to the operator. The risks can usually be eliminated by improved design, change in operator position or addition of shielding.

The **control console can be moved away from the applicator**. The volume where heat is applied should be shielded using thin, flexible metal sheets or straps that close the remaining open gap during EMR power applications. Indicators showing that power is on should be clearly visible. Operators should be informed of the dangers. A sewing



machine-type dielectric heater is likely to generate high exposures. In some cases, when workers must be close to the apparatus, exposure can be reduced by enclosing the volume of heat application, but also by insuring that **different parts of a given machine are correctly grounded**. The designers have not always insured that stable electric contacts between different parts of the apparatus

prevent them from becoming secondary radiators, which can contribute to exposure, particularly when wear and dirt between moving parts is considered. The grounding connections must be short and stout to be effective (length smaller than wavelength/10).

5.6.8.5. Microwave and Short-Wave Diathermy

Cables and electrodes should be checked periodically for burns and cracks. Exposure tests should be performed under load (saline solution). In placement of the electrode, minimize the

gap between electrodes and the part to be treated, so as to limit stray radiation. Apply power only after all contacts are made. All metal objects should be kept at least 3 m away from the electrodes.

Hygiene Measurements of Contact Current: if contact currents are a problem, it is generally necessary for a measurement to be performed. This is done using a special *standing plate* placed on the floor. The worker (or an equivalent resistance) stands on the plate, and accomplishes the contact maneuvers. A device in the plate (thermocouple, voltmeter or current transformer) is used to monitor the current resulting from the contact.

5.6.8.6. Protecting Explosives

Electric blasting caps and electric squibs used to trigger dynamite can be ignited in the presence of radio transmitters or other EMR fields. So, radio transmitters can represent a hazard in this context. Refer to CSA standard Z65, *Radiation Hazards from Electronic Equipment*. Under certain circumstances, electrical wires connected to blasting caps can pickup sufficient EMR energy to trigger explosions. Sensitivity depends on frequency (lower frequencies are more dangerous), on the polarization and intensity of the field, as well as specific properties of the blasting caps, including the way they are shielded against radio interference.

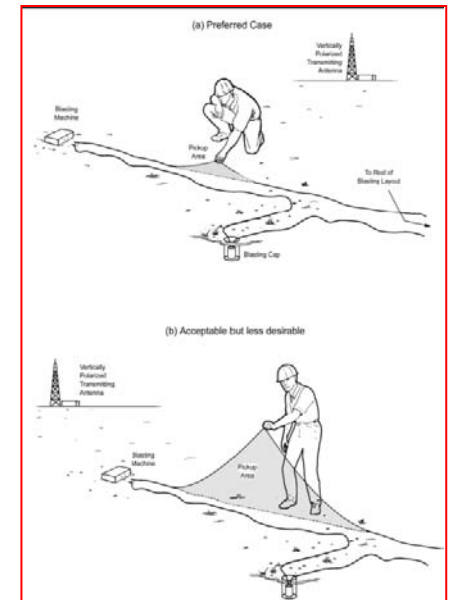

Hazards from spurious explosion of **blasting caps** due to external EMR (broadcast antennas, electric storms) can occur at levels substantially below those thermally dangerous to human health. Powers higher than 40 mW applied to the cap present a potential danger. The wiring to the blasting cap will be the receiving structure, acting to gather the EMR energy. The connections can be modeled either as dipoles or as loop antennas. In this second case, it is important to minimize the loop area (illustrated) to reduce the energy gathered.

In any procedure, the caps should be connected to the wiring last. Tables are available to estimate the safe distance for any type of transmitter.

Problem 57. A survey of dielectric heaters in Canada conducted in 1980 concluded that some of the devices may pose a health hazard from over-exposure to high intensity EMR fields. The devices investigated included the following types: sewing machine, shuttle tray, turntable, pressure-sealed applicator and edge-glue dryer. One of those device types exposed the workers to levels above 10 W/m² in more than half of the machines investigated and to levels above 100 W/m² in almost 40% of the cases. Which of the devices above produced these exceptionally intense exposures?

Problem 58. A worker exposed to whole-body 2.54 GHz radiation is exactly at the standard limit taking into account the duty cycle of 1 minute “on”, 59 minutes “off”. Calculate the “on” RMS electric field value that you expect to find at the worker’s position, using the plane wave assumption.

5.6.9. Improving Data Transmission Techniques

5.6.9.1. Switching Off

Many systems designed by telecommunications engineers emit radiation even when not activated by users [Swisscom 2003]. This stems from a philosophy of simplifying design, coupled

with the erroneous belief that radiation is of no consequence to health. All systems should be designed to go on standby when not in use, to transmit only essential data, and coverage does not have to be complete for all applications. Intelligent systems can de-activate locations completely at appropriate times. Even while conserving the data rate, some routers can minimize user exposure by emitting fewer pulses (<https://www.jrselectrohealth.com/pcat/low-radiation-wifi-routers-jrs-eco-wifi/>).

5.6.9.2. Better Cables

Fiber optic or cable connections should be preferred whenever possible. In the case of cabled data connections (Internet wiring), high performance shielding is available as higher category cables (see table below).

Designation	Bandwidth	Application	Comment
Level 1	0.4 MHz	Telephone and modem lines	Not described in EIA/TIA recommendations. Unsuitable for modern systems.
Level 2	4 MHz	Older terminal systems, e.g. IBM 3270	Not described in EIA/TIA recommendations. Unsuitable for modern systems.
Cat 3	16 MHz	10BASE-T and 100BASE-T4 Ethernet[10]	Described in EIA/TIA-568. Unsuitable for speeds above 16 Mbit/s. Now mainly for telephone cables.
Cat 4	20 MHz	16 Mbit/s[10] Token Ring	Not commonly used.
Cat 5	100 MHz	100BASE-TX & 1000BASE-T Ethernet[10]	Common for current LANs. Superseded by Cat5e, but most Cat5 cable meets Cat5e standards.
Cat 5e	100 MHz	100BASE-TX & 1000BASE-T Ethernet[10]	Enhanced Cat5. Common for current LANs. Same construction as Cat5, but with better testing standards.
Cat 6	250 MHz	10GBASE-T Ethernet	ISO/IEC 11801 2nd Ed. (2002), ANSI/TIA 568-B.2-1.
Cat 6A F/UTP,	500 MHz	10GBASE-T Ethernet	Adds cable shielding. ISO/IEC 11801 2nd Ed. Am. 2. (2008),

U/FTP			ANSI/TIA-568-C.1 (2009)
Cat 7 S/FTP, F/FTP	600 MHz	10GBASE-T Ethernet or POTS/CATV/1000BASE-T over single cable	Fully shielded cable. ISO/IEC 11801 2nd Ed. (2002)
Cat 7A S/FTP, F/FTP	1000 MHz	10GBASE-T Ethernet or POTS/CATV/1000BASE-T over single cable	Uses all four pairs. ISO/IEC 11801 2nd Ed. Am. 2. (2008)

Yellow: Unshielded Twisted Pairs, Foil/Unshielded Twisted Pair, Unshielded/Foil Twisted Pair, S-braided/Foil Twisted Pair, Foil/Foil Twisted Pair

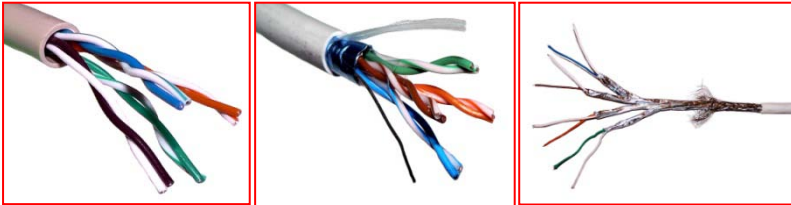

5.6.9.3. Li-Fi

Beyond WiFi, Li-Fi [Haas 2018] can deliver internet access 100 times faster, having already demonstrated speeds of up to 1Gbps (gigabit per second). This technique can eliminate the problems associated with the poor penetration and speed of 5G by using interior lighting in buildings as transmitters.

It requires a light source, such as a LED bulb [Philips 2019], an internet connection and a photo detector. Laboratory tests have shown theoretical speeds of up to 224 Gbps [BBC 2015]. Li-Fi does not interfere with radio signals, so could be utilized on aircraft and in other places where interference is an issue.

While the spectrum for EMR is in short supply, the visible light spectrum is 10,000 times larger, meaning it is unlikely to run out any time soon. But it is harder to deploy outdoors in direct sunlight.

Since Li-Fi uses EMR that humans have evolved with, it is much less likely to involve pathologic biological effects.

5.6.9.4. Project Loon

Google's plan to launch "Project Loon" would cover 96.1% of the US with balloons 19 kilometers above the earth to provide Internet to subscribers. A balloon would have multiple transmitters, possibly as small as 2 mm in size, beaming targeted EMR to a subscriber in a circle of roughly 100 meters. The transmissions would be at 71 and 81 GHz, LTE (4G), with a signal strength equivalent to $200 \mu\text{W}/\text{m}^2$ at ground level. This signal is much smaller than our current exposures, but it is too high for an EHS person.

5.7. Summary

On-going research on EMR health effects revolves around chronic diseases such as cancer, neurological diseases, fertility and metabolism. Because of basic difficulties in the biological definition of exposures and in measurements, the science of EMR health effects is still primitive, mostly based on the relations between average powers and a large number of biological variables.

Penetration depth of the fields into biological tissues tends to decrease with frequency. While using probes to assess fields with either broad or narrow-band instruments, one should be careful of having proper frequency sensitivity and of near-field effects. Antennas come in various types, with different irradiation patterns.

There are many industrial applications of EMR for heating, melting, welding and telecommunications, and in those industries, thermal over-exposures are known to be fairly common. Long-term operation of cellular phones carries a risk of brain, and probably other cancers. In view of the expected proliferation of wireless devices in the next decades, the importance of the present health assessment process is obvious.

Thermal standards of EMR exposure, under industry influence, have evolved little for about 30 years, to protect established techniques and avoid legal liability.

Classical methods such as control at the source, reduction of transmission and shielding, as well as administrative controls are all applicable. The dual role of the hygienist is to protect subjects from thermal risks but also from the chronic risks that occur at much lower field intensities. Attaining adequate protection may require extensive revisions of engineering methods.

When it comes to adequately protecting human health, standardization committees, particularly in the West, have been shown to ignore the contributions of biologists and health professionals in order to expedite the commercial deployment of various systems, although alternate and feasible engineering techniques were available for protection. The result is that electrical devices on the market that are compatible with higher standards of human health are presently difficult to come by.

5.8. Bibliography

Adams 1986. Biologic Effects And Potential Hazards Of Nuclear Magnetic Imaging. *Cardiovasc Intervent Radiol* 8(5/6):260-263.

Adams 2014. Effect of mobile telephones on sperm quality: A systematic review and meta-analysis. *Environ Int.* 2014 Sep;70:106-12. doi: 10.1016/j.envint.2014.04.015.

Affuso 2018 et al. Wireless Towers and Home Values: An Alternative Valuation Approach Using a Spatial Econometric Analysis. *J Real Estate Finan Econ* (2018) 56:653–676. DOI 10.1007/s11146-017-9600-9.

Ahmadi 2018 et al. Exposure to GSM 900-MHz mobile radiation impaired inhibitory avoidance memory consolidation in rat: Involvements of opioidergic and nitrenergic systems. *Brain Research.* 1701:36-45. Dec 2018. <https://doi.org/10.1016/j.brainres.2018.07.016>.

Ahmed 2018 et al. The chronic effect of pulsed 1800 MHz electromagnetic radiation on amino acid neurotransmitters in three different areas of juvenile and young adult rat brain. *Toxicol Ind Health.* 2018 Oct 21:748233718798975. doi: 10.1177/0748233718798975.

Aitken 2005 et al. Impact of radio frequency electromagnetic radiation on DNA integrity in the male germline. *Inter. J. Androl.*28:171-179.

Albert 1977 et al. Morphologic Alterations In Hamster Blood-Brain Barrier After Microwave Irradiation (meeting abstract). *J Microw Power* 12(1):43-44

Albert 1981 et al. Effect Of Nonionizing Radiation On The Purkinje Cells Of The Rat Cerebellum. *BioElectromagnetics* 2(3):247-257

Altun 2018 et al. Effects of mobile phone exposure on metabolomics in the male and female reproductive systems. *Environmental Research.* Available online 5 June 2018.

Asghari 2016 et al. A review on Electromagnetic fields (EMFs) and the reproductive system. *Electron Physician.* 2016 Jul 25;8(7):2655-62. doi: 10.19082/2655.

Athey 1982 et al. Magnetic Fields Associated With A Nuclear Magnetic Resonance Medical Imaging System. *Magn Reson Imaging* 1(2):149-154.

Abramson 1960 et al. Changes in blood flow, oxygen uptake, and tissue temperatures produced by therapeutic physical agents. II. Effect of short-wave diathermy. *Am. J. Phys. Med.* 39:87.

Abramson 1957 et al. Changes in peripheral blood flow produced by short-wave diathermy. *Arch. Phys. Med.* 38:369.

Al-Bayyari 2017 . The effect of cell phone usage on semen quality and fertility among Jordanian males. *Middle East Fertility Society Journal.* Published online Apr 7, 2017. <http://doi.org/10.1016/j.mefs.2017.03.006>.

Albert 1979. Reversibility Of Microwave-Induced Blood-Brain Barrier Permeability. *Radio Science* 14: 323-327.

Alimohammadi 2018 et al. The effects of radiofrequency radiation on mice fetus weight, length and tissues. *Data Brief.* 2018 Jun 30;19:2189-2194. doi: 10.1016/j.dib.2018.06.107.

Al-Serori 2018 et al. Mobile phone specific electromagnetic fields induce transient DNA damage and nucleotide excision repair in serum-deprived human glioblastoma cells. *PLOS One.* April 12, 2018. <https://doi.org/10.1371/journal.pone.0193677>.

Aminzadeh 2018 et al. A Multi-Band Body-Worn Distributed Radio-Frequency Exposure Meter: Design, On-Body Calibration and Study of Body Morphology. *Sensors.* 18(1). Jan 2018.

Avendano 2012 et al. Use of laptop computers connected to internet through Wi-Fi decreases human sperm motility and increases sperm DNA fragmentation. *Fertility and Sterility Vol.* 97, No. 1, January 2012. doi:10.1016/j.fertnstert.2011.10.012.

Ayoub 2018 et al. Mobile Phone Base Station Tower Settings Adjacent to School Buildings: Impact on Students' Cognitive Health. *American Journal of Men's Health.* 1–6. DOI: 10.1177/1557988318816914.

Azimadeh 2019 et al. Alteration of testicular regulatory and functional molecules following long-time exposure to 900 MHz RFW emitted from BTS. *Andrologia.* 2019;51:e13372. DOI: 10.1111/and.13372.

Baby 2017 et al. The effect of electromagnetic radiation due to mobile phone use on thyroid function in medical students studying in a medical college in South India. *Indian J Endocr Metab* 2017;21:797-802.

Badizadegan 2019 et al. Radiofrequency Interference in the Clinical Laboratory Case Report and Review of the Literature. *Am J Clin Pathol* May 2019;151:522-528. DOI: 10.1093/AJCP/AQY174.

Balzano 1978 et al. Heating of biological tissues in the induction field of VHF portable radio transmitters. *IEEE Transactions on Vehicular Technology.* Vol VT-27, No 2, 51-56.

Balzano 1978a et al. Energy deposition in simulated human operators of 800-MHz portable transmitters. *IEEE Transactions on Vehicular Technology.* Vol VT-27, No 4, 174-181.

Baranski 1967. Badania biologicznych efektow swoistego oddzialywania mikrofal. Inspektorat Lotnictwa. Warsaw.

Bahreyni Tossi 2017 et al. Exposure to mobile phone (900-1800?MHz) during pregnancy: tissue oxidative stress after childbirth. *J Matern Fetal Neonatal Med.* 2017 Apr 23:1-6. doi: 10.1080/14767058.2017.1315657.

Barnes 2018 et al. Effects of time delays on biological feedback systems and electromagnetic field exposures. *Bioelectromagnetics.* 2018 Feb 19. doi: 10.1002/bem.22114.

- Barteri 2005** et al. Structural and kinetic effects of mobile phone microwaves on acetylcholinesterase activity. *Biophys Chem.* 113(3):245-253.
- Bassen 1997.** RF interference of medical devices by mobile communications transmitters. In *Mobile Communications Safety*, Chapman & Hall, 1997. ISBN 0 4120 75000 7.
- BBC 2015** News, Technology, 27 November 2015. <http://www.bbc.com/news/technology-34942685>[2016-11-06 17:53:08].
- Beason 2002** et al. Responses of neurons to an amplitude modulated microwave stimulus. *Neurosci Lett* 333(3):175-178.
- Bektas 2018** et al. Effects of mobile phone exposure on biochemical parameters of cord blood: A preliminary study. *Electromagn Biol Med.* 2018 Aug 29:1-8. doi: 10.1080/15368378.2018.1499033.
- Bellepomme 2020** et al. Electrohypersensitivity as a Newly Identified and Characterized Neurologic Pathological Disorder: How to Diagnose, Treat, and Prevent It. *Int. J. Mol. Sci.* 2020, 21, 1915; doi:10.3390/ijms21061915.
- Bellieni 2017** et al. Electromagnetic fields in neonatal incubators: the reasons for an alert. *J Matern Fetal Neonatal Med.* 2017 Oct 8:1-11. doi: 10.1080/14767058.2017.1390559. *Int. J. Mol. Sci.* 2020, 21, 1915; doi:10.3390/ijms21061915.
- Bhatt 2015** CR. Radiofrequency-electromagnetic field exposures in kindergarten children. *Journal of Exposure Science and Environmental Epidemiology* (2016) 00, 1–8.
- Bhatt 2016** CR et al. Assessment of personal exposure from radiofrequency-electromagnetic fields in Australia and Belgium using on-body calibrated exposimeters. *Environ Res.* 2016 Nov;151:547-563. doi: 10.1016/j.envres.2016.08.022.
- Bilgici 2018** B et al. What is the adverse effect of Wireless Local Area Network, using 2.45 GHz, on the reproductive system? *Int J Radiat Biol.* 2018 Jul 20:1-25.
- Bini 1986** et al. Exposure Of Workers To Intense Rf Electric Fields That Leak From Plastic Sealers. *J Microw Power* 21(1):33-40.
- Bioinitiative 2012.** <http://www.bioinitiative.org/>
- Birks 2017** et al. Maternal cell phone use during pregnancy and child behavioral problems in five birth cohorts. *Environment International.* Published online April 7, 2017. <http://doi.org/10.1016/j.envint.2017.03.024>.
- Birks 2018** et al. Spatial and temporal variability of personal exposure to radio frequency electromagnetic fields in children in europe. *Occupational and Environmental Medicine* 75 (Suppl 1):A13.1-A13. March 2018. DOI: 10.1136/oemed-2018-ISEEabstracts.31.
- Brock 1978.** *Thermophilic Microorganisms and Life at High Temperatures*, Springer, New York.
- Brown-Woodman 1987** et al. Teratogenic effects of exposure to radiofrequency radiation from a shortwave diathermy unit. *Industrial Health* 26:1-10.
- Broom 2019** et al. Early-Life Exposure to Pulsed LTE Radiofrequency Fields Causes Persistent Changes in Activity and Behavior in C57BL/6 Jmice. *Bioelectromagnetics* 40:498--511 (2019).
- Budd 1985** . Can microwave/radiofrequency radiation (RFR) burns be distinguished from conventional burns? *J. Microwave Power* 20(1), 9-11.
- Buderi 1996.** The invention that changed the world: how a small group of radar pioneers won the second world war and alunched a technological revolution, S&S.
- Byun 2013** et al. Mobile phone use, blood lead levels, and attention deficit hyperactivity symptoms in children: a longitudinal study. *PLoS One.* 2013;8(3):e59742. doi: 10.1371/journal.pone.0059742.
- Canadian Center for Occupational Health and Safety 1989.** Effects of Microwaves on the Eye, Physical Hazards Group, Report P89-15E.
- Canadian Human Rights Commission 2007.** Table 2: International recognition of environmental sensitivities. Ottawa, ON: CHRC; 2007; Available from: http://www.chrc-ccdp.ca/research_program_recherche/esensitivites_hypersensibilitee/page3-eng.aspx.
- Carlberg 2014** et al. Decreased Survival of Glioma Patients with Astrocytoma Grade IV (Glioblastoma Multiforme) Associated with Long-Term Use of Mobile and Cordless Phones. *Int. J. Environ. Res. Public Health* 2014, 11(10), 10790-10805; doi:10.3390/ijerph111010790.
- Carlberg 2016** et al. Increasing incidence of thyroid cancer in the Nordic countries with main focus on Swedish data. *BMC Cancer* (2016) 16:426 DOI 10.1186/s12885-016-2429-4.
- Çelik 2016** O et al. Oxidative stress of brain and liver is increased by Wi-Fi (2.45GHz) exposure of rats during pregnancy and the development of newborns. *J Chem Neuroanat.* 2016 Sep;75(Pt B):134-9. doi: 10.1016/j.jchemneu.2015.10.005. Epub 2015 Oct 28.
- Chaitanya 2014** et al. Neuronal and astrocytic interactions modulate brain endothelial properties during metabolic stresses of in vitro cerebral ischemia. *Cell Communication and Signaling* 2014, 12:7 <http://www.biosignaling.com/content/12/1/7>.
- Chang 1982** et al. The Effect Of Microwave Radiation (1.0 Ghz) On The Blood-Brain Barrier In Dogs. *Radio Sci* 17(5S):165S-168S.
- Chatterjee 1985** et al. Quantification Of EM Absorption In Humans From Body Mounted Communication Transceivers. *IEEE Trans Vehicular Tech* 34(2):55-62.
- Chiang 1986** et al. Influence Of Environmental Emf On The Health Of Youth, Juvenile And Children (meeting abstract). *BioElectromagnetics Society, 8th Annual Meeting*, 1-5 June 1986, Madison, WI, p. 77.
- Chicago Tribune 2019.** <https://www.chicagotribune.com/investigations/ct-cell-phone-radiation-testing-20190821-72qu4nzlfda5kyuhteieih4da-story.html> .
- Choi 2017** KH et al. Neurodevelopment for the first three years following prenatal mobile phone use, radio frequency radiation and lead exposure. *Environmental Research*, 156:810-817, July 2017.
- Choi 2020** et al. Cellular Phone Use and Risk of Tumors: Systematic Review and Meta-Analysis. *Int. J. Environ. Res. Public Health* 2020, 17, 8079; doi:10.3390/ijerph17218079.
- Chou 1986** CK et al. Shielding Effectiveness Of A Microwave-Protective Suit (meeting abstract). *BioElectromagnetics Society, 8th Annual Meeting*, 1-5 June 1986, Madison, WI, p. 35.
- Chou 1992** CK et al. Long-term, low-level microwave irradiation of rats. *Bioelectromagnetics.* 1992;13(6):469-96.
- Chudnovskii 1979** VS. Psychoses In Radio Wave Disease. *Sov Med* (8):111-115.
- Cleveland 1989** RF Jr, et al. Specific Absorption Rate (SAR) in models of the human head exposed to hand-held UHF portable radios. *BioElectromagnetics* 10(2):173-186.
- Conover 1986** DL et al. Magnetic Field Measurements Near RF Induction Heaters. *BioElectromagnetics* 7(1):83-90.
- Cooper 2002** TG. Occupational Exposure to Electric and Magnetic Fields in the context of the ICNIRP guidelines. National Radiological Protection Board, 2002.
- D'Silva 2017** MH et al. Effect of Radiofrequency Radiation Emitted from 2G and 3G Cell Phone on Developing Liver of Chick Embryo - A Comparative Study. *J Clin Diagn Res.* 2017 Jul;11(7):AC05-AC09. doi: 10.7860/JCDR/2017/26360.10275. Epub 2017 Jul 1.
- Daels 1976** J. Microwave Heating Of The Uterine Wall During Parturition (symposium summary). *J Microw Power* 11(2):166-168.
- Daily 1948** LE et al. *Am. J. Physiol.* 155, 432.
- de Miguel-Bilbao** 2018 S et al. Effective Analysis of Human Exposure Conditions with Body-worn Dosimeters in the 2.4 GHz Band. *J Vis Exp.* 2018 May 2;(135). doi: 10.3791/56525.

- Dasdag 2015** S et al. Effects of 2.4 GHz radiofrequency radiation emitted from Wi-Fi equipment on microRNA expression in brain tissue. *International Journal of Radiation Biology*, July 2015; 91(7): 555–561. DOI: 10.3109/09553002.2015.1028599.
- Dasdag 2020** et al. Electromagnetic radiation and Alzheimer's disease. *Biotechnology & Biotechnological Equipment*, VOL. 34, NO. 1, 1087–1094, <https://doi.org/10.1080/13102818.2020.1820378>.
- De Luca 2014** et al. Metabolic and Genetic Screening of Electromagnetic Hypersensitive Subjects as a Feasible Tool for Diagnostics and Intervention. *Mediators of Inflammation*. Volume 2014, Article ID 924184, 14 pages. <http://dx.doi.org/10.1155/2014/924184>.
- Deniz 2017** et al. Effects of short and long term electromagnetic fields exposure on the human hippocampus. *Journal of Microscopy and Ultrastructure*. Volume 5, Issue 4, December 2017, Pages 191-197.
- Deniz 2017a** et al. Effects of folic acid on rat kidney exposed to 900 MHz electromagnetic radiation. *Journal of Microscopy and Ultrastructure*. Volume 5, Issue 4, December 2017, Pages 198-205.
- de Pomerai 2000** et al. Non-thermal heat-shock response to microwaves. *Nature* 405(May 25).
- De Salles 2006** et al. Electromagnetic Absorption in the Head of Adults and Children due to Mobile Phone Operation Close to the Head. *Electromagnetic Biology and Medicine*, 25: 349–360, 2006. DOI: 10.1080/15368370601054894.
- de Siqueira 2016** EC et al. Does cell phone use increase the chances of parotid gland tumor development? A systematic review and meta-analysis. *J Oral Pathol Med*. 2016 Dec 9. doi: 10.1111/jop.12531.
- de Vocht 2016** F. Inferring the 1985–2014 impact of mobile phone use on selected brain cancer subtypes using Bayesian structural time series and synthetic controls. *Environment International*. 97:100-107. December 2016.
- Diem 2005** E et al. Non-thermal DNA breakage by mobile-phone radiation (1800MHz) in human fibroblasts and in transformed GFSH-R17 rat granulosa cells in vitro. *Mutat Res*. 583:178-183.
- Dode 2011** et al. Mortality by neoplasia and cellular telephone base stations in the Belo Horizonte municipality, Minas Gerais state, Brazil. *Science of the Total Environment* 409 (2011) 3649–3665. doi:10.1016/j.scitotenv.2011.05.051.
- Dumansky 1986**. Questions Of Hygienic Reglamentation For EM Energy Produced By TV-Broadcasting Objects (meeting abstract). *BioElectromagnetics Society*, 8th Annual Meeting, 1-5 June 1986, Madison, WI, p. 87.
- Dumansky 1982** et al. Weather Radars As A Source Of Superhigh-Frequency EM Fields And The Problems Of Environmental Hygiene. *Russian. Gig Sanit* (2):7-11.
- Dutta 1982** et al. 45Ca²⁺ Efflux From Human And Mouse Neuroblastoma Cells In Culture Following 915 MHz CW AM Microwave Radiation (meeting abstract). *BioElectromagnetics Society*, 4th Annual Meeting, June 28 - July 2, 1982, Los Angeles, CA, p. 29.
- Dutta 1989** et al. Radiofrequency radiation-induced calcium ion efflux enhancement from human and other neuroblastoma cells in culture. *Bioelectromagnetics* 10:197-202.
- Eeftens 2020** M et al. A real-world quality assessment study in six ExpoM-RF measurement devices. *Environmental Research* 182 (2020) 109049.
- El-Maleky 2018** NF et al. Effects of exposure to electromagnetic field from mobile phone on serum hepcidin and iron status in male albino rats. *Electromagn Biol Med*. 2018 Nov 2:1-8. doi: 10.1080/15368378.2018.1531423.
- EPA, 1978**. Efforts By The Environmental Protection Agency To Protect The Public From Environmental Nonionizing Radiation Exposures. NTIS Document No. PB-279 483; 15 pp.
- Ertilav 2018** K et al. Long term exposure to cell phone frequencies (900 and 1800 MHz) induces apoptosis, mitochondrial oxidative stress and TRPV1 channel activation in the hippocampus and dorsal root ganglion of rats. *Metab Brain Dis*. 2018 Jan 13. doi: 10.1007/s11011-017-0180-4.
- Eskander 2012** EF et al. How does long term exposure to base stations and mobile phones affect human hormone profiles? *Clinical Biochemistry* 45 (2012) 157–161.
- Esmekaya 2010** MA et al. Pulse modulated 900 MHz radiation induces hypothyroidism and apoptosis in thyroid cells: A light, electron microscopy and immunohistochemical study. *Int. J. Radiat. Biol.*, Vol. 86, No. 12, December 2010, pp. 1106–1116.
- Esmekaya 2016** MA et al. Mitochondrial hyperpolarization and cytochrome-c release in microwave-exposed MCF-7 cells. *Gen Physiol Biophys*. 2017 Apr;36(2):211-218. doi: 10.4149/gpb_2016021. Epub 2016 Sep 12.
- Everett 1983** SJ et al. Southwest PAVE PAWS Radar System. *Environmental Assessment* (final rept. nov 81-mar 83). NTIS Document No. AD-A128 554/3, 370 pp. Report No. SAM-TR-83-13.
- Everett 1983a** SJ et al. Southeast PAVE PAWS Radar System. *Environmental Assessment* (final rept. nov 81-mar 83). NTIS Document No. AD-A129 370/3, 360 pp. Report No. SAM-TR-83-7.
- Falcioni 2018** L et al. Report of final results regarding brain and heart tumors in Sprague-Dawley rats exposed from prenatal life until natural death to mobile phone radiofrequency field representative of a 1.8 GHz GSM base station environmental emission. *Environ Res*. 2018 Aug;165:496-503. doi: 10.1016/j.envres.2018.01.037.
- Fatehi 2018** D et al. Biological effects of cell-phone radiofrequency waves exposure on fertilization in mice; an in vivo and in vitro study. *Middle East Fertility Society Journal*, 23(2):148-153. June 2018.
- Foerster 2018** M et al. A prospective cohort study of adolescents' memory performance and individual brain dose of microwave radiation from wireless communication. *Environmental Health Perspectives*. <https://ehp.niehs.nih.gov/ehp2747>.
- Foster 1986** MR et al. Dosimetric Study of Microwave Cataractogenesis. *BioElectromagnetics* 7(2):129-140.
- Fox 1978** JW et al. OR RF—The Second Factor. *Am J Assoc Nurse Anesth* 46(5):501-506
- Fragopoulou 2018** AF et al. Hippocampal lipidome and transcriptome profile alterations triggered by acute exposure of mice to GSM 1800 MHz mobile phone radiation: An exploratory study. *Brain Behav*. 2018 May 22.
- Frey 1975** AH et al. Neural Function And Behavior: Defining The Relationship. *Annals of the New York Academy of Sciences* 247:433-438.
- Frohlich 1968** H. Long-Range Coherence and Energy Storage in Biological Systems. *International Journal of Quantum Chemistry*, Vol. 11, 641-649.
- Gandhi 1986** OP. The ANSI Radio frequency Safety Guideline: its Rationale and Some Problems. In "Biological Effects of Electropollution", p. 9-19, Information Ventures.
- Gandhi 1992** OP et al. A frequency-dependent finite-difference time-domain formulation for induced current calculations in human beings, *BioElectromagnetics* 13(6):543-555.
- Gandhi 2005** GA. Genetic damage in mobile phone users: some preliminary findings. *Ind J Hum Genet* 11(2): 99-104, 2005.
- Gandhi 2011** OP. Exposure Limits: The underestimation of absorbed cell phone radiation, especially in children. *Electromagnetic Biology and Medicine*, Early Online: 1–18, 2011. DOI: 10.3109/15368378.2011.622827.
- Gao 2016** et al. [Cellphone electromagnetic radiation damages the testicular ultrastructure of male rats]. [Article in Chinese]. *Zhonghua Nan Ke Xue*. 2016 Jun;22(6):491-495.

- Garaj-Vrhovac 1990** V et al. The effect of microwave radiation on the cell genome. *Mutat Res* 243(2):87-93.
- Garaj-Vrhovac 1991** V et al. The Relationship Between Colony-Forming Ability, Chromosome Aberrations and Incidence of Micronuclei in V79 Chinese Hamster Cells Exposed to Microwave Radiation. *Mutat Res* 263(3):143-149.
- Genius 2012** SJ et al. Electromagnetic hypersensitivity: fact or fiction? *SciTotal Environ*. 2012 Jan;414:103-12.
- Gevrek 2017** F. Histopathological, immunohistochemical, and stereological analysis of the effect of *Gingko biloba* (Egb761) on the hippocampus of rats exposed to long-term cellphone radiation. *Histol Histopathol*. 2017 Nov 9;11943.
- Gibson 2016** PR. The Hidden Marginalization of Persons with Environmental Sensitivities. *Ecopyschology*, 8:2, 2016, <http://online.liebertpub.com/doi/pdfplus/10.1089/eco.2016.0003>.
- Grell 2016** K et al. The Intracranial Distribution of Gliomas in Relation to Exposure From Mobile Phones: Analyses From the INTERPHONE Study. *Am J Epidemiol* 2016 0: p. kww082v1-11.
- Gökçek-Saraç 2017** et al. Effects of acute and chronic exposure to both 900 MHz and 2100 MHz electromagnetic radiation on glutamate receptor signaling pathway. *Int J Radiat Biol*. 2017 Jun 1:1-29. doi: 10.1080/09553002.2017.1337279. [Epub ahead of print].
- Gulati 2018** et al. Phenotypic and genotypic characterization of antioxidant enzyme system in human population exposed to radiation from mobile towers. *Mol Cell Biochem* (2018) 440:1–9 <https://doi.org/10.1007/s11010-017-3150-6>.
- Guo 2018** et al. Effects of 1.8 GHz radiofrequency field on microstructure and bone metabolism of femur in mice. *Bioelectromagnetics*. 2018 Jul;39(5):386-393. doi: 10.1002/bem.22125. Epub 2018 Apr 30.
- Gupta 2018** et al. Electromagnetic radiation 2450 MHz exposure causes cognition deficit with mitochondrial dysfunction and activation of intrinsic pathway of apoptosis in rats. *J Biosci*. 2018 Jun;43(2):263-276.
- Gupta 2019** et al. Long-term exposure of 2450 MHz electromagnetic radiation induces stress and anxiety like behavior in rats. *Neurochemistry International* 128 (2019) 1–13. <https://doi.org/10.1016/j.neuint.2019.04.001>.
- Guy 1976** AW et al. Determination of Power Absorption in Man exposed to high frequency EM fields by thermographic measurements on scale models. *IEEE Trans Biomed Eng* 23(5):361-371.
- Gye 2012** et al. Effect of electromagnetic field exposure on the reproductive system. *Clin Exp Reprod Med* 2012;39(1):1-9. <http://dx.doi.org/10.5653/cerm.2012.39.1.1> pISSN 2233-8233 · eISSN 2233-8241.
- Haas 2018**. LiFi is a paradigm-shifting 5G technology. *Reviews in Physics* 3 (2018) 26–31. <https://doi.org/10.1016/j.revip.2017.10.001>.
- Hagras 2016** AM et al. Mobile phones Electromagnetic radiation and NAD+--dependent Isocitrate Dehydrogenase as a mitochondrial marker in Asthenozoospermia. *Biochimie* <http://www.sciencedirect.com/science/article/pii/S2214008516300074>.
- Hallberg 2016** Ö. Cancer incidence vs. FM radio transmitter density. *Electromagnetic Biology and Medicine*. Published online Jun 29, 2016. DOI:10.3109/15368378.2016.1138122.
- Hamada 2011** A et al. Cell Phones and their Impact on Male Fertility: Fact or Fiction. *The Open Reproductive Science Journal*, 2011, 5, 125-137.
- Hamburger 1983** S et al. Occupational Exposure to Nonionizing Radiation and an Association with Heart Disease: An Exploratory Study. *J Chronic Dis* 36(11):791-802.
- Hardell 2002** L et al. Cellular and cordless telephones and the risk for brain tumours. *European Journal of Cancer Prevention*. 11(4):377-386, August.
- Hardell 2007** L et al. Long-term use of cellular phones and brain tumours: increased risk associated with use for more than 10 years. *Occupational and Environmental Medicine* 2007; 64:626-632.
- Hardell 2013** et al. Use of mobile phones and cordless phones is associated with increased risk for glioma and acoustic neuroma. *Pathophysiology*, Volume 20, Issue 2, April 2013, Pages 85-110.
- Hardell 2020** et al. Health risks from radiofrequency radiation, including 5G, should be assessed by experts with no conflicts of interest. *ONCOLOGY LETTERS* 20: 15, 2020.
- Health and Welfare Canada 1991**. Limits of Exposure to Radiofrequency Fields at Frequencies from 10 kHz to 300 GHz. Security Code 6, DHM-RT-160.
- Héroux 1993**. Studies on the pathophysiology of electrical burns and the assessment of tissue viability by means of electrical impedance. *Canadian Electrical Association Report* 165 D 286A.
- Heurtault 1990** J et al. *Acta Zool. Fennica* 190:165-171.
- Heuser 2017** G et al. Functional brain MRI in patients complaining of electrohypersensitivity after long term exposure to electromagnetic fields. *Rev Environ Health* 2017; 32(3): 291–299.
- Hinrikus 2018** H et al. Understanding physical mechanism of low-level microwave radiation effect. *Int J Radiat Biol*. 2018 Oct;94(10):877-882. doi: 10.1080/09553002.2018.1478158.
- Hinton 1960** HE. *Nature* 188:336-337.
- Hirose 2005** M et al. EM Interference of Implantable Unipolar Cardiac Pacemakers by an Induction Oven". *Pacing and Clinical Electrophysiology*, Vol 28, Num 6, June 2005, pp. 540-548(9).
- Houston 2016** BJ et al. The effects of radiofrequency electromagnetic radiation on sperm function. *Reproduction*. 2016 Dec;152(6):R263-R276. Epub 2016 Sep 6.
- Houston 2018** BJ et al. Probing the origins of 1,800 MHz radio frequency electromagnetic radiation induced damage in mouse immortalized germ cells and spermatozoa in vitro. *Front. Public Health*. 2018 Sep 21. <https://doi.org/10.3389/fpubh.2018.00270>.
- Houston 2019** et al. Whole-body exposures to radiofrequency-electromagnetic energy can cause DNA damage in mouse spermatozoa via an oxidative mechanism. *Scientific Reports*, 9:17478, <https://doi.org/10.1038/s41598-019-53983-9>.
- Howse 1993** D. *Radar at sea: the Royal Navy in World War 2*. Macmillan, UK.
- IARC 2013**. <https://publications.iarc.fr/Book-And-Report-Series/Iarc-Monographs-On-The-Identification-Of-Carcinogenic-Hazards-To-Humans/Non-ionizing-Radiation-Part-2-Radiofrequency-Electromagnetic-Fields-2013>.
- IEEE-C95.1-2005**. IEEE Standard for Safety Levels with Respect to Human Exposure to Radio Frequency EM Fields, 3 kHz to 300 GHz, IEEE Standards Coordinating Committee 28, Institute of Electrical and Electronic Engineers, New York, 2005.
- IEEE-C95.3-2002**. IEEE Recommended Practice for the Measurement and Computation Radio Frequency EM Fields with Respect to Human Exposure to such fields, 100 kHz-300 GHz, IEEE Standards Coordinating Committee 28, Institute of Electrical and Electronic Engineers, New York, 2002.
- Italy 2001** Daily, Milan, March 19th.
- Jaffar 2019** et al. Adverse Effects of Wi-Fi Radiation on Male Reproductive System: A Systematic Review. *Tohoku J. Exp. Med.*, 2019, 248, 169-179. doi: 10.1620/tjem.248.169.
- Joyner 1986** et al. Exposure Survey Of Operators Of Radiofrequency Dielectric Heaters In Australia. *Health Phys* 50(3):333-344.
- Kacprzyk 2020** et al. Which sources of electromagnetic field are of the highest concern for

- electrosensitive individuals? – Questionnaire study with a literature review. *Electromagnetic Biology and Medicine*. <https://doi.org/10.1080/15368378.2020.1839489>.
- Kalanjati 2019** et al. Aluminium foil dampened the adverse effect of 2100 MHz mobile phone-induced radiation on the blood parameters and myocardium in rats. *Environmental Science and Pollution Research* (2019) 26:11686–11689. <https://doi.org/10.1007/s11356-019-04601-8>.
- Kamali 2017** et al. Effects of electromagnetic waves emitted from 3G+wi-fi modems on human semen analysis. *Urologia*. 2017 Sep 14:0. doi: 10.5301/uj.5000269.
- Kamali 2018** et al. Evidence of oxidative stress after continuous exposure to Wi-Fi radiation in rat model. *Environ Sci Pollut Res Int*. 2018 Oct 21. doi: 10.1007/s11356-018-3482-0.
- Karimi 2018** et al. 2.45 GHz microwave radiation impairs learning, memory, and hippocampal synaptic plasticity in the rat. *Toxicol Ind Health*. 2018 Oct 21:748233718798976. doi: 10.1177/0748233718798976.
- Kathuria 2017** et al. Mobile phone use and risk of brain tumours: a systematic review of association between study quality, source of funding, and research outcomes. *Neurological Sciences*. 2017 Feb 17. doi: 10.1007/s10072-017-2850-8.
- Kerimoglu 2018** et al. A histopathological and biochemical evaluation of oxidative injury in the sciatic nerves of male rats exposed to a continuous 900-megahertz electromagnetic field throughout all periods of adolescence. *J Chem Neuroanat*. 2018 Jan 10. pii: S0891-0618(17)30212-0. doi: 10.1016/j.jchemneu.2018.01.001.
- Kesari 2018** et al. Radiations and male fertility. *Reprod Biol Endocrinol*. 2018 Dec 9;16(1):118. doi: 10.1186/s12958-018-0431-1.
- Khurana 2010** et al. Epidemiological Evidence for a Health Risk from Mobile Phone Base Stations. *INT J OCCUP ENVIRON HEALTH* 2010;16:263–267.
- Kiselev 1988** VF et al. Influence of weak magnetic fields and UHF radiation on certain dielectric and optical properties of water and aqueous solutions. Translated from *Teoreticheskaya i Eksperimental'naya Khimiya* 1988;24(3):330-334.
- Knowland 2014** et al., Stepwise Recruitment of Transcellular and Paracellular Pathways Underlies Blood-Brain Barrier Breakdown in Stroke. *Neuron* (2014), <http://dx.doi.org/10.1016/j.neuron.2014.03.003>.
- Kolb 2003a** C et al. Do airport metal detectors interfere with implantable pacemakers or cardioverter-defibrillators? *J Am Coll Cardiol* 41:2054-2059.
- Kolb 2003b** C et al. Are airport metal detectors hazardous for patients with implantable cardioverter defibrillators? *PACE*.26(Pt II):1079. Abstract 602.
- Kondra 1970** et al. Growth and Reproduction of Chickens Subjected to Microwave Radiation. *Can. J. Anim. Sci.*50: 639-644 (Dec. 1970).
- Koppel 2019**. Safety Management of Electromagnetic Fields in the Work Environment. Tallinn University of Technology Doctoral Thesis. 11/2019.
- Koppel 2019a** et al. Radiofrequency radiation from nearby mobile phone base stations-a case comparison of one low and one high exposure apartment. *Oncology Letters* 18: 5383-5391, 2019. DOI: 10.3892/ol.2019.10899.
- Kostoff 2017** et al. Modified health effects of non-ionizing electromagnetic radiation combined with other agents reported in the biomedical literature. In C.D. Geddes (ed.), *Microwave Effects on DNA and Proteins*. Switzerland: Springer, pp. 97-158. DOI 10.1007/978-3-319-50289-2.
- Kues 1992** et al. Increased sensitivity of the non-human primate eye to microwave radiation following ophthalmic drug prepretreatment. *BioElectromagnetics* 13(5): 379-393.
- Kulaber 2017** et al. Alterations of thymic morphology and antioxidant biomarkers in 60-day-old male rats following exposure to a continuous 900 MHz electromagnetic field during adolescence. *Biotech Histochem*. 2017 Jun 9:1-7. doi: 10.1080/10520295.2017.1312525.
- Kumar 2021** et al. Effect of mobile phone signal radiation on epigenetic modulation in the hippocampus of Wistar rat. *Environmental Research* 192 (2021) 110297. <https://doi.org/10.1016/j.envres.2020.110297>.
- Kuster 1992** et al. Energy Absorption mechanisms by biological bodies in the near field of dipole antennas above 300 MHz. *IEEE Transactions on Vehicular Technology* 41(1):17-23.
- Kuster 1993**. Multiple multipole method for simulating em problems involving biological bodies. *IEEE Trans Biomed Eng* 40(7):611-620.
- Kuster 1993a** et al. Proceedings of VDE Meeting, Bad Nauheim, Germany, 93/11/9-10.
- Kwee 1997** et al. Radiofrequency electromagnetic fields and cell proliferation. Presented at the Second World Congress for Electricity and Magnetism in Biology and Medicine, June 8-13, 1997 in Bologna, Italy.
- Lai 1987** H et al. A Review of Microwave Irradiation and Actions of Psychoactive-Drugs. *IEEE Eng Med Biol* 6(1):31-36.
- Lai 1995** H et al. Acute low-intensity MW exposure increases DNA single-strand breaks in rat brain cells. *BioElectromagnetics* 16:207-210.
- Lai 1996** H et al. Single- and double-strand DNA breaks in rat brain cells after acute exposure to radiofrequency electromagnetic radiation. *Int J Radiat Biol* 69(4):513-521.
- Lai 1997a** H et al. Melatonin and a spin-trap compound block radiofrequency electromagnetic radiation-induced DNA strand breaks in rat brain cells. *Bioelectromagnetics* 18(6):446-454.
- Lai 1997b** H et al. Melatonin and N-tert-butyl-alpha-phenylnitron block 60-Hz magnetic field-induced DNA single and double strand breaks in rat brain cells. *J Pineal Res*. 22(3):152-162.
- Lai 2005** H et al. Interaction of microwaves and a temporally incoherent magnetic field on single and double DNA strand breaks in rat brain cells. *Electromag Biol Med* 24:23-29.
- Laliberté 1992** L. Machines industrielles chauffant par perte diélectrique ou par effect d'induction. IRSST report, Montréal, Canada.
- Lancranjan 1975** I et al. Gonadic Function in Workmen with Long-Term Exposure to Microwaves. *Health Phys* 29:381-383.
- Larsen 1991** AI et al. Gender-Specific Reproductive Outcome and Exposure to High-Frequency EM Radiation Among Physiotherapists. *Scand J Work Environ Health* 17(5):324-329.
- Lasalvia 2018** M et al. Exposure to 1.8 GHz electromagnetic fields affects morphology, DNA-related Raman spectra and mitochondrial functions in human lympho-monocytes. *PLoS One*. 2018 Feb 20;13(2):e0192894. doi: 10.1371/journal.pone.0192894. eCollection 2018.
- Lau 1984** RWM et al. Some Observations On Stray Magnetic Fields And Power Outputs From Short-Wave Diathermy Equipment. *Health Phys* 84(4):939-943.
- Leask 1977** MJM. *Nature* 267:144-145.
- Lena 2017** K et al. Measurements of Radiofrequency Radiation with a Body-Borne Exposimeter in Swedish Schools with Wi-Fi. *Front. Public Health*, 20 November 2017 | <https://doi.org/10.3389/fpubh.2017.00279>.
- Lester 1982** JR et al. Cancer Incidence And EM Radiation. *J Bioelectr* 1(1):59-76.
- Lester 1982a** JR et al. Cancer Mortality And Air-Force-Bases. *J Bioelectr* 1(1):77-82.
- Levine 2017** et al. Temporal trends in sperm count: a systematic review and meta-regression analysis. *Human Reproduction Update*, Vol.23, No.6 pp. 646–659, 2017. doi:10.1093/humupd/dmx022.
- Lin 1986** RS et al. Brain Tumors In Electrical Workers. *Biological Effects of Electropollution: Brain Tumors and Experimental Models*. Dutta, S. K. and Millis, R. M., eds., Philadelphia: Information Ventures, Inc., p. 21-32.

- Liu 1991** YH et al. Biopsies of Human Testes Receiving Multiple Microwave Irradiation: an Histological and Ultramicroscopical Study. *J Bioelectr* 10(1&2):213-230.
- Liu 2014** et al. Association between mobile phone use and semen quality: a systemic review and meta-analysis. *Andrology*. 2014 Jul;2(4):491-501.
- Lixia 2006** S et al. Effects of 1.8GHz radiofrequency field on DNA damage and expression of heat shock protein 70 in human lens epithelial cells. *Mutat Res*. 602:135-142.
- Login 1994** GR et al. *The microwave toolbox. A practical guide for microscopists*. Boston: Beth Israel Hospital.
- Lonn 2004** S et al. Mobile Phone Use and the Risk of Acoustic Neuroma. *Epidemiology*. 15(6):653-659, November.
- Lopez-Martin 2006** E et al. GSM radiation triggers seizures and increases cerebral c-Fos positivity in rats pretreated with subconvulsive doses of picrotoxin. *Neurosci Lett*. 398:139-144.
- López-Furelos 2018** A et al. Exposure to radiation from single or combined radio frequencies provokes macrophage dysfunction in the RAW 264.7 cell line. *Int J Radiat Biol*. 2018 Apr 30:1-12. doi: 10.1080/09553002.2018.1465610.
- Lu 1992** ST et al. Abnormal Cardiovascular Responses Induced By Localized High Power Microwave Exposure. *IEEE Trans Biomed Eng* 39(5):484-492.
- Lu 2017** X et al. Association of excessive mobile phone use during pregnancy with birth weight: an adjunct study in Kumamoto of Japan. *Environment and Children's Study*. *Environ Health Prev Med*. 2017 Jun 8;22(1):52. doi:10.1186/s12199-017-0656-1.
- Lukashevsky 1990** KV et al. Switching of prophage lambda genes in *Escherichia coli* by millimeter waves. *Medical Science Research* 18:955-957.
- Mahmoudi 2018** G et al. Effects of mobile phone prolonged radiation on kidney cells; an in-vitro study. *J Renal Injury Prevention*. 7(3):175-179.DOI: 10.15171/jrip.2018.42.
- Marcickiewicz 1986** J et al. Microwave radiation enhances teratogenic effect of cytosine arabinoside in mice. *Biol. Neonate* 50:75-82.
- Marjanovic 2017** CAM et al. In vitro non-thermal oxidative stress response after 1800 MHz radiofrequency radiation. *General Physiology and Biophysics*. 36(4):407-414. Oct 2017.
- Marjanovic 2017a** CAM et al. Oxidative stress response in SH-SY5Y cells exposed to short-term 1800 MHz radiofrequency radiation. *J Environ Sci Health A Tox Hazard Subst Environ Eng*. 2017 Nov 17:1-7. doi: 10.1080/10934529.2017.1383124.
- Markov 2010** AE et al. Microwaves from Mobile Phones Inhibit 53BP1 Focus Formation in Human Stem Cells More Strongly Than in Differentiated Cells: Possible Mechanistic Link to Cancer Risk. *Environ Health Perspect* 118:-doi:10.1289/ehp.0900781.
- Markov 2013** et al. Wi-Fi technology – an uncontrolled global experiment on the health of mankind. *Electromagnetic Biology and Medicine*, June 2013; 32(2): 200–208.
- Markova 2005** E et al. Microwaves from GSM Mobile Telephones Affect 53BP1 and gamma-H2AX Foci in Human Lymphocytes from Hypersensitive and Healthy Persons. *Environ Health Perspect*. 113(9):1172-1177.
- Markova 2010** E et al. Microwaves from Mobile Phones Inhibit 53BP1 Focus Formation in Human Stem Cells More Strongly Than in Differentiated Cells: Possible Mechanistic Link to Cancer Risk. *Environ Health Perspect*, 118(3):394-399, March 2010. doi:10.1289/ehp.0900781.
- Marshall 2017** et al. Electromog and autoimmune disease. *Immunology Research*. Feb;65(1):129-135. doi: 10.1007/s12026-016-8825-7.
- Masoumi 2018** A et al. Radiofrequency radiation emitted from Wi-Fi (2.4 GHz) causes impaired insulin secretion and increased oxidative stress in rat pancreatic islets. *Int J Radiat Biol*. 2018 Jun 18:1-20. doi: 10.1080/09553002.2018.1490039.
- Massardier-Pilonchery 2019** et al. Assessment of Personal Occupational Exposure to Radiofrequency Electromagnetic Fields in Libraries and Media Libraries, Using Calibrated On-Body Exposimeters. *Int. J. Environ. Res. Public Health* 2019, 16, 2087; doi:10.3390/ijerph16122087.
- Mausset 2001** A et al. Effects of radiofrequency exposure on the GABAergic system in the rat cerebellum: clues from semi-quantitative immunohistochemistry. *Brain Res* 912(1):33-46.
- Mausset-Bonnefont 2004** AL et al. Acute exposure to GSM 900-MHz electromagnetic fields induces glial reactivity and biochemical modifications in the rat brain. *Neurobiol Dis*. 17(3):445-454.
- McCarty 2011** DE et al. Electromagnetic hypersensitivity: evidence for a novel neurological syndrome. *Int J Neurosci*. 2011 Dec;121(12):670-6. doi: 10.3109/00207454.2011.608139. Epub 2011 Sep 5.
- McIvor 1998** ME et al. Study of pacemaker and implantable cardioverter defibrillator triggering by electronic article surveillance devices (SPICED TEAS). *Pacing and Clinical Electrophysiology* 21(October):1847.
- MWN 2020**. <https://microwavenews.com/news-center/de-kun-li-crc>
- Michelozzi 2002** et al. Adult and Childhood Leukemia near a High-Power Radio Station in Rome, Italy. *American Journal of Epidemiology*, Vol. 155, No. 12.
- Mikolaichik 1987**. Response of the Endocrine System to EM Fields (meeting abstract). *Mechanisms of Biological Action of EM Fields*. 27-31 October 1987, Pushchino, USSR, USSR Acad. of Sciences, Res.Center for Biological Studies, Inst. of Biological Physics, Coordination Council of Comecon Countries and Yugoslavia for Res. in the Fields of Biological Physics: 33-34.
- Milham 1985** S Jr. Silent Keys: Leukaemia Mortality In Amateur Radio Operators (letter). *Lancet* 2(8432):812.
- Milham 1988** S Jr. Increased Mortality In Amateur Radio Operators Due To Lymphatic and Hematopoietic Malignancies. *Am J Epidemiol* 127(1):50-54.
- Miller 2018** et al. Cancer epidemiology update, following the 2011 IARC evaluation of radiofrequency electromagnetic fields (Monograph 102). *Environmental Research* 167 (2018) 673–683.
- Miller 2019** et al. Risks to Health and Well-Being from Radio-Frequency Radiation Emitted by Cell Phones and Other Wireless Devices. *Front. Public Health* 7:223. doi: 10.3389/fpubh.2019.00223.
- Moon 2020**. Health effects of electromagnetic fields on children. *CEP* Vol. 63, No. 11, 422–428, 2020. <https://doi.org/10.3345/cep.2019.01494>.
- Morgan 2016** et al. Are Third Generation Cellphones with Lower Radiated Power More Carcinogenic Than Second Generation Cellphones?—An Exploration of Recent Data. Poster at BIOEM 2016 Conference.
- Morley 2018** et al. Digitalisation, energy and data demand: The impact of Internet traffic on overall and peak electricity consumption. *Energy Research & Social Science*. Volume 38, April 2018, Pages 128-137. <https://doi.org/10.1016/j.erss.2018.01.018>.
- Mokarram 2017** et al. Effect of Exposure to 900 MHz GSM Mobile Phone Radiofrequency Radiation on Estrogen Receptor Methylation Status in Colon Cells of Male Sprague Dawley Rats. *J Biomed Phys Eng*. 2017 Mar 1;7(1):79-86. eCollection 2017.
- Mortavazi 2009** et al. Alterations in TSH and Thyroid Hormones following Mobile Phone Use. *Oman Medical Journal* 2009, Volume 24, Issue 4, 274-8, October 2009.
- Mortazavi 2010** et al. Effects of Laptop Computers' Electromagnetic Field on Sperm Quality. *J Reprod Infertil*. 2010;11(4):344.
- Mortazavi 2017** et al. Adaptive Response Induced by Pre-Exposure to 915 MHz Radiofrequency: A Possible Role for Antioxidant Enzyme Activity. *J Biomed Phys Eng*. 2017 Jun 1;7(2):137-142.

- Movahedi 2019** et al. Antibacterial Susceptibility Pattern of the *Pseudomonas aeruginosa* and *Staphylococcus aureus* after Exposure to Electromagnetic Waves Emitted from Mobile Phone Simulator. *J Biomed Phys Eng.* 2019;9(6):637-646. <https://doi.org/10.31661/jbpe.v0i0.1107>.
- Mugunthan 2016** N et al. Effects of Long Term Exposure of 900-1800 MHz Radiation Emitted from 2G Mobile Phone on Mice Hippocampus- A Histomorphometric Study. *J Clin Diagn Res.* 2016 Aug;10(8):AF01-6. doi: 10.7860/JCDR/2016/21630.8368.
- Nakas 1981** M et al. Effect Of Repeated 2450-MHz Microwave Radiations On The Acetylcholinesterase Activity In Developing Rat Brain. *Period Biol* 81(1):173-174.
- Narayanan 2018** SN et al. Modulatory effect of 900 MHz radiation on biochemical and reproductive parameters in rats. *Bratisl Lek Listy.* 2018;119(9):581-587. doi: 10.4149/BLL_2018_105.
- Narayanan 2018a** SN et al. Radiofrequency electromagnetic radiation exposure effects on amygdala morphology, place preference behavior and brain caspase-3 activity in rats. *Environ Toxicol Pharmacol.* 2018 Mar;58:220-229. doi: 10.1016/j.etap.2018.01.009. Epub 2018 Jan 31.
- Narayanan 2019** et al. Radiofrequency electromagnetic radiation-induced behavioral changes and their possible basis. *Environmental Science and Pollution Research* (2019) 26:30693–30710. <https://doi.org/10.1007/s11356-019-06278-5>.
- Narasimhan 1991** et al. Altered restriction patterns of microwave irradiated lambda phage DNA. *Biochem Int* 25(2):363-370.
- National Toxicology Program 2018.** NTP technical report on the toxicology and carcinogenesis studies in Hsd:Sprague Dawley SD rats exposed to whole-body radio frequency radiation at a frequency (900 MHz) and modulations (GSM and CDMA) used by cell phones. NTP TR 595. Research Triangle Park, NC. November, 2018. https://www.niehs.nih.gov/ntp-temp/tr595_508.pdf.
- Nikogosjan 1960.** In: O biologiceskom vozdeistvii sverhvysokih castot, vol. 1. Moskva, p. 43.
- Nikolova 2005** et al. Electromagnetic fields affect transcript levels of apoptosis-related genes in embryonic stem cell-derived neural progenitor cells. *ASEB J.* 19(12):1686-1688.
- Novoselova 2017** et al. Involvement of the p38 MAPK signaling cascade in stress response of RAW 264.7 macrophages. *Dokl Biol Sci.* 2017 Sep;476(1):203-205. doi: 0.1134/S0012496617050015. Epub 2017 Nov 4.
- Oh 2018** et al. Effect of Electromagnetic Waves from Mobile Phones on Spermatogenesis in the Era of 4G-LTE. *BioMed Research International.* Volume 2018, Article ID 1801798, 8 pages. <https://doi.org/10.1155/2018/1801798>.
- Osiander 1995** R et al. Microwave absorption in melanotic eye tissues. 17th Annual meeting of the BioElectromagnetics Society, Boston, June 18-22.
- Othman 2017** H et al. Postnatal development and behavior effects of in-utero exposure of rats to radiofrequency waves emitted from conventional WiFi devices. *Environ Toxicol Pharmacol.* 2017 Apr 22;52:239-247. doi: 10.1016/j.etap.2017.04.016.
- Othman 2017a** H et al. Effects of prenatal exposure to WiFi signal (2.45 GHz) on postnatal development and behavior in rat: Influence of maternal restraint. *Behavioural Brain Research.* 36:291-302. May 2017. <http://dx.doi.org/10.1016/j.bbr.2017.03.011>.
- Ouellet-Hellstrom 1993** R et al. Miscarriages among female physical therapists who report using radio- and microwave-frequency EM radiation. *Am. J. Epidemiol.* 138:775-86.
- Oscar 1977** KJ et al. Microwave Alterations Of The Blood-Brain Barrier System Of Rats. *Brain Research* 126:281-293.
- Özsobaci 2018** NP et al. Selenium supplementation ameliorates electromagnetic field-induced oxidative stress in the HEK293 cells. *Journal of Trace Elements in Medicine and Biology.* Available online 13 April 2018.
- Pandey 2016** N et al. Radiofrequency radiation (900 MHz)-induced DNA damage and cell cycle arrest in testicular germ cells in swiss albino mice. *Toxicol Ind Health.* 2016 Oct 13. pii: 0748233716671206.
- Paulraj 2006** R et al. Single strand DNA breaks in rat brain cells exposed to microwave radiation. *Mutat Res.* 596:76-80.
- Pearce 2020** et al. Limiting liability with positioning to minimize negative health effects of cellular phone towers. *Environmental Research* 181 (2020) 108845. <https://doi.org/10.1016/j.envres.2019.108845>.
- Peipei 2016** Y et al. Overview of domestic and foreign standards for electromagnetic radiation. 7th Asia Pacific International Symposium on Electromagnetic Compatibility. Volume: 01 Pages: 1168 - 1171, DOI: 10.1109/APEMC.2016.7522975.
- Peleg 2018** M et al. Radio frequency radiation-related cancer: assessing causation in the occupational/military setting. *Environ Res.* 2018 Feb 9;163:123-133. doi: 10.1016/j.envres.2018.01.003.
- Perchec 1995** et al. Relationship between sperm ATP content and motility of carp spermatozoa. *Journal of Cell Science* 108, 747-753.
- Persson 1997** et al. BBB permeability in rats exposed to electromagnetic fields used in wireless communication. *Wireless Networks*:455–461.
- Petersen 1992** et al. Radio-Frequency EM Fields Associated With Cellular-Radio Cell-Site Antennas. *BioElectromagnetics* 13(6):527-542.
- Petitdant 2018** et al. Alteration of adaptive behaviors of progeny after maternal mobile phone exposure. *Environmental Science and Pollution Research.* 25(11):10894-10903. Apr 2018.
- Phillips 1992** et al. *Nature* 359:142-144.
- Phillips 1993** et al. Wavelength-dependent effects of light on magnetic compass orientation in *Drosophila melanogaster*. *J Comp. Physiol. A* 172:303-308.
- Phillips 1998**, JL et al. DNA damage in Molt-4 T- lymphoblastoid cells exposed to cellular telephone radiofrequency fields in vitro. *Bioelectrochem. Bioenerg.* 45:103-110.
- Phillips 2018 et al. **Brain Tumours: Rise in Glioblastoma Multiforme Incidence in England 1995–2015 Suggests an Adverse Environmental or Lifestyle Factor. Journal of Environmental and Public Health Volume 2018, Article ID 7910754.** <https://doi.org/10.1155/2018/7910754>
- Philips 2019.** https://www.sciencesetavenir.fr/high-tech/reseaux-et-telecoms/philips-lance-des-ampoules-pour-se-connecter-en-li-fi-l-internet-par-la-lumiere_134792.
- PhoneGate 2019.** <https://www.phonegatealert.org/en/>
- Plets 2015** et al. Exposure assessment of microwave ovens and impact on total exposure in wlns. *Radiation Protection Dosimetry* (2016), Vol. 168, No. 2, pp. 212–222 doi:10.1093/rpd/ncv284.
- Pockett 2019.** Conflicts of Interest and Misleading Statements in Official Reports about the Health Consequences of Radiofrequency Radiation and Some New Measurements of Exposure Levels. *Magnetochemistry* 2019, 5, 31; doi:10.3390/magnetochemistry5020031
- Pokorný 2017** J et al. Warburg effect-damping of electromagnetic oscillations. *Electromagn Biol Med.* 2017 Jun 2:1-9. doi: 10.1080/15368378.2017.1326933.
- Polk 1986** C et al. Handbook of Biological Effects of EM Fields. CRC Press, p.468-479.
- Pong 2018.** <https://www.mpdigest.com/2018/06/25/filters-and-the-problem-of-rf-pollution/>
- Postaci 2018** et al. The physiopathological effects of quercetin on oxidative stress in radiation of 4.5 g mobile phone exposed liver tissue of rat. *Bratisl Lek Listy.* 2018;119(8):481-489. doi: 10.4149/BLL_2018_088.
- Poulliet de Gannes 2017** et al. Effects of GSM and UMTS mobile telephony signals on neuron degeneration and blood-brain barrier permeation in the rat brain. *Sci Rep.* 2017 Nov 14;7(1):15496. doi: 10.1038/s41598-017-15690-1.

- Ramirez-Vasquez 2020** et al. Georeferencing of Personal Exposure to Radiofrequency Electromagnetic Fields from Wi-Fi in a University Area. *Int. J. Environ. Res. Public Health* 2020, 17, 1898; doi:10.3390/ijerph17061898.
- Ray 1990** S et al. Physiological changes in rats after exposure to low levels of microwaves. *Radiat. Res.* 123:199-202; 1990.
- Rea 1997** WJ et al. Electromagnetic field sensitivity. *Journal of Bioelectricity.* 1991; 10(1 &2): 243-256.
- Repacholi 1997** MH et al. "Lymphomas in Emu-Pim 1 Transgenic Mice Exposed to Pulsed 900 MHz EM Field". *Rad Res* 147:631-640.
- Richardson 1948** AW et al. Experimental Lenticular Opacities Produced By Microwave Irradiations. *Archives of Physical Medicine* 29:765-769.
- Robinette 1980** CD et al. Effects Upon Health Of Occupational Exposure To Microwave Radiation (Radar). *Am J Epidemiol* 112(1):39-53.
- Roth 1994** BJ et al. In vitro evaluation of a 4-leaf coil design for magnetic stimulation of peripheral nerve. *Electroencephalography and Clinical Neurophysiology/Evoked Potentials Section, Volume 93, Issue 1, February 1994, Pages 68-74.*
- Rubenstein 1988** E. Imaging with photons. *Scientific American Medicine, CTM-III, p 10, 11.*
- Sadetzki 2007** S et al. Cellular Phone Use and Risk of Benign and Malignant Parotid Gland Tumors—A Nationwide Case-Control Study, *American Journal of Epidemiology, Dec 6th, 2007.*
- Sagar 2018** S et al. Comparison of radiofrequency electromagnetic field exposure levels indifferent everyday microenvironments in an international context. *Environment International* 114 (2018) 297–306.
- Sage 2018** C et al. Electromagnetic Fields, Pulsed radiofrequency radiation, and epigenetics: How wireless technologies may affect childhood development. *Child Dev.* 2018 Jan;89(1):129-136. doi: 10.1111/cdev.12824. Epub 2017 May 15.
- Sagripanti 1987** JL et al. Microwave Effects On Plasmid DNA. *Radiat Res* 110(2):219-231
- Saikhedkar 2014** N et al. Effects of mobile phone radiation (900 MHz radiofrequency) on structure and functions of rat brain. *Neurological Research, 36:12, 1072-1079, DOI:10.1179/1743132814Y.0000000392.*
- Salford 1994** LG et al. Permeability of the blood-brain barrier induced by 915 MHz electromagnetic radiation, continuous wave and modulated at 8, 16, 50, and 200 Hz. *Microscopy research and technique.* 27:535-542.
- Salford 2003** LG et al. Nerve Cell Damage in Mammalian Brain after Exposure to Microwaves from GSM Mobile Phones. *Environmental Health Perspectives, vol 111, no 7, June 2003.*
- Sangun 2014** O et al. The effects of long-term exposure to a 2450 MHz electromagnetic field on growth and pubertal development in female Wistar rats. *Electromagn Biol Med.* 2015 Mar;34(1):63-71. doi: 10.3109/15368378.2013.871619.
- Sangun 2015** O et al. The effects of EMF on the endocrine System in Children and Adolescents. *Pediatr Endocrinol Rev.* 2015 Dec;13(2):531-45.
- Sancetta 1958** SM et al. The effects of "dry" heat on the circulation of man. I. General hemodynamics. *Am. Heart J.* 56:212.
- Sánchez-Montero 2017** R et al. Long term variations measurement of electromagnetic field exposures in Alcalá de Henares (Spain). *Science of the Total Environment.* 598: 657-668. Nov 2017. <https://doi.org/10.1016/j.scitotenv.2017.03.131>.
- Sangi 2020** et al. Protective Effects of Vitamin E on Mobile Phone induced injury in the Brain of rats. *International Journal of Pharmaceutical and Phytopharmacological Research (eIJPPR), February 2020, Volume 10, Issue 1, Page 97-104.*
- Sanders 1985** AP et al. Effects of Continuous-Wave, Pulsed, and Sinusoidal-Amplitude-Modulated Microwaves on Brain Energy Metabolism. *Bioelectromagnetics* 6:89-97 (1985).
- Santini 2003** et al. Survey Study of People Living in the Vicinity of Cellular Phone Base Stations. *ELECTRON, IAGNETIBCI OLOGY AND MEDICINE* Vol. 22, No. 1, pp. 4149, 2003.
- Santucci 1998** PA et al. Interference with an implantable defibrillator by an electronic antitheft-surveillance device. *New England Journal of Medicine* 339(Nov. 5):1371.
- Sarkar 1994** S et al. Effect of low power microwave on the mouse genome: a direct DNA analysis. *Mutation Research* 320, 141-147.
- Savin 1983** BM et al. New Trends In Standardization Of EM Fields Of Microwave Frequency. *Russian. Gig Tr Prof Zabol* (3):1-4.
- Schaap 2015** K et al. Exposure to MRI-related magnetic fields and vertigo in MRI workers. *Occup Environ Med* 2015;0:1–6. doi:10.1136/oemed-2015-103019.
- Schoeni 2015** A et al. Memory performance, wireless communication and exposure to radiofrequency electromagnetic fields: a prospective cohort study in adolescents. *Environmental International.* Volume 85. Page 343-351.
- Schwan 1986** HP. Biological effects of non-ionizing radiations. *National Council on Radiation and Measurements, Lauriston S. Taylor Lecture no 10 in Radiation Protection, p. 28.*
- Schwertner 1992** HA et al. Effects Of Microwave Fields On Amino Acid Metabolism In Mouse Macrophage Cell Cultures (meeting abstract). *First World Congress for Electricity and Magnetism in Biology and Medicine, 14-19 June, Lake Buena Vista, FL, p. 131.*
- Sepehrimanesh 2016** M et al. Proteomic impacts of electromagnetic fields on the male reproductive system. *Comp Clin Pathol* (2017) 26:309–313. doi:10.1007/s00580-016-2342-x. Published online Oct 13, 2016.
- Sepehrimanesh M** et al. Proteomic analysis of continuous 900-MHz radiofrequency electromagnetic field exposure in testicular tissue: a rat model of human cell phone exposure. *Environ Sci Pollut Res* (2017) 24:13666–13673. DOI 10.1007/s11356-017-8882-z.
- Servantie 1974** B et al. Pharmacologic effects of a pulsed microwave field. In: *Biologic Effects and Health Hazards of Microwave Radiation, Polish Medical Publishers, pp. 37-45.*
- Servantie 1976** B et al. Non Ionizing EM Fields: Environmental Factors In Relation To Military Personnel. *NTIS Document No. AD A035844; 31 pp.*
- Shahin 2017** S et al. Mobile Phone (1800MHz) Radiation Impairs Female Reproduction in Mice, *Mus musculus*, through Stress Induced Inhibition of Ovarian and Uterine Activity. *Reprod Toxicol.* 2017 Aug 2. pii: S0890-6238(17)30167-3. doi: 0.1016/j.reprotox.2017.08.001.
- Shahin 2018** S et al. 1800 MHz mobile phone radiation induced oxidative and nitrosative stress leads to p53 dependent Bax mediated testicular apoptosis in mice. *J Cell Physiol.* 2018 Apr 10. doi: 10.1002/jcp.26558.
- Sharma 2016** A et al. The influence of prenatal 10 GHz microwave radiation exposure on a developing mice brain. *Gen Physiol Biophys.* 2016 Oct 27.
- Sharma 2017** A et al. Ten gigahertz microwave radiation impairs spatial memory, enzymes activity, and histopathology of developing mice brain. *Mol Cell Biochem.* 2017 May 3. doi: 10.1007/s11010-017-3051-8.
- Singh 2020** et al. Effect of radiofrequency radiation on reproductive health. *The Indian Journal of Medical Research Dec. 148 (Suppl 1) S92-S99.*
- Sridhar 1992** et al. Microwave Experiments on Chaotic Billiards. *Microwave Experiments on Chaotic Billiards. Journal of Statistical Physics, Vol. 68, Nos. 1/2, 239-268.*
- Silverman 1980.** Epidemiologic Studies Of Microwave Effects. *Proc IEEE* 88(1):78-84.
- Silverman 1981.** Update On Epidemiology: North American Microwave Studies (meeting abstract). *International Union of Radio Science, 20th General Assembly, 10-19 August, 1981, Washington, DC, p.20.*

- Skotte 1984.** Exposure of Radio Officers to Radio Frequency Radiation on Danish Merchant Ships. *Am Ind Hyg Assoc J* 45(12):791-795.
- Slottje 2016** P et al. Electromagnetic hypersensitivity (EHS) in occupational and primary health care: A nation-wide survey among general practitioners, occupational physicians and hygienists in the Netherlands. *Int J Hyg Environ Health.* 2016 Dec 2. pii: S1438-4639(16)30385-6. doi: 10.1016/j.ijheh.2016.11.013.
- Soldatchenkov 1982.** Hygienic Characteristics Of Environmental Exposure To The EM-Fields Generated By Civil Aviation Radar Stations (meeting abstract). Russian. All-Union Symposium on the Biological Effects of EM Fields, Pushchino, USSR, p. 110-111.
- Stasinopoulou 2016.** Effects of pre- and postnatal exposure to 1880–1900 MHz DECT base radiation on development in the rat. *Reproductive Toxicology*, Volume 65, October 2016, Pages 248–262. <http://dx.doi.org/10.1016/j.reprotox.2016.08.008>.
- Stein 1992** et al. Experimental determination of billiard wave functions. *Phys. Rev. Lett* 68:2867.
- Stewart-DeHaan 1983** et al. In Vitro Studies Of Microwave-Induced Cataract: Separation Of Field And Heating Effects. *Exp Eye Res* 36(1):75-90.
- Stocklin 1981** et al. Low Power Microwave Effects on the Human Electroencephalogram: Supporting Results of Bise. *Physiol Chem Phys* 13(2):175-177.
- Stuchly 1982** et al. Exposure To The Operator And Patient During Short Wave Diathermy Treatments. *Health Phys* 42(3):341-366.
- Subjeck 1978** et al. Non-Thermal Effects Of Microwave Heating On The Cell Periphery As Revealed By The Binding Of Colloidal Iron Hydroxide (meeting abstract). *Radiat Res* 74(3):584.
- Sudan 2018** et al. Maternal cell phone use during pregnancy and child cognition at age 5 years in 3 birth cohorts. *Environ Int.* 2018 Nov;120:155-162. doi: 0.1016/j.envint.2018.07.043.
- Sun 2006** et al. [Effect of acute exposure to microwave from mobile phone on DNA damage and repair of cultured human lens epithelial cells in vitro.] *Zhonghua Lao Dong Wei Sheng Zhi Ye Bing Za Zhi.* 24(8):465-467.
- Swisscom 2003** Reduction of Electromog in Wireless Local Networks. Patent.
- Szmigielski 1996** et al. Cancer morbidity in subjects occupationally exposed to high frequency (radiofrequency and microwave) EM radiation. *Sci Total Environ* 180:9-17.
- Tang 2018** et al. Analysis of the relationship between electromagnetic radiation characteristics and urban functions in highly populated urban areas. *Sci Total Environ.* 2018 Nov 10;654:535-540. doi: 10.1016/j.scitotenv.2018.11.143.
- Tanvir 2016.** Effects of 3G cell phone exposure on the structure and function of the human cytochrome P450 reductase. *Bioelectrochemistry* Volume 111, October 2016, Pages 62–69.
- Testylier 2002** et al. Effects of exposure to low level radiofrequency fields on acetylcholine release in hippocampus of freely moving rats. *Bioelectromagnetics* 23:249-255.
- Thomas 1987** TL et al. Brain Tumor Mortality Risk Among Men with Electrical and Electronics Jobs: A Case-Control Study. *J Natl Cancer Inst* 79(2):233-238.
- Tiazhelova 1982** VG. Three Degrees Of Manifestations Associated With The Nonspecific Changes Occurring In An Organism During Chronic Microwave Irradiation (meeting abstract). All-Union Symposium on the Biological Effects of EM Fields, Pushchino, USSR, p. 130.
- Tohidi 2020** et al. Long-term exposure to electromagnetic radiation from mobile phones can cause considerable changes in the balance of Bax/Bcl2 mRNA expression in the hippocampus of mice. *Electromagnetic Biology and Medicine.* <https://doi.org/10.1080/15368378.2020.1830793>.
- Tofani 1984** S et al. The Assessment Of Unwanted Radiation Around Diathermy RF Capacitive Applicators. *Health Phys* 47(2):235-241.
- Türedi 2017** et al. Biochemical and pathological changes in the male rat kidney and bladder following exposure to continuous 900-MHz electromagnetic field on postnatal days 22-59. *Int J Radiat Biol.* 2017 Jul 27;1-10. doi: 10.1080/09553002.2017.1350768.
- Vagero 1985** et al. Cancer Morbidity Among Workers in the Telecommunications Industry. *Br J Ind Med* 42(3):191-195.
- Varghese 2017** et al. Rats exposed to 2.45 GHz of non-ionizing radiation exhibit behavioral changes with increased brain expression of apoptotic caspase 3. *Pathophysiology.* 2017 Nov 14. pii: S0928-4680(17)30052-4. doi: 10.1016/j.pathophys.2017.11.001.
- Van Zandt 1987.** Microwave Interaction with DNA In Solution (final report). Office of Naval Research. Final Report, May 1985 to September 1987, Contract N00014-84-K-0401.
- Velghe 2019** et al. Characterisation of spatial and temporal variability of RF-EMF exposure levels in urban environments in Flanders, Belgium. *Environmental Research* 175 (2019) 351–366.
- Volkow 2011** et al. Effects of Cell Phone Radiofrequency Signal Exposure on Brain Glucose Metabolism *JAMA.* 2011; 305(8):808-813. doi: 10.1001/jama.2011.186.
- von Niederhausern 2019.** Effects of radiofrequency electromagnetic field exposure on neuronal differentiation and mitochondrial function in SH-SY5Y cells. *Toxicology in Vitro* 61 (2019) 104609. <https://doi.org/10.1016/j.tiv.2019.104609>.
- Vorobyov 2004** et al. Repeated exposure to low-level extremely low frequency-modulated microwaves affects baseline and scopolamine-modified electroencephalograms in freely moving rats. *Int J Radiat Biol.* 80(9):691-698.
- Wall 2019** et al. Real-world cell phone radiofrequency electromagnetic field exposures. *Environmental Research* 171 (2019) 581–592. <https://doi.org/10.1016/j.envres.2018.09.015>.
- Wallace 2019** et al. Effect of mobile phone radiofrequency signal on the alpha rhythm of human waking EEG: A review. *Environmental Research* 175 (2019) 274–286. <https://doi.org/10.1016/j.envres.2019.05.016>.
- Wang 2000** et al. Acute exposure to pulsed 2450-MHz microwaves affects water-maze performance of rats. *BioElectromagnetics* 21:52-56.
- Wang 2005** et al. [Effect of 900 MHz electromagnetic fields on the expression of GABA receptor of cerebral cortical neurons in postnatal rats] *Wei Sheng Yan Jiu.*34(5):546-548.
- Wang 2014** et al. Targeted enhancement of cortical-hippocampal brain networks and associative memory. *Science* 29 August 2014: 345 (6200), 1054-1057. DOI:10.1126/science.1252900.
- Wang 2017** et al. Mobile Phone Use and The Risk of Headache: A Systematic Review and Meta-analysis of Cross sectional Studies. *Scientific Reports*, 7: 12595. DOI:10.1038/s41598-017-12802-9.
- Wang 2018** et al. Wireless Phone Use and Risk of Adult Glioma: Evidence from a Meta-Analysis. *World Neurosurg.* 2018 Jul;115:e629-e636. doi: 10.1016/j.wneu.2018.04.122. Epub 2018 Apr 28.
- Wassermann 1998.** Risk and safety of repetitive transcranial magnetic stimulation: report and suggested guidelines from the International. Workshop on the Safety of Repetitive Transcranial Magnetic Stimulation, June 5–7, 1996. *Electroencephalography and Clinical Neurophysiology/Evoked Potentials Section*, Volume 108, Issue 1, January 1998, Pages 1-16.
- Webb 1974.** *Int. J. Quant. Chem. Quant. Biol. Symp.*, 1:245.
- Webb 1976.** Microwave absorption and its biological effects. *Nutrition Time and Motion in Metabolism and Genetics:* (Springfield: Charles C. Thomas):246-275.
- Webb 1979.** Factors affecting the induction of Lambda prophages by millimetre waves. *Physics Letters* 73A:145-148.

Webb 2016. The 5G Myth: When vision decoupled from reality. de Gruyter. ISBN-13: 978-1547417285.

Wehner 1992 et al. Desert ants on a thermal tightrope. *Nature* 357:586-587.

West 2013 et al. Multifocal Breast Cancer in Young Women with Prolonged Contact between Their Breasts and Their Cellular Phones. *Case Reports in Medicine*, Volume 2013, Article ID 354682, 5 pages, <http://dx.doi.org/10.1155/2013/354682>.

Wueringer 2012 et al. The function of the sawfish's saw. *Current Biology* - 6 March 2012 (Vol. 22, Issue 5, pp. R150-R151).

Xu 2006 et al. Chronic exposure to GSM 1800-MHz microwaves reduces excitatory synaptic activity in cultured hippocampal neurons. *Neurosci Lett.* 398:253-257.

Yahyazadeh 2018 et al. The genomic effects of cell phone exposure on the reproductive system. *Environmental Research*. Volume 167, November 2018, Pages 684-693. doi.org/10.1016/j.envres.2018.05.017.

Yakymenko 2018 et al. Oxidative and mutagenic effects of low intensity GSM 1800 MHz microwave radiation. *Exp Oncol* 2018 40, 4, 282–287.

Yang 2016 et al. Long-Term Evolution Electromagnetic Fields Exposure Modulates the Resting State EEG on Alpha and Beta Bands. *Clin EEG Neurosci.* 2016 Apr 25. pii: 1550059416644887.

Yan 2017. Child and Adolescent Use of Mobile Phones: An Unparalleled Complex Developmental Phenomenon. *Child Dev.* doi:10.1111/cdev.12821.

Yang 2017 et al. Mobile phone use and glioma risk: A systematic review and meta-analysis. *PLoS One.* 2017 May 4;12(5):e0175136. doi: 10.1371/journal.pone.0175136.

Yorgancilar 2017 et al. Does all-day and long-term exposure to radiofrequency radiation emitted from Wi-Fi affect hearing? *Biotechnology & Biotechnological Equipment*, 2017 VOL. 31, NO. 6, 1204–1209. <https://doi.org/10.1080/13102818.2017.1373033>.

Zakharchenko 2016 et al. The effect of cell-phone radiation on rabbits: Lymphocyte enzyme-activity data. *Biophysics.* 61(1):100-104.

Zarei 2019 et al. Mother's Exposure to Electromagnetic Fields before and during Pregnancy is Associated with Risk of Speech Problems in Offspring. *J Biomed Phys Eng* 2019; 9(1).

Zaret 1977 et al. Cataracts And Avionic Radiations. *British Journal of Ophthalmology* 61:383.

Zhang 2002 et al. Study of low-intensity 2450-MHz microwave exposure enhancing the genotoxic effects of mitomycin C using micronucleus test and comet assay in vitro. *Biomed Environ Sci* 15(4):283-290.

Zhang 2006 et al. [Effects of GSM 1800 MHz radiofrequency electromagnetic fields on DNA damage in Chinese hamster lung cells.] *Zhonghua Yu Fang Yi Xue Za Zhi.* 40(3):149-152.

Zhang 2016 et al. Microwaves and Alzheimer's disease (Review). *Experimental and Therapeutic Medicine* 12: 1969-1972, 2016. DOI: 10.3892/etm.2016.3567.

Zhang 2017 et al. Effects of 1.8 GHz Radiofrequency Fields on the Emotional Behavior and Spatial Memory of Adolescent Mice. *Int J Environ Res Public Health.* 2017 Nov 5;14(11). pii: E1344. doi: 10.3390/ijerph14111344.

Zhou 2016 et al. Social behavioral testing and brain magnetic resonance imaging in chicks exposed to mobile phone radiation during development. *BMC Neurosci.* 2016 Jun 10;17(1):36. doi: 10.1186/s12868-016-0266-7.

Zielinski 2020 et al. Effects of pulse-modulated radiofrequency magnetic field (RF-EMF) exposure on apoptosis, autophagy, oxidative stress and electron chain transport function in human neuroblastoma and murine microglial cells. *Toxicology in Vitro* 68 (2020) 104963. <https://doi.org/10.1016/j.tiv.2020.104963>.

Zothansiamia 2017 et al. Impact of radiofrequency radiation on DNA damage and antioxidants in peripheral blood lymphocytes of humans residing in the vicinity of mobile phone base stations. *Electromagn Biol Med.* 2017 Aug 4:1-11. doi: 10.1080/15368378.2017.1350584.

5.9. Answers To Problems

ANSWER 1. Resistors in series are added: $2300 \Omega + 6,000,000 \Omega + 0.0001 \Omega + 16,000 \Omega = 6,018,300.0001 \Omega$. The highest resistance value [$6,000,000 \Omega$] dominates the determination of current flow. Resistors in parallel are added as their inverse values: $1/2300 \Omega + 1/6 \text{ M}\Omega + 1/0.1 \text{ m}\Omega + 1/16 \text{ k}\Omega = 1/R_{\text{total}}$. $4.348 \times 10^{-4} + 1.667 \times 10^{-7} + 10,000 + 6.25 \times 10^{-5} = 1/R_{\text{total}} = 10,000.00049$. $R_{\text{total}} = 0.0001 \Omega$. The lowest resistance value [0.0001Ω] dominates the determination of current flow.

ANSWER 2. $R = V/I = 220 \text{ V} / 6 \text{ A} = 36.7 \Omega$. $I = W/V = 40 \text{ W} / 120 \text{ V} = 0.33 \text{ A}$.

ANSWER 3. Answer: Hectopedes and Kilopedes.

ANSWER 4. Calculate the Ohm value of a $1 \mu\text{F}$ capacitor at 60 Hz. How much current flows through this capacitor if 100 V ac is applied?

ANSWER 5. $f = 1/(2\pi \times 1000 \times 10^{-6}) = 159 \text{ Hz}$.

$$Z = \frac{1}{2\pi f C} = \frac{1}{2 \times 3.1416 \times 60 \text{ Hz} \times 1 \times 10^{-6} \text{ F}} = 2652.6 \Omega$$

$$I = \frac{V}{Z} = \frac{100 \text{ V}}{2652.6 \Omega} = 37.7 \text{ mA}$$

ANSWER 6. If green wire of appliance connected to 120 V, casing is hot, appliance not working.

ANSWER 7. D

ANSWER 8. Oil is a good quencher of electrical arcs because of its thermal capacity and ability to capture electrons.

ANSWER 9. C and D

ANSWER 10. D

ANSWER 11. Because the switch may fail, and there may be more than one switch able to power the circuit.

ANSWER 12. A

ANSWER 13. D

ANSWER 14. Engineer with fibrillation threshold of 150 mA. Be careful, do not use such high thresholds, as minimum fibrillation limits are much lower, especially for children.

ANSWER 15. $I [\text{mA}] = 0.0025 \times 10 [\text{field}] \times 1 [\text{fence height}] \times 40 [\text{fence length}] = 1 \text{ mA}$. Since $1 \text{ mA} > 0.5 \text{ mA}$, cow will feel current.

ANSWER 16. 60 Hz: $Z_{a-b} = 1/\omega C = 1/2\pi \cdot 60 \cdot 10^{-11} = 10^{11}/376.99 = 265,258.2 \text{ k}\Omega$. $I = V/R_{\text{tot}} = V/(Z_{a-b} + Z_{\text{man}}) = 1000 \text{ V}/265,258.4 \text{ k}\Omega = 0.00377 \text{ mA}$. $V = 0.00377 \text{ mA} \times 200 \Omega = 0.754 \text{ mV}$.

100 MHz: $Z_{a-b} = 1/\omega C = 1/2\pi \cdot 100 \cdot 10^6 \cdot 10^{-11} = 159 \Omega$. $I = V/R_{\text{tot}} = V/(Z_{a-b} + Z_{\text{man}})$ $I = 1000 \text{ V}/R_{\text{tot}} = 1000 \text{ V}/359 \Omega = 2.78 \text{ A}$. $V = 2.78 \text{ A} \times 200 \Omega = 557 \text{ V}$.

ANSWER 17. The top plate is at 100 V, the bottom plate at 0 V. Voltage will be uniformly spread across all 10 gaps since capacitance from one plate to the next is the same: inter plate voltage will be 10 V at both frequencies. Increase in frequency directly increases the amount of current passing through the plate array since $I = V/Z = \omega CV$. If 2 plates are bridged, a gap is eliminated and the stack simply behaves as if only 9 gaps existed. Interplate voltage is then $100 \text{ V}/9 = 11.11 \text{ V}$.

ANSWER 18. 547.7 V.

ANSWER 19. ac can be readily be transformed from one voltage level to another with very small losses using transformers. This is not so easy with dc power.

ANSWER 20. In the case of a metallic housing accessible to the workers, the grounding conductor should be sized in such a way that in the event of a fault, the maximum current available from the power circuit can be returned by the grounding conductor while the metallic housing does not rise in potential to a value that can endanger the workers, i.e. approximately 50 V.

ANSWER 21. C.

ANSWER 22. C

ANSWER 23. Acetylene.

ANSWER 24. They are highly explosive.

ANSWER 25. $C = 1/\omega R_c = 1/377 \times 6600 = 0.4 \mu\text{F}$.
 $E = \frac{1}{2} CV^2 \gg \gg V = \sqrt{2E/C} = 10 \text{ V}$.

ANSWER 26. Ignition energy available from the circuit corresponds to the threshold value for the particular gas-air mixture.

ANSWER 27. Exclusion of explosive gases (pressurized) by purging using a non-explosive gas and containment and cooling of exploded gases (explosion-proof housing).

ANSWER 28. $R = (P \log_{10} (4L/d))/2.72L = 6 = (100,000 \log_{10} (400/d))/272$.

$d = 3.85 \text{ m}$.

ANSWER 29. D.

ANSWER 30. C.

ANSWER 31. Battery and wire problem. A is true: The electric field in the wire is 1 V/m, along the wire. The electric potential of the battery must spread evenly along the length of the uniform wire. B mentions an approximation: relative to values across insulators, which can be very high, fields in conductors are low because electron motion tends to conterbalance the applied fields. C: the field cannot be enhanced because the wire is uniform.

ANSWER 32. $(0.2 \times 1000/0.5 - 0.2 \times 20/0.5) = 392 \mu\text{T}$.

ANSWER 33. The charge is the same charge that would cause the capacitor to go from 0 V to 20 V since for a given capacitor [i.e. given C], charge is linearly proportional to voltage. $Q = CV = 10^{-5} \text{ F} \times 20 \text{ V} = 2 \times 10^{-4} \text{ Coulombs}$.

ANSWER 34. Water and benzene in a microwave oven. Water heats fastest because although having half the heat capacity is an advantage, the ratio of dielectric constants between the two substances is much larger than 2.

ANSWER 35. Truck and man under 735 kV line. Calculation of the capacitive division would show that truck and man are at the same voltage: when they touch, no current flows. Truck grounded through the barefoot worker passes current by its capacitance to the line, 12 pF. $I = V/Z = 735,000 \times \omega C = 735,000 \cdot 2 \cdot \pi \cdot f \cdot 12 \cdot 10^{-12} = 3.3 \text{ mA}$. Since $3.3 \text{ mA} > 1 \text{ mA}$, sensation occurs. Heaviest truck "Electric man" can touch: $I_{\text{limit}} = 0.290 \text{ A} = V/Z = 735,000 \cdot 2 \cdot \pi \cdot f \cdot C \gg \gg C = 1,047 \text{ pF} = \text{Tonnage}/0.05 \gg \gg \text{Tonnage} = 52.3 \text{ tons}$.

ANSWER 36. First find the Ω values for capacitances: $1/\omega C = 133 \text{ M}\Omega$ for 20 pF and $1.33 \text{ M}\Omega$ for 2000 pF. Current going

through circuit = $I = V/R_{\text{tot}} = 315,000 \text{ V}/(133 + 1.33)\text{M}\Omega = 2.344 \text{ mA}$. Potential of truck = $V = IR = 2.344 \text{ mA} \times 1.33 \text{ M}\Omega = 3118 \text{ V}$. Crest of this root-mean-square value is $3118 \text{ V} \times \sqrt{2} = 4410.6 \text{ V}$, which represents the highest instantaneous value that can be reached by the truck. $E = \frac{1}{2} CV^2 = \frac{1}{2} \times 2000 \text{ pF} \times (4410.6 \text{ V})^2 = 19.45 \text{ mJ}$. Therefore, there is no danger of explosion.

ANSWER 37. A: $I = V/R = 110/1000 = 110 \text{ mA}$, fibrillation risk. B: $I = 5/1000 = 5 \text{ mA}$, absolutely safe, except for children. C: $R_c = 1/377 \times 10^{-11} = 265 \text{ M}\Omega$, $I = 1 \text{ MV}/265 \text{ M}\Omega = 3.77 \text{ mA}$. Can be felt only. D: $R_c = 1/377 \times 10^4 \times 10^{-12} = 265 \text{ k}\Omega$, $I = 1 \text{ kV}/265 \text{ k}\Omega = 3.77 \text{ mA}$. Cannot be felt at this frequency.

ANSWER 38. Measuring the geomagnetic field with a coil. Impossible, since EM induction needs a CHANGE in the magnetic flux density with time in the coil opening. Fixed position with constant field cannot generate variation in magnetic flux.

ANSWER 39. $H = E/377 = 275 \text{ [V/m]}/377 = 0.73 \text{ A/m} = 0.92 \text{ }\mu\text{T}$. RMS = Crest/ $\sqrt{2} = 275 \text{ [V/m]}/1.4142 = 194 \text{ V/m}$ RMS. $P = E^2/Z = (194 \text{ V/m})^2/377 \text{ }\Omega = 100 \text{ W/m}^2 = 10 \text{ mW/cm}^2$.

ANSWER 40. ELF meter on the end of a perch: so that the hygienist's body does not disturb the field being measured: the body is electrically very conductive.

ANSWER 41. Unperturbed field is the relevant value to consider for safety purposes. All standards and instruments are referred to the electric field value before it is disturbed by the human body.

ANSWER 42. Window effects. Appearance of biological effects at specific amplitudes and frequencies of signals and their disappearance at increased or decreased amplitudes or frequencies.

ANSWER 43. Transducers in dosimeter. Orientation of the electric field with respect to the body is predictable. Since the body is electrically very conductive, the electric field is perpendicular to the body's surface. The magnetic field's orientation is not disturbed by the body and so depends on the current source configuration: 3 coils are necessary.

ANSWER 44. Soviet syndrome related to high electric field exposure. "Jet lag" and other symptoms. Countermeasures adopted by the Soviets: limited hours of exposure.

ANSWER 45. There is 1000 between 1 W and 1 mW. $10 \log 1000 = 30 \text{ dB}$.

ANSWER 46. Difference between successive readings is 10.5 dB = $10 \log (\text{Ratio})$. Ratio = 11.22. $0.01 \text{ mW/cm}^2 \times 11.22 = 0.11 \text{ mW/cm}^2$.

ANSWER 47. Broadband instruments used in the far field. 2 of the list below:

Usable frequency range [small dipoles, frequency compensation]. Directional response [2 or 3 orthogonal transducers]. Field perturbation [resistive leads]. Dynamic range [use instrument with sensitivity compatible with situation]. Sensitivity to ambient temperature [reference junction in the probe itself]. Insensitivity to infrared [shield material].

ANSWER 48. No facial burns in acute carcinogenesis is suspect since doses known to induce cataract in a short period of time would also burn the skin considerably.

ANSWER 49. Surface of half sphere: $r = 200 \text{ cm}$, $4\pi r^2/2 = 251327.41 \text{ cm}^2$. Power density: $90 \text{ W}/251327.41 = 0.36 \text{ mW/cm}^2$. Occupational limit at that frequency is 1 mW/cm^2 . Therefore, exposure is acceptable.

ANSWER 50. By changing the frequency to 1.5 GHz, a gain of 5 is made [standard]. Power is increased, resulting in a "gain" of 0.66. Doubling the distance results in a gain of 4. All factors: $5 \times 0.66 \times 4 = 13.2$ reduction. Reduction necessary was 10. Yes, situation is acceptable.

ANSWER 51. Technician worried about E-field determination in the far field. In the far field, E and B are bound by the impedance of free space, $377 \text{ }\Omega$, so that the power determinations can be made from E or B measurements. A difference due to increased power of the new installation should be accurately detected.

ANSWER 52. The ratio between E and H fields is determined by the local impedance of space, $150 \text{ }\Omega$. The plane wave assumption means using a space impedance of $377 \text{ }\Omega$, therefore

$PDL = 0.2 \text{ mW/cm}^2 = E^2/377$. $E = \sqrt{(0.2 \text{ mW/cm}^2 \times 377)} = 27.5 \text{ V/m}$. Since $E/H = 377$, $H = E/377 = 0.07 \text{ A/m} = 0.09 \mu\text{T}$.

ANSWER 53. $PDL = 50,000 \text{ W}/4\pi \cdot (50,000 \text{ m})^2 = 1.59 \times 10^{-6} \text{ W/m}^2$. $V = \sqrt{PDL \times Z} = 0.0245 \text{ V/m}$. $V_{\text{crest}} = 0.035 \text{ V/m}$. $H_{\text{crest}} = V_{\text{crest}}/377 = 9.2 \times 10^{-5} \text{ A/m} = 1.16 \times 10^{-4} \mu\text{T}$.

ANSWER 54. The duty cycle is the proportion of the time that a device is fully on. In this case, it is on for 1 millionth of a second 1000 times per second: $10^{-6} \times 10^3 = 10^{-3}$. Since the radar is on only 1/1000 of the time, the crest power is $1000 \times 20 \text{ W} = 20,000 \text{ W}$.

ANSWER 55. $SAR = (\sigma_0 + \omega \epsilon_0 \epsilon_1) |E_i|^2 / 2\delta$. σ_0 , the resistive conductivity, is dominant at low frequencies, while $(\omega \epsilon_0 \epsilon_1)$, the dipole polarization loss, is dominant at high frequencies.

ANSWER 56. Maximum = 100 mV/m. RMS = $0.1/\sqrt{2} \text{ V/m}$. $PDL = V^2/Z = (0.0707)^2/377 = 13.3 \times 10^{-6} \text{ W/m}^2 = 1.33 \times 10^{-6} \text{ mW/cm}^2$. $H_{\text{max}} = E_{\text{max}}/377 = 2.65 \times 10^{-4} \text{ A/m} = 3.33 \times 10^{-4} \mu\text{T}$.

ANSWER 57. Canadian dielectric heater survey. The sewing machine type represents the greatest radio-frequency hazard.

ANSWER 58. Occupational limit at 2.54 GHz is 5 mW/cm^2 . Duty cycle factors only as 6 (integration time), exposure is therefore 30 mW/cm or 300 W/m^2 . $E^2 = Z \times PDL = 377 \times 300 \text{ W/m}^2$. $E = 336 \text{ V/m}$.

5.10. Glossary

3-phase: 3 electrical conductors bearing alternating currents that are out of synchrony by 120° with respect to one another

Base-station: stationary element of a communications system involving mobiles or specifically mobile handsets that is hard-wired to a network

Breaker: electrical interruption device, particularly for large powers

Broadcasting: action of distributing information using EM radiation as a carrier

Calcium efflux: ionized calcium exuded from cells, presumably in connection with internal changes in calcium metabolism inside the cell

Capacitance: electrical property which allows the storing of electrical energy as electric field flux density. A capacitance is embodied as a pair of large conductive plates. It advances the flow of current vs voltage in an ac circuit.

Cataract: opacification of the eye's lens due to physical or chemical assault

Cellular phone: telephone not tied to a hard-wired connection, but linked by radio-waves using a set of coordinated base-stations that allow to user to roam across large distances

Childhood leukemia: leukemia occurring in childhood

Connexons: small pores across two cell membranes which allow cells to pass currents and ions across them

Coulomb Force: the basic force of attraction or repulsion between like or different electrical charges

Critical Ignition Energy: the minimum amount of energy required to trigger the spontaneous combustion or explosion of an air-fuel mixture

Current: number of electrons flowing along an electrical conductor

Cyclotron Resonance: a vision of an interaction between fields and ions in the body which assumes a role for the periodic reinforcement of small forces

Defibrillation: returning the muscle of the heart to an anatomically synchronized contraction sequence

Diathermy: the application of RF or MW radiation to the body for therapeutic gain, for example in oncology

Dielectric Constant: quantification of a property of materials which allows them to counteract an externally applied electric field using their own polarization

Dielectric heater: a device using EM waves designed to heat materials, usually in depth

Dielectric Relaxation: the response of a polarizable material to the sudden application of an external field

Dipole: two oppositely charged and mechanically linked bodies considered as a pair

Dissipation Factor: the ratio between the measured resistance and reactance of a given material

Dosimeters: small portable electronic instruments designed to measure EM exposures over time

Electric Field: pattern of Coulomb force

Electro-Therapy: use of electrical action in medical treatment

Electrocardiogram: the electrical signals caused by the contraction of the heart muscle, specifically as received at the surface of the chest

Electroconvulsive Therapy: deliberately causing a neurologic seizure using external current stimulation

EM induction: producing the movement of electrical charges by remote action, specifically using magnetic fields as an energy source

EM protein: cellular protein synthesized specifically as a result of EM exposures

EM Waves: EM energy spontaneously traveling across space

Electroporation: application of an electrical potential to a cell membrane with the goal of inducing membrane permeability

Electropuncture: application of an electrical potential to a cell membrane with the goal of inducing membrane puncture

Electrostatic induction: producing the movement of electrical charges by remote action, specifically using electric fields as an energy source

ELF or Extra-Low Frequency: the frequency domain from 3 to 300 Hz

EMC or EM Compatibility: techniques involved in insuring that electronic equipments of various kinds will not interfere with one another when used at the same time in some proximity

Energy: basic physical variable viewed as the application of a force over a distance or as power applied over a given time; equivalent to amount of heat and to mass

Far field: region in which the inverse-square-law applies for fields of various types

Fibrillation: uncoordinated contraction of the heart muscle which leads to loss of its function as a pump

Field Coherence: the regular, unperturbed periodicity of an electric or magnetic field

Fuse: protection device which melts under the action of an excessive current to protect equipment

GFCI or Ground Fault Circuit Interrupter: a measuring device which adds electrical currents flowing through a circuit and takes action if the difference between them exceeds a value that could be lethal to a human

Ground: electrical connection that serves as a zero reference; expected to be the potential of human beings under safe conditions

Hyperthermia (oncological): method of destroying cancer cells based on their specific intolerance of heat

Impedance: opposition to current passage generalized to take into account current magnitude reductions as well as phase shifts in alternating currents

Impedance of Free Space: the ratio between E and B fields in a freely propagating EM wave

Inductance: electrical property which allows the storing of electrical energy as magnetic flux density. An inductance is embodied as a coil of wire. It retards the flow of current vs voltage in an ac circuit.

Induction heater: heating device based on a magnetic field inducing a current into a conductive material

Insulation Transformer: transformer placed into a circuit for the purpose of inhibiting current passage between the pairs of wires at the primary and those at the secondary

Li-Fi: data transmission using visible light.

Live line stick: insulating stick used to perform mechanical or measurement actions on live wires, usually at high voltages

Lorentz Force: sum of the forces originating from electric and magnetic fields

Magnetic Field: pattern of Coulomb forces acting on a moving charge specifically due to the charge's motion.

Magnetotactic bacteria: bacteria capable of using the static magnetic field of the earth for orientation because they contain magnetic particles

Maxwell's Equations: four equations which describe completely the behavior of EM fields

Melatonin: a neuro-hormone involved in initiation of sleep and in free-radical scavenging

Membrane Potentials: voltages applied across cell membranes either from metabolism or from external fields

Mobile: the unrestricted element in a system which allows free roaming of users as communications are maintained by EM waves

Modulation: changes applied to sinusoidal EM waves in order to allow them to carry useable information

Monopole: the simplest radiating antenna, in the form of a whip (such as installed on many cars)

MPR Standard: Swedish limit of magnetic and electric fields allowed to emanate from Video Display Units

Narrow band instrument: measuring EM instruments which select a narrow part of the spectrum for measurement

Near field: region between the source of an EM field and the limit beyond which the inverse-square-law applies for fields of various types

NMR or Nuclear Magnetic Resonance: a technique of detection and imaging which uses the resonance between the magnetic fields of atoms in the body and that of an applied electro-magnetic field to produce non-destructive pictures of living tissues

Non-thermal effect: effect of an EM field on living tissues which is not due to a temperature increase

Ohm's Law: definition of the relation between magnitude of current and voltage within a conductor

Pacemakers: electronic devices implanted in arrhythmic patients in order to stabilize heartbeat

Padlocking: safety measure which protects subjects from contact with electrical potentials by preventing the activation of electrical sources using mechanical locks

Parabolic antenna: reflector used as a means to concentrate EM radiation into a beam

PEMFs or Pulsed EM Fields: EM fields with their energy concentrated over a small interval of time (low duty cycle) and including high frequencies

Pineal bio-rhythm: the spontaneous cyclic activity of the pineal gland, particularly in its liberation of melatonin

Power: energy expended per unit time

Radar: device for the detection and localization of objects using the reflection of radio-waves

Resistance: ability of a material to pass limited current under an applied voltage

Risk assessment: assembly of methods used to gauge the risks to health of various environmental factors

Root-mean-square: way of specifying the intensity of a sinusoidal wave using successively the squaring, averaging and rooting of signal amplitude

Rubber glove: gloves completely covered with rubber to provide safe handling opportunities for workers needing to handle energized wires or structures

SAR or Specific Absorption Rate: amount of energy injected into a material per unit of weight by an EM field

Shock Threshold: limit current value at which a physiological event is likely to occur as a result of the passage of electrical current

Sine-wave: the particular time-course of a signal resulting from simple harmonic motion

Special Relativity: part of the theory of relativity dealing with the contraction of time according to relative speed

Step Voltage: the voltage applied across the two feet of a subject under an electrical accident scenario

Survey meters: electronic instruments used to measure the presence of EM fields and requiring operation

T-wave: part of the electrocardiogram corresponding to recovery from excitation in the ventricles

Thermal effect: effect of EM radiation associated with a temperature rise

Thermal Noise: irregularity in a physical variable due to the random kinetic motion of particles at a given temperature

Touch Voltage: the voltage applied between hand and feet of a subject in an electrical accident scenario

VDU or Video Display Unit: evacuated lamp with a flat front surface used to display images for human observers, usually associated with computers

Voltage: "pressure" applied to electrical charges

Wide-band instrument: measuring EM instruments which seeks to include a wide part of the spectrum for measurement
Window Effects: biological effects which occur only within a range of intensities or frequencies